

# TECHNICAL SUMMARY SPL

F. Gerigk, CERN

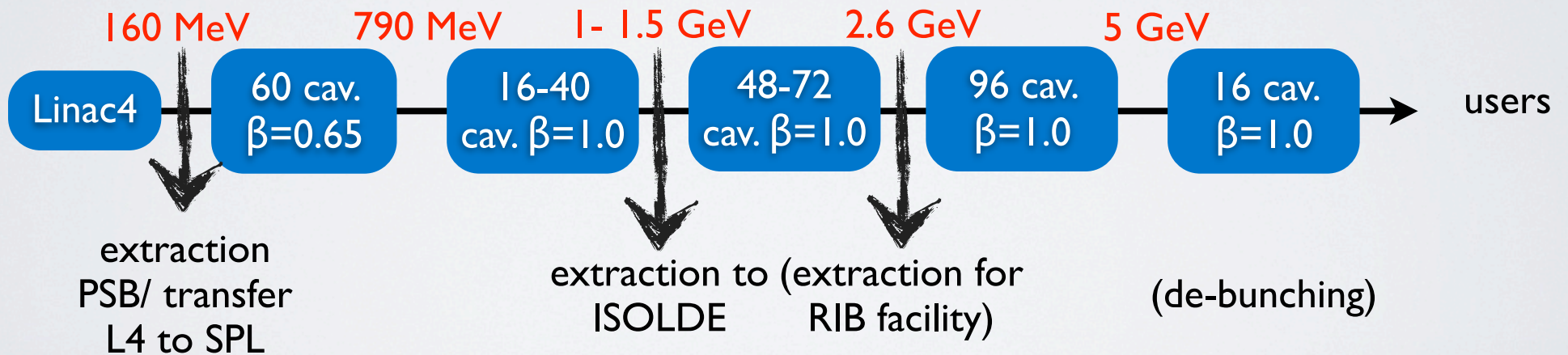

# OVERVIEW

- common interests with SNS, JPARC, Project X, Myrrha,
- simulation work & technical progress on the SPL side,
- preparation of cavity/cryo-module tests at CERN,

# INTRODUCTION

SNS

ProjectX

SPL

ESS

JPARC

Myrrha

# SNS, EXPERIENCE & UPGRADE

- highest down times due to: ion source, modulators (big improvements already made), RF system
- cavities can be operated individually at 17-20 MeV/m, but not collectively,
- R&D on improved fabrication of SC cavities: EP (reduces X-ray level), better welding procedures, plasma cleaning

collaboration possibilities on:

H- ion source

klystron  
modulators

low-beta  
cavities &  
cryo-modules

# PROJECT X

## collaboration possibilities on:

- 1 mA average current with a chopped substructure (up to 10 mA)
- R&D on low-beta cavities (650 MHz) and cryo-modules,
- goal of 15 MeV/m at  $Q=1.5 \times 10^{10}$  based on  $Q$  slope,
- beam tests of cryo-modules are foreseen.

broad band  
chopping

low-beta  
cavities &  
cryo-modules

# MYRRHA

- XT-ADS demo, 600 MeV, 2.5-4 mA CW proton beam, operational in 2023.
- main focus on reliability: conservative gradients, independently phased cavities, redundancy, fault recovery scenarios,
- CH structures (17 MeV), spoke cavities (90 MeV), elliptical 704 MHz (600 MeV)

RFQ  
development

reliability/fault  
recovery

352/704 MHz  
RF system

# JPARC

- in full operation, 30 mA peak current in linac, goal: 50 mA, R&D on Caesium fed RF source R&D started (SNS),
- klystrons have worked for 16000+ hours without any degradation/problems,
- LLRF control of cavities (FB & FF):  $\pm 0.15\%$  and  $\pm 0.15$  deg have been achieved,
- highest downtimes were caused by RFQ, the problem is solved (oil free pumps), now PS kickers dominate the statistics, back-up RFQ under construction,
- 200-400 MeV ACS under construction, 9-cell 972 MHz cavities (2 K) were tested and activity will pick up with power upgrade.

H- ion source

RFQs

low-beta  
cavities & cryo-  
modules

# RF SYSTEMS

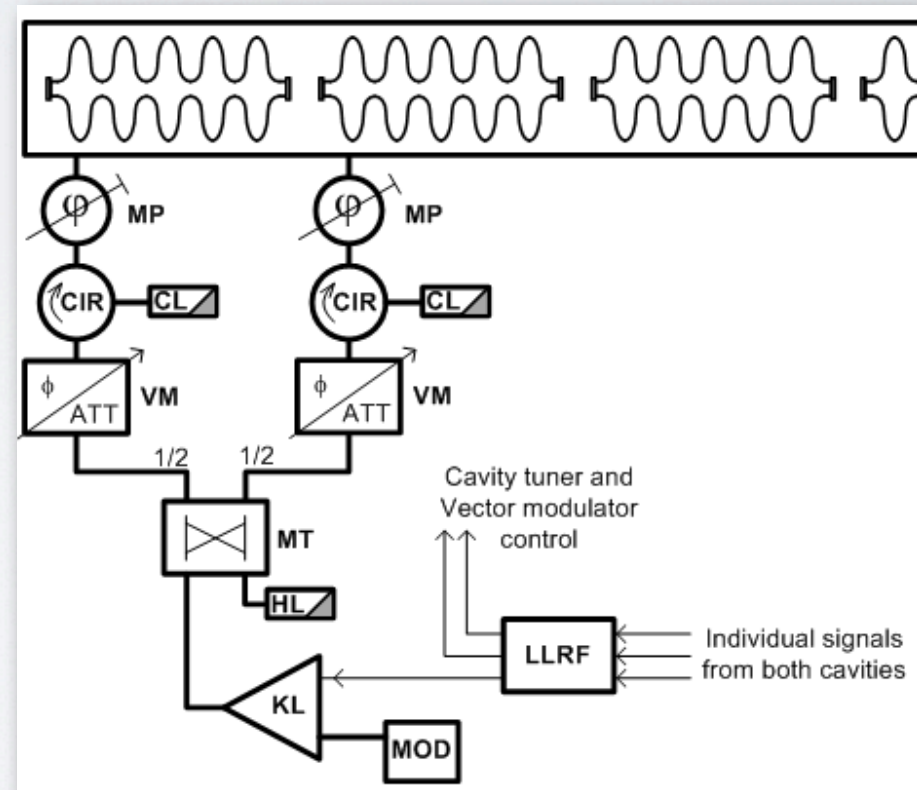



# RF SYSTEM R&D:

- **power splitting:** from one klystron to 2 cavities, (use fixed 3-stub tuners instead of vector modulators), IOTs or solid state (<350 kW) for low beta section (one per cavity) need prototyping,
- planning and preparation of **RF test place** in progress (consolidation with other projects at CERN is done), assembly procedure for cavities must be clarified,
- preparation of low-power tests in **vertical cryostats** started, diagnostics being prepared (T-mapping, second sound, etc),
- list of test places & capabilities in preparation (ESS/SPL),

# KLYSTRON MODULATORS

## 3 possibilities!

- JEMA is working on a ESS/SPL type 60 Hz modulator prototype, to be tested in 2011 at SNS (based on their own HV/HF transformers, dry transformer under study) using a mixture of MARX and HF transformer based approach,
- CERN design effort until 2014/15,
- Scandinova has done a pre-study with ESS specs, ESS is preparing tendering for test stand modulator,

# LLRF

**advance in simulation efforts for cavity testing and operation (beam/no beam conditions):**

- Code with GUI for drive of 1 versus 2 (or more) cavities with one klystron and without vector modulators, models for cavities (w. Lorentz force detuning)/RF transport are implemented, beam current &  $Q_{ex}$  variations, test data from 704 MHz cavity tests at Saclay is incorporated,
- 2-cavity model w/o vector modulator seems feasible with feed-forward and piezo tuning, provided the maximum difference in loaded  $Q$  is  $< 10000$ , first estimates of controls power indicate 20-30 kW p. cavity,
- results now to be checked by beam dynamics,

# SC CAVITIES

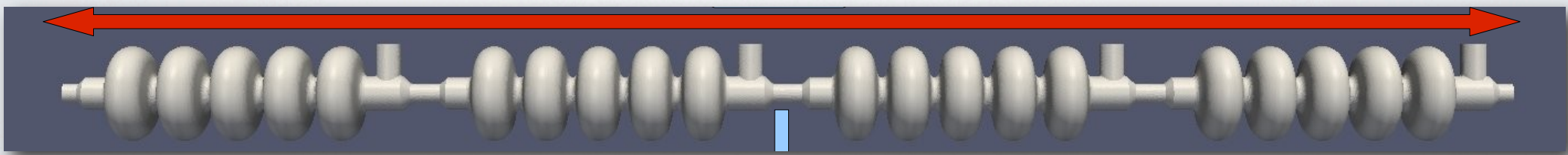
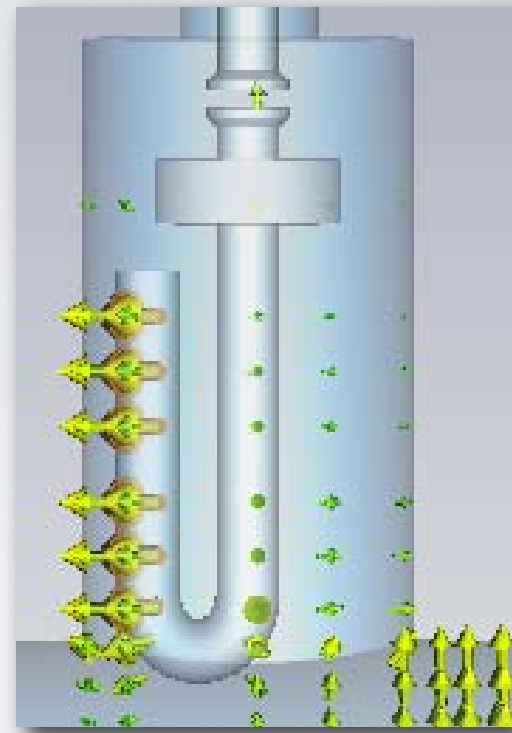

# BETA=1 CAVITY

- **cavity shape** has been optimised and **coupler position** was chosen (CEA),
- **max. pressures** at 2 and 300 K are defined (2/1.5 bars),
- traditional “hook-type” **HOM couplers** are foreseen, bellows do not couple to HOMs (and damp) sufficiently, need for notch filter and foresee dismountable coupler,
- **inter-cavity distance** set to  $2 \times \lambda/2$  (based on a “weak” argument: wave-guide splitting network), can be re-considered,
- **cavity geometry** and location of couplers fixed,
- **Nb thickness** defined (min. 2.5 mm for starting sheet thickness 3.6 mm), spinning/EP/

- Preparation of EP station is progressing (simulation work and installation of hardware),
- **mechanical optimisation (CEA)**: increased stiffness of He tank, optimised of tuner design (easier assembly, fits for low & high-beta cavities, integration with HOM coupler), improvements on Lorentz Force Detuning Compensation,
- CEA cavities are expected by end of 2011,
- **mechanical optimisation on cavity (CERN)**: half cells by spinning then EBW, complete construction process is defined using the DESY recipe, spinning tests done Nb and Cu to define final geometry, stress simulations show that we always stay below the max. allowable limits, mechanical resonances (1st long. at 130 Hz, 1st tr at ~50 Hz but less important),
- Cu cavities by end of 2010, 4 Nb cavities by end of 2011 (in industry), 4 additional cavities by end of 2013 (made at CERN),

# BETA=0.65 CAVITY

- **EM simulations:** design optimisation for field flatness, coupling to power coupler, cell-to-cell coupling, R/Q,
- **Mechanical simulations:** end-cell thickness must be increased to 5 mm (final value), stiffening rings between inner cells,
- **design now adapted to be tested in the 4-cavity  $\beta=1$  cryo-module,** (same end-groups, same interfaces) -> reduced thickness of Nb at end-cells (4 mm),
- planning foresees first test end of 2011 (vertical cryostat).

# HP/HOM COUPLERS

- CEA HP coupler has been qualified at 1.1 MW, 2 ms, 50 Hz,
- CERN pursues its own HP coupler design (2 alternative designs), not adjustable but use 3-stub wave-guide tuner to compensate  $Q_{ex}$  differences, coupler at the bottom, coupler design progresses rapidly (2 types/4 units until mid 2011),
- test of CERN HP couplers at CEA is being prepared,
- HOM coupler design with notch filter under development at Rostock Uni., assessment of coupling to HOMs & fundamental mode rejection versus 20 free mechanical design parameters, new funding now secured by german ministry,



# RF SIMULATIONS

- RHUL is able to simulate (ACE3P) a complete string of 4 cavities and to identify all 4x5 modes of the passband + HOMs, can quantify coupling of fundamental + HOMs for different inter-cavity geometries,
- HOM spectra with respect to different end-groups, now building CEA design but needs to be re-considered for next design iteration,
- recommended  $Q_{ex}$   $10^7$  w/o machine lines,  $10^5$  in presence of machine lines, but to reduce HOM power into loads to 100 W we need  $10^4$ , further work needed before making decisions on “final” value,
- damping of HOMs via bellows works well above 1800 MHz, need to work out heat load into 2 K system in worst case,
- design of magnetic shielding progresses (permeability, thickness, geometry),

# RF SIMULATIONS

- BNL: propagate HOMs out of the cavity and use 4 HOM couplers on each side (new more robust filter design), high extracted power of  $\sim 1$  kW per coupler, new design with higher  $E_{\text{peak}}/E_{\text{acc}}$  field but lower peak magn. field and improved R/Q and G,
- TU Darmstadt: bringing together eigenmode simulations and Fourier transformations of transmission spectrum, new meshing (symmetric around axis) technique to improve field resolution along x and y direction and use curved mesh cells for better adaptation to elliptical cell shape.

# CRYO-MODULES FOR ELLIPTICAL CAVITIES

## Some theory concerning HeII

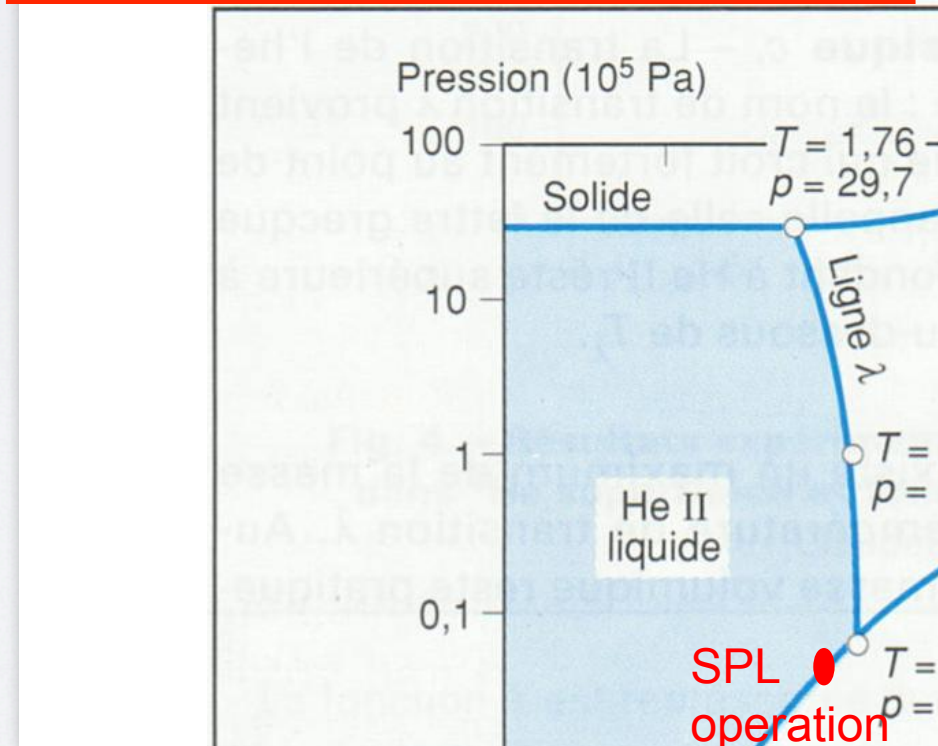

- ESS cryo-segmentation study comes to the same results as CERN, both projects need further work on static loads,
- CERN is preparing a high-power test of a 4-cavity “short” cryo-module, to be used for proof-of-concept of aspects of the “final” machine design, in close collaboration with ESS/CNRS/CEA,
- power coupler at the bottom, since HOM coupler has to be on top,
- new cavity support system (via power couplers) is under study including the required inter-cavity guiding systems,
- alignment budget is defined, simulation work on coupler-supported cavities in progress, different cryo-vessels under study, preliminary cryogenic supply scheme is defined,
- Ti He tanks for 4-cavity module, stainless steel tank will be designed for 2nd module,

- double walled tube for main coupler to reduce heat load at 2 K (21 W → 0.1 W), semi-analytical simulation model has been validated with LHC geometry, double wall can even support full cantilever situation in case the cavity “sits” only on the power coupler,
- optimisation of interface to cryogenic lines by considering max. heat flux through given channel, important to consider all possible operational scenarios!!
- planning and construction plans of CNRS/CEA have been adapted to the needs of the 4-cavity cryo-module,
- preparations for frequent assembly/disassembly,
- design review planned for 3d quarter 2011,

# BEAM DYNAMICS & DUMP

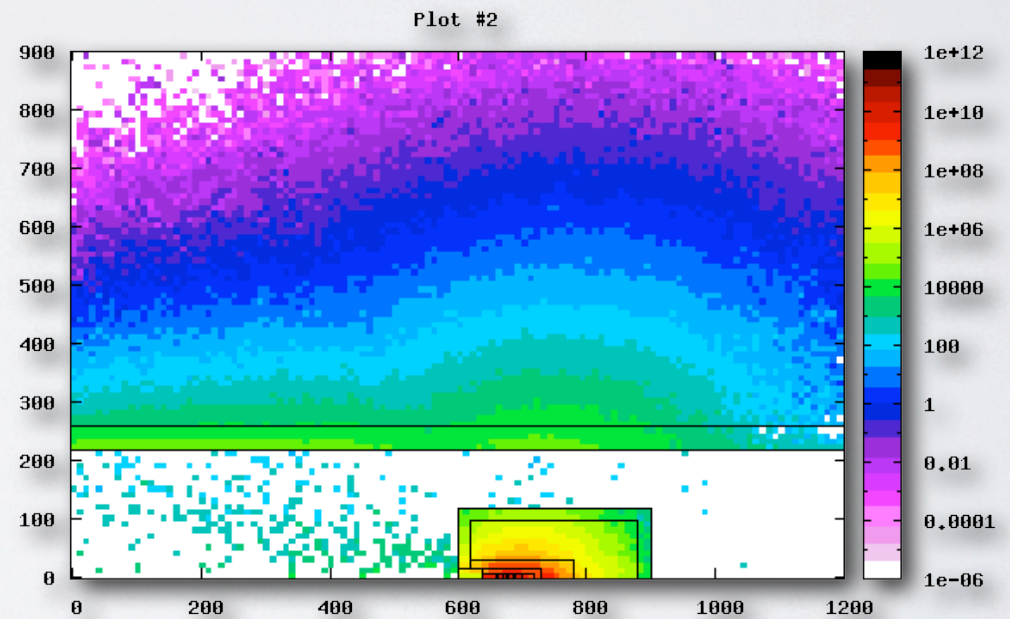

- defined **baseline layout** with extractions at 1.4 and 2.5 GeV, and beam transport Linac4/SPL, FD focusing to allow warm quads,
- **FD** requires higher quadrupole fields which increases H<sup>-</sup> stripping probability by 6 orders of magnitude (→ min. length), possibility to go to **FODO** after 2.5 GeV extraction, multipoles of steerers can induce sextupole resonances,
- **To do**: RF tolerances (HOM, LLRF) need further iterations, collimation system, finalise diagnostics needs,
- **dump** parameters are defined (commissioning and operation) and a dump design from FNAL has been used as basis for the SPL dump,
- baseline design has been studied, it was shown that **public areas** above the dump are **safe** for access,
- **activation of surrounding areas** is studied: access limits after certain cool-down times,
- **earth and ground water activation** has been studied (don't source drinking water next to the dump, water ingress ok),