

# New Experiments with Antiprotons

Daniel M. Kaplan

for the Fermilab pbar Collaboration



<http://capp.iit.edu/hep/pbar/>

## Hyperon CPV & Rare Decays

- Example Feynman diagrams (Standard Model):

tree:

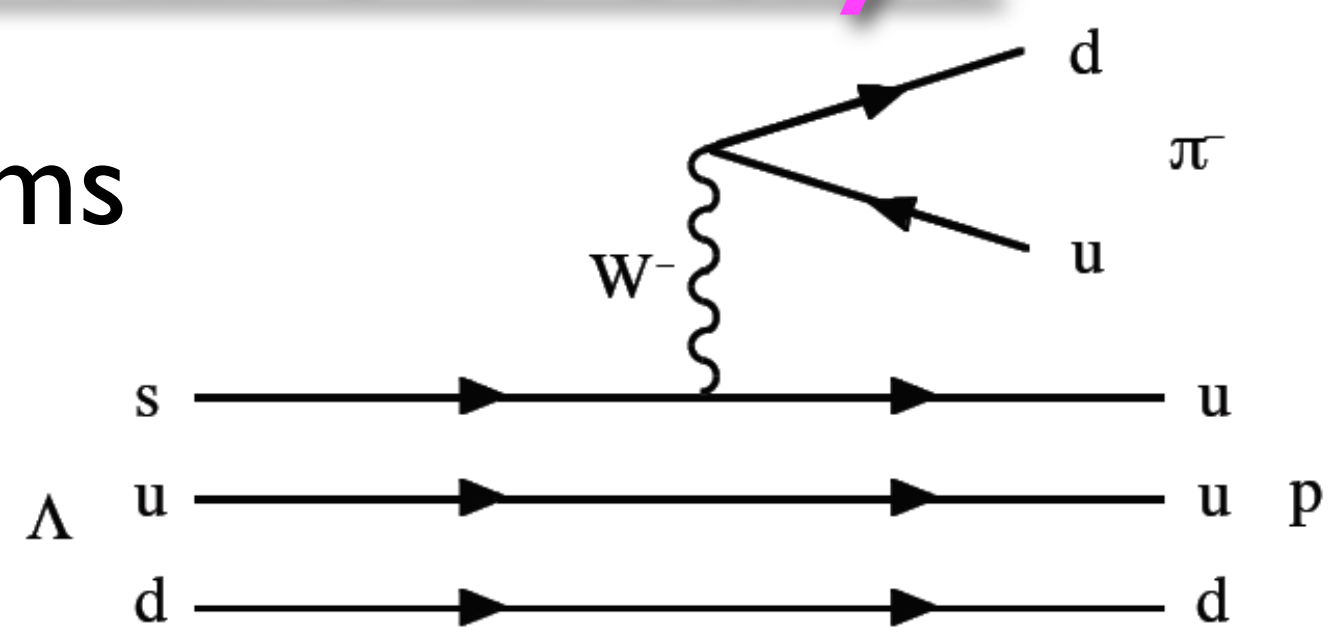

penguin:

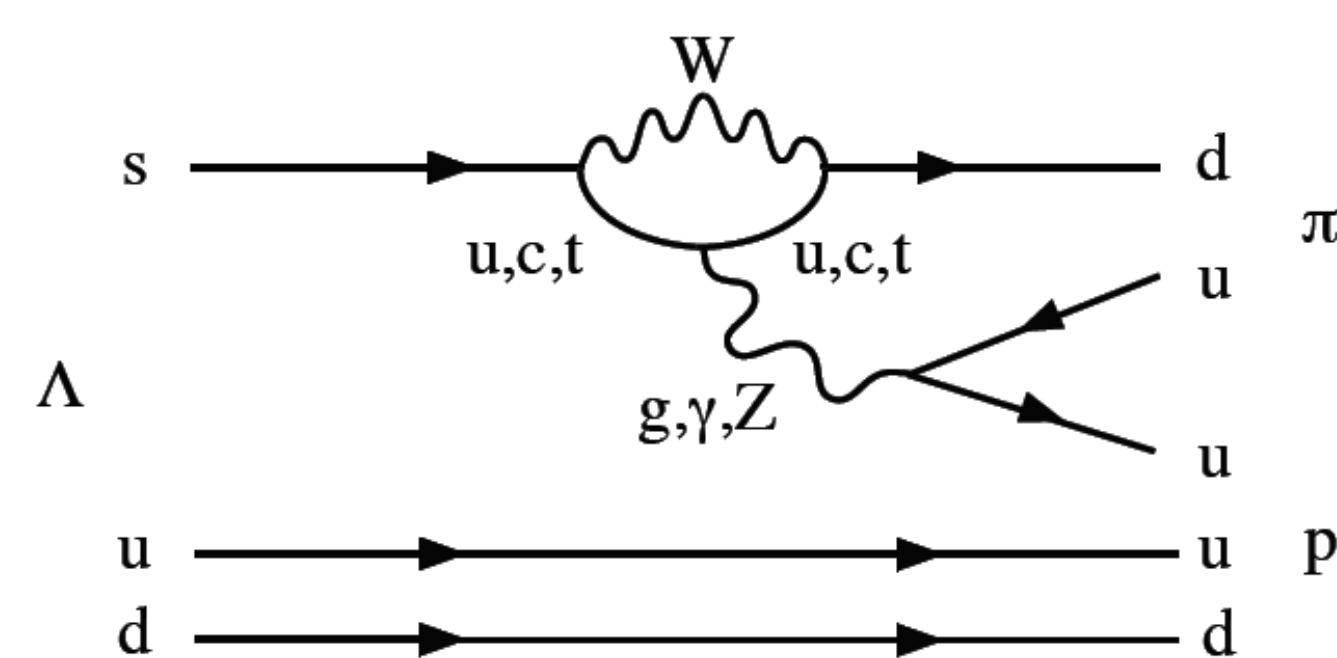

- New physics can contribute too!

Asymm.	Mode	SM	NP
$A_\Lambda$	$\Lambda \rightarrow p\pi$	$\lesssim 10^{-5}$	$\lesssim 6 \times 10^{-4}$
$A_{\Xi\Lambda}$	$\Xi^\mp \rightarrow \Lambda\pi, \Lambda \rightarrow p\pi$	$\lesssim 0.5 \times 10^{-4}$	$\leq 1.9 \times 10^{-3}$
$A_{\Omega\Lambda}$	$\Omega \rightarrow \Lambda K, \Lambda \rightarrow p\pi$	$\leq 4 \times 10^{-5}$	$\leq 8 \times 10^{-3}$
$\Delta_{\Xi\pi}$	$\Omega \rightarrow \Xi^0\pi$	$2 \times 10^{-5}$	$\leq 2 \times 10^{-4}$ *
$\Delta_{\Lambda K}$	$\Omega \rightarrow \Lambda K$	$\leq 1 \times 10^{-5}$	$\leq 1 \times 10^{-3}$

- Rare decays:

- HyperCP observed  
 $3 \Sigma^+ \rightarrow p\mu^+\mu^-$  events
- Consistent with new low-mass  
 $\chi^0 \rightarrow \mu^+\mu^-$

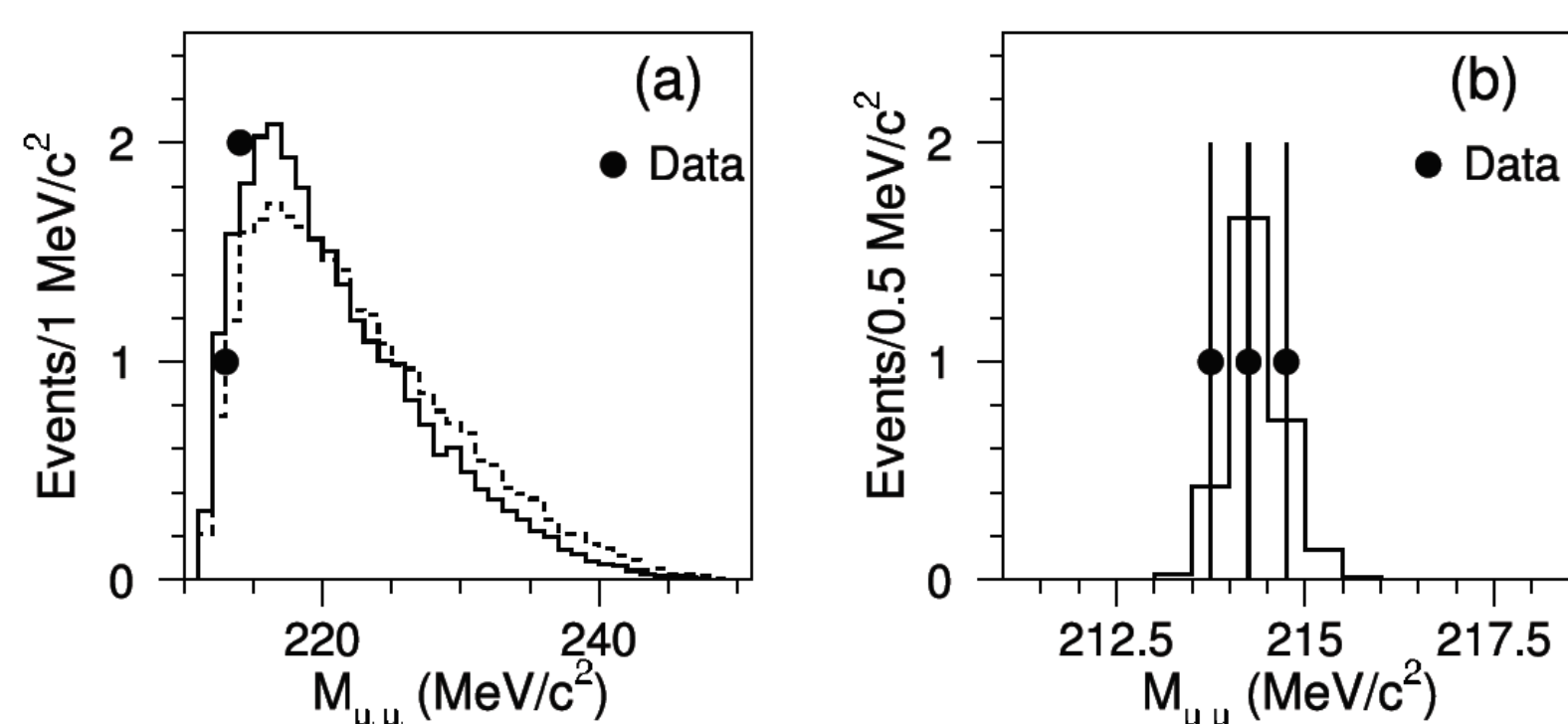

- Aim to start with  $\bar{p}p \rightarrow \Omega^- \bar{\Omega}^+$
- Sensitive to  $B \sim 10^{-6}$ , CP asymm  $\sim 10^{-4}$
- Probe both parity-conserving and violating interactions  $\Rightarrow$  complementary to K & B studies

## Antihydrogen Measurements

- $\bar{H}$ -in-flight CPT test feasible:

REVIEW D

VOLUME 57, NUMBER 11

### Measuring the antihydrogen Lamb shift with a relativistic antihydrogen beam

G. Blanford, K. Gollwitzer, M. Mandelkern, J. Schultz, G. Takei, and G. Zioulas  
University of California at Irvine, Irvine, California 92717

D. C. Christian  
Fermilab, Batavia, Illinois 60510

C. T. Munger  
Stanford Linear Accelerator Center, Stanford University, Stanford, California 94309  
(Received 18 December 1997; published 4 May 1998)

We propose an experiment to measure the Lamb shift and fine structure (the intervals  $2s_{1/2} - 2p_{1/2}$  and  $2p_{1/2} - 2p_{3/2}$ ) in antihydrogen. A sample of 10 000 antihydrogen atoms at a momentum of 8.85 GeV/c suffices to measure the Lamb shift to 5% and the fine structure to 1%. Atomic collisions excite antihydrogen atoms to states with  $n=2$ ; field ionization in a Lorentz-transformed laboratory magnetic field then prepares a particular  $n=2$  state, and is used again to analyze that state after it is allowed to oscillate in a region of zero field. This experiment is feasible at Fermilab. [S0556-2821(98)04711-0]

- Interferometric  $\bar{H}$  gravity test:  $\nexists$  direct limit

- simple solution to missing antimatter & dark energy:  
 $\rightarrow$  could matter & antimatter repel gravitationally?
- more generally, quantum gravity can have scalar & vector terms as well as tensor  
 $\Rightarrow \bar{g}/g = 1 \pm \epsilon$
- measurement feasible with proven technology (trapping, atomic interferometer)
- goal: determine  $\epsilon$  first to  $10^{-4}$  (gravings), then  $10^{-9}$  (lasers)

- ▶ First test of Equivalence Principle for antimatter

## Abstract

Fermilab operates the world's most intense source of antiprotons. Experiments have been proposed that can use those antiprotons either parasitically during Tevatron Collider running or after the Tevatron Collider finishes in about 2011. We summarize the physics goals and potential of the proposed experiments.

## Proposed Exp'tal Approaches

- FNAL Antiproton Source is world's most intense – even after FAIR@Darmstadt turns on (~2018)
- Opportunity for small, simple experiments soon after Tevatron finishes
- Medium-Energy experiment: “upgraded E835” with magnetic spectrometry:

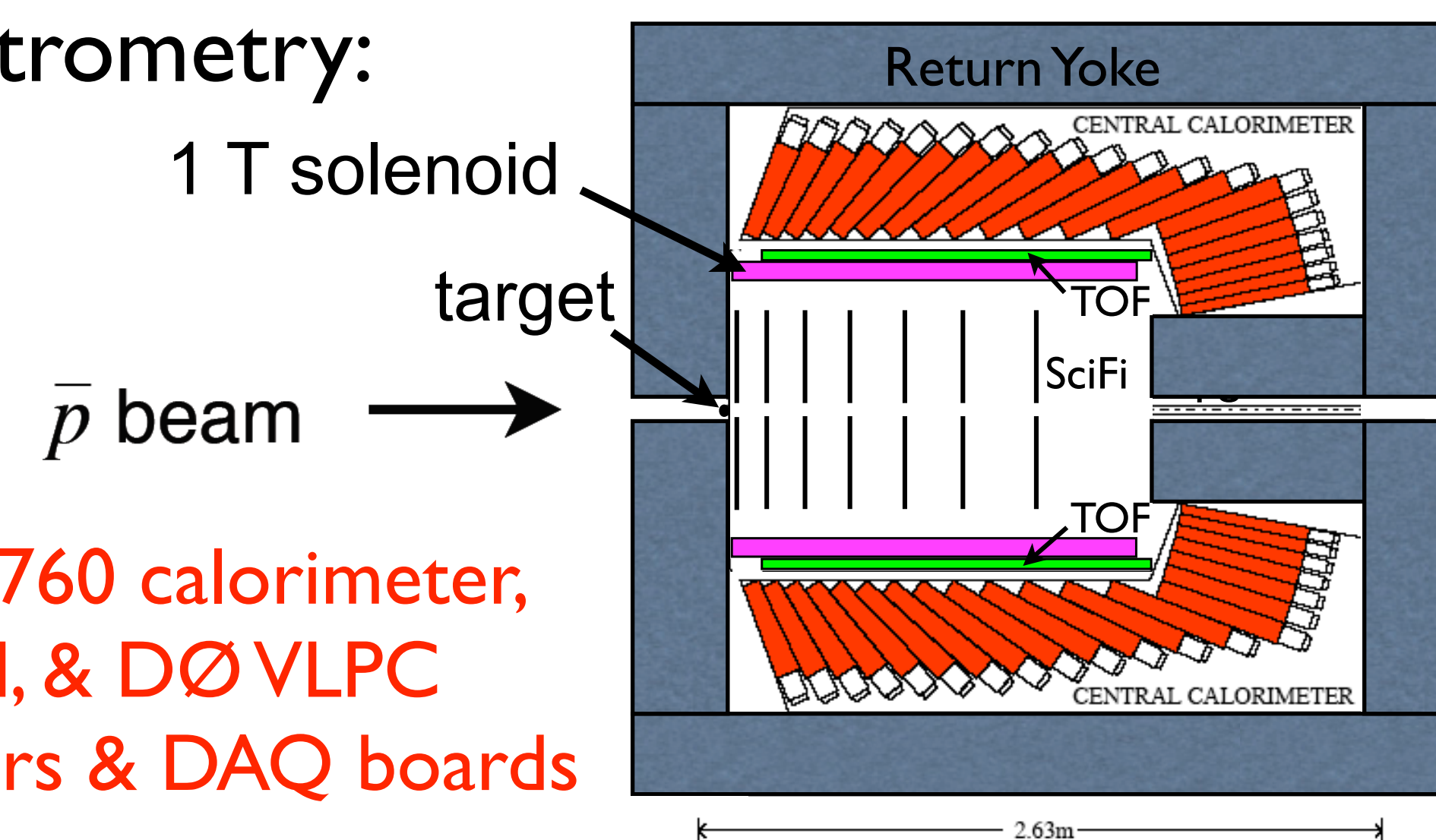

- ▶ use existing E760 calorimeter, BESS solenoid, & DØ VLPC photodetectors & DAQ boards

- $\mathcal{L} \sim 10^{32}$  feasible  $\Rightarrow \sim 10^8 \bar{p}p \rightarrow \Omega^- \bar{\Omega}^+$  events/year
- Slow- $\bar{H}$  expts: decelerate in MI & degrade into trap
- Possible future upgrade: add small decelerator ring

## Charmonium & XYZ States

- $\bar{p}p$  can directly form states of all non-exotic  $J^{PC}$
- $\bar{p}p$  capable of precision mass & width meas<sup>ts</sup>, e.g.:

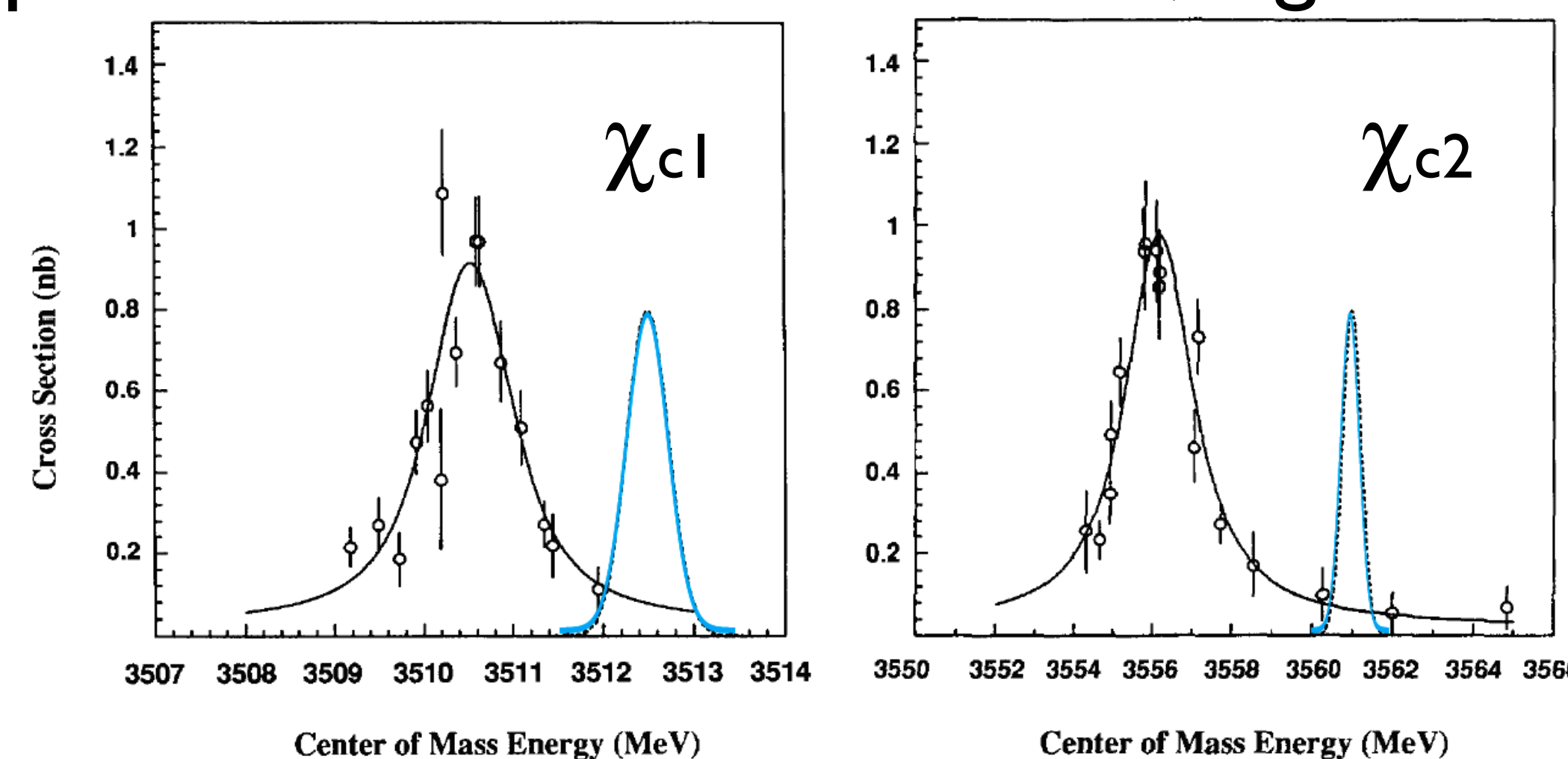

FNAL E760  
 $\sigma_m(\text{beam}) = 0.5 \text{ MeV}$

- Directly study singlet states:  $\eta_c, h_c, \eta_c(2S)$  & other non- $1^-$  states (e.g.,  $\chi_c$ 's)

### XYZ States

- ▶ Are XYZ states charmonium or hybrids or...?

State	$J^{PC}$	Mass	Decay Modes
X(3872)	$1^{++}$	$3871.2 \pm 0.5$	$J/\psi \pi^+ \pi^-, J/\psi \pi^+ \pi^- \pi^0, J/\psi \gamma$
X(3872)	???	$3875.5 \pm 0.7$	$D^0 \bar{D}^0 \pi^0$
Z(3930)	$2^{++}$	$3929 \pm 6$	$D^0 \bar{D}^0, D^+ D^-$
Y(3940)	$?^{++}$	$3943 \pm 17$	$J/\psi \omega$
X(3940)	$?^{++}$	$3942 \pm 9$	$D \bar{D}^*$
Y(4008)	$1^-$	$4008 \pm 65$	$J/\psi \pi^+ \pi^-$
X(4160)	$?^{++}$	$4156 \pm 27$	$D^* \bar{D}^*$
Y(4260)	$1^-$	4259, 4284, 4247	$J/\psi \pi^+ \pi^-, J/\psi \pi^0 \pi^0, J/\psi K^+ K^-$
Y(4350)	$1^-$	4324, 4361	$\psi(2S) \pi^+ \pi^-$
Z <sup>+</sup> (4430)	??	$4433 \pm 5$	$\psi(2S) \pi^+$
Y(4620)	$1^-$	$4464 \pm 13$	$\psi(2S) \pi^+ \pi^-$

## Charm CPV

- $\sigma(\bar{p}p \rightarrow D^* \bar{D}) \sim 1 \mu\text{b}$   
 $\Rightarrow > 10^{10}$  events produced
- charm mixing: new physics?
- ▶ Potential world's-most-sensitive measurement

D\* $\bar{D}$  cross-section estimate (after E. Braaten, Phys. Rev. D 77, 034019 (2008))

