



S-Waves & the measurement of β_s in B_s decays

Sheldon Stone

ICHEP, Paris, July 2010



Mystery of Scalar Mesons

- 0^+ nonet is not well understood
- Compare 0^- versus 0^+

Quarks	Pseudoscalar		Scalar	
	Particle	Mass (MeV)	Particle	Mass (MeV)
$1/\sqrt{2}(u\bar{u}+d\bar{d})$	π^0	135	$\sigma ?$	~ 600
$u\bar{d}$	π^+	139	a_0^+	980
$u\bar{s}$	K^+	495	$\kappa^+ ?$	~ 900
$\sim s\bar{s}$	η'	960	f_0	980

- For 0^- nonet, the mass increases by ~ 400 MeV for each s quark. Why isn't this true for the 0^+ nonet?
 - Why aren't the a_0 & the σ degenerate in mass?
- Suggestions that the 0^+ are 4-quark states

S-waves in $D_s \rightarrow \mathcal{K}^+ \mathcal{K}^- \pi^+$ decays

■ Dalitz analyses (also E687)

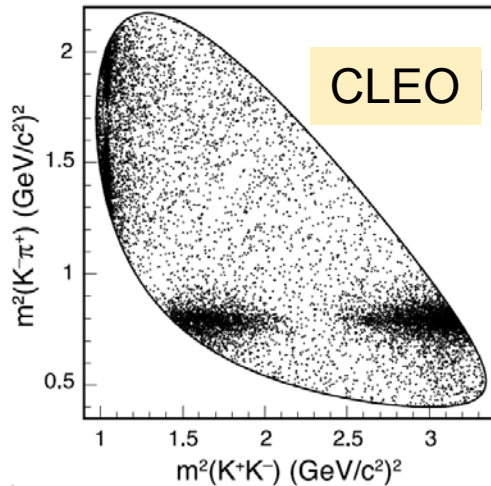

Particle	J^P	Fit Fraction (%) (sums to 130%)
$K^*(892)$	1^-	47.4 ± 1.5
$\phi(1020)$	1^-	42.2 ± 1.6
$f_0(980)$	0^+	28.2 ± 1.9
$f_0(1370)$	0^+	4.3 ± 0.6
$K_0^*(1430)$	0^+	3.9 ± 0.5
$f_0(1710)$	0^+	3.4 ± 0.5

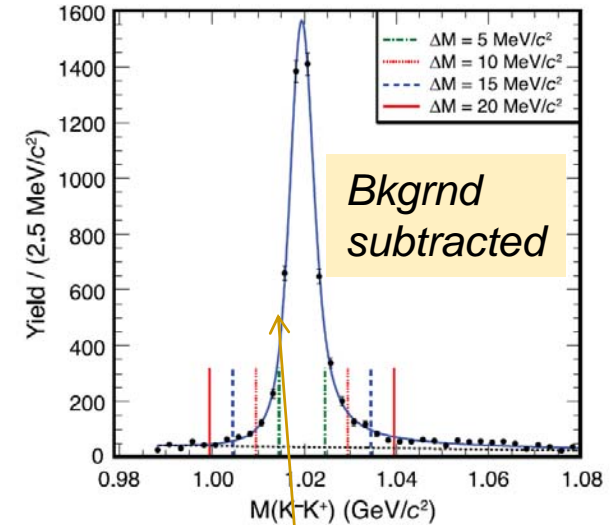

- Fit using a linear S-wave + Breit-Wigner convoluted with Gaussian for the ϕ . Find 6.3% (8.9%) S-wave for ± 10 MeV (± 15 MeV)

S-waves via Interference in semileptonic decays

- $D^+ \rightarrow K^- \pi^+ \mu^+ \nu$: Though $K\pi$ is dominantly K^* , FOCUS observed an interfering S-wave amplitude with a rate fraction of $(2.7 \pm 0.4)\%$ for $0.8 < m(K\pi) < 1.0$ GeV
- $D_s \rightarrow K^+ K^- e^+ \nu$: S-wave fraction of $(0.22^{+0.12}_{-0.08})\%$ for $1.01 < m(K^+ K^-) < 1.3$ GeV (BaBar)

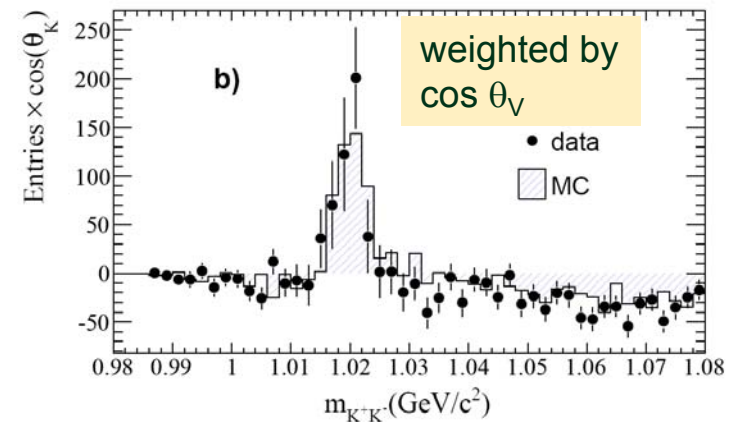
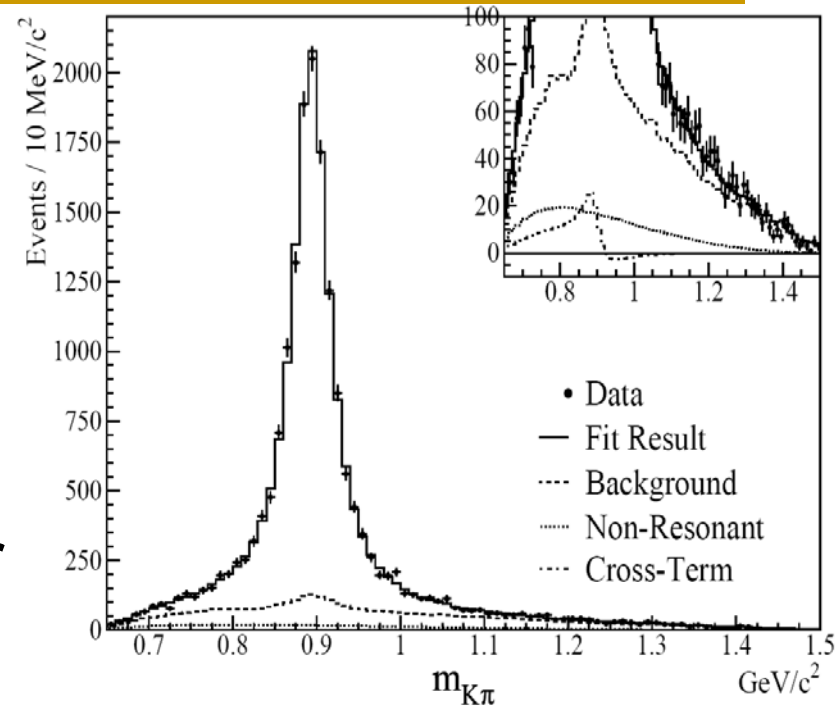

The S-Wave in $B \rightarrow J/\psi \mathcal{K}^*$

- Two Vectors in final states so a transversity analysis is required
- BaBar & Belle measure interference between S & P waves in \mathcal{K}^* decay angle
- The fraction of S-wave intensity is $(7.3 \pm 1.8)\%$ for $0.8 < m(K\pi) < 1.0$ GeV
- BaBar uses this interference to remove ambiguities in the measurement of $\cos(2\beta)$

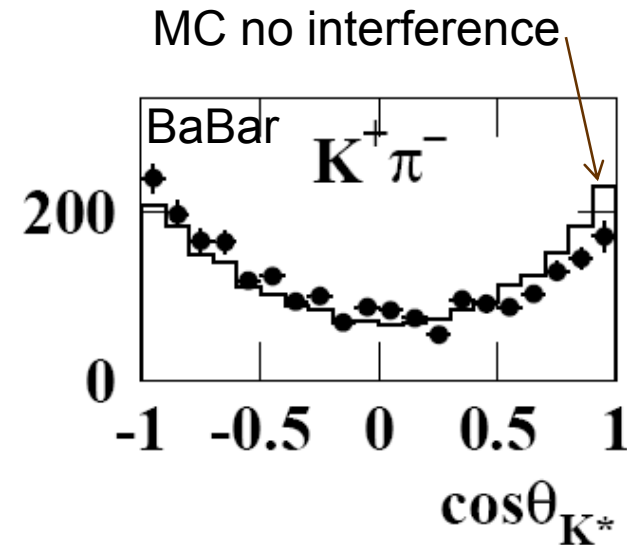
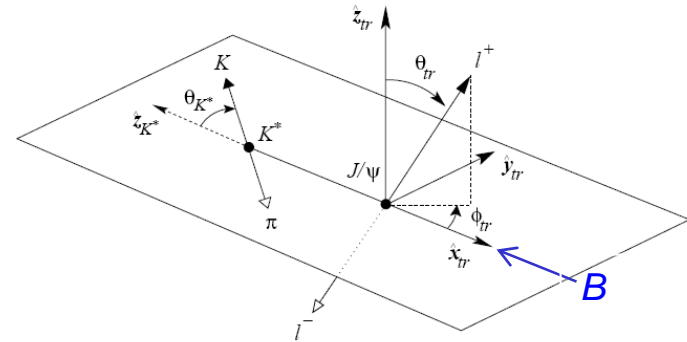

Measuring β_s in B_s Decays

- Thus far $B_s \rightarrow J/\psi \phi$ used exclusively
- $B_s \rightarrow \phi \phi$ suggested, for null measurement, as decay phase cancels mixing phase
- These modes are Vector-Vector final state, so must disentangle CP+ & CP- final states using an angular analysis

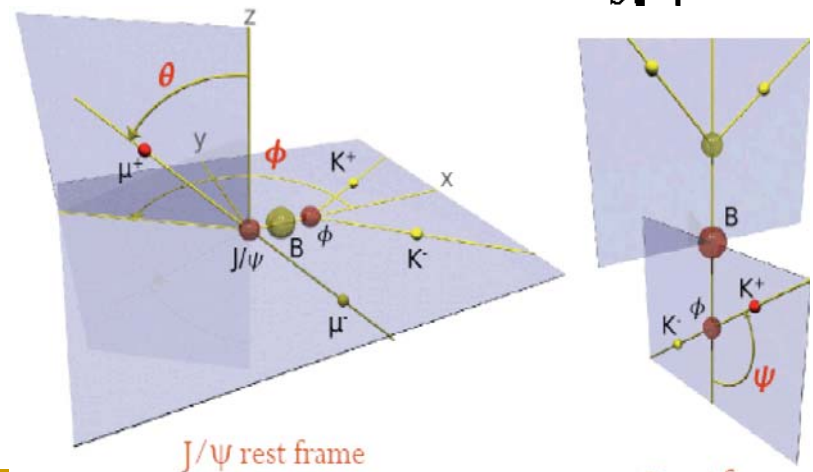
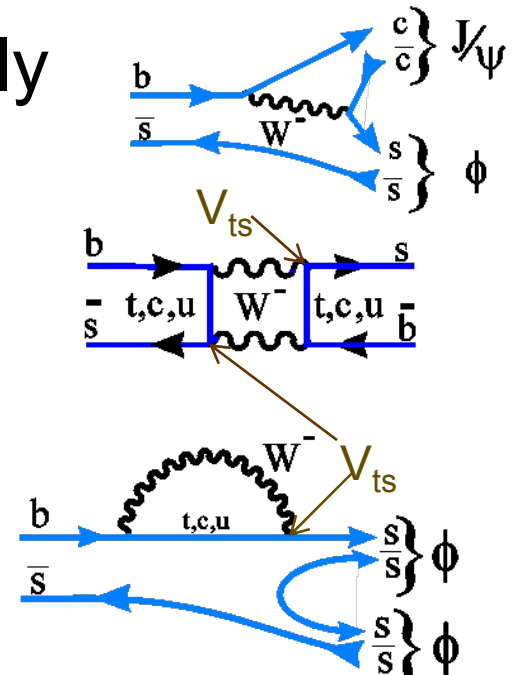

J/ψ rest frame

ϕ rest frame

Technique

- Without S-waves & $\Delta\Gamma=0$

$$A(B_s \rightarrow J/\psi\phi) = A_0(m_\phi)/E_\phi \epsilon_{J/\psi}^{*L} - A_{\parallel} \epsilon_{J/\psi}^{*T}/\sqrt{2} - iA_{\perp} \epsilon_{\phi}^* \cdot \hat{\mathbf{p}}/\sqrt{2},$$

- A_0 P=+ longitudinal, A_{\parallel} P=+ trans, A_{\perp} P= - trans

$$\frac{d^4\Gamma[B_s \rightarrow (\ell^+\ell^-)_{J/\psi}(K^+K^-)_{\phi}]}{d\cos\theta d\phi d\cos\psi dt} = \frac{9}{32\pi} [2|A_0|^2 \cos^2\psi (1 - \sin^2\theta \cos^2\phi) + \sin^2\psi \{ |A_{\parallel}|^2 (1 - \sin^2\theta \sin^2\phi) + |A_{\perp}|^2 \sin^2\theta - \text{Im}(A_{\parallel}^* A_{\perp}) \sin 2\theta \sin\phi \} + \frac{1}{\sqrt{2}} \sin 2\psi \{ \text{Re}(A_0^* A_{\parallel}) \sin^2\theta \sin 2\phi + \text{Im}(A_0^* A_{\perp}) \sin 2\theta \cos\phi \}] .$$

- For \overline{B}_s replace A_{\perp} by $-A_{\perp}$.
- S-Wave term cannot be ignored (Stone & Zhang [[arXiv:0812.2832](https://arxiv.org/abs/0812.2832)])
- Must add in S-wave amplitude and finite $\Delta\Gamma$.

All terms [Xie et al, arXiv:0908.3627]

- Time dependence (for ex.)

$$|A_0(t)|^2 = |A_0|^2 e^{-\Gamma_s t} \left[\cosh\left(\frac{\Delta\Gamma_s t}{2}\right) - \cos\Phi \sinh\left(\frac{\Delta\Gamma_s t}{2}\right) + \sin\Phi \sin(\Delta m_s t) \right]$$

- Can write $\frac{d^4\Gamma(B_s^0 \rightarrow J/\psi K^+ K^-)}{dt d\cos\theta d\cos\psi d\varphi} \propto \sum_{k=1}^{10} h_k(t) f_k(\Omega)$

k	$h_k(t)$	$\bar{h}_k(t)$	$f_k(\theta_l, \theta_K, \varphi)$
1	$ A_0(t) ^2$	$ \bar{A}_0(t) ^2$	$4 \sin^2 \theta_l \cos^2 \theta_K$
2	$ A_{ }(t) ^2$	$ \bar{A}_{ }(t) ^2$	$(1 + \cos^2 \theta_l) \sin^2 \theta_K - \sin^2 \theta_l \sin^2 \theta_K \cos 2\varphi$
3	$ A_{\perp}(t) ^2$	$ \bar{A}_{\perp}(t) ^2$	$(1 + \cos^2 \theta_l) \sin^2 \theta_K + \sin^2 \theta_l \sin^2 \theta_K \cos 2\varphi$
4	$\Im\{A_{ }^*(t)A_{\perp}(t)\}$	$\Im\{\bar{A}_{ }^*(t)\bar{A}_{\perp}(t)\}$	$2 \sin^2 \theta_l \sin^2 \theta_K \sin 2\varphi$
5	$\Re\{A_0^*(t)A_{ }(t)\}$	$\Re\{\bar{A}_0^*(t)\bar{A}_{ }(t)\}$	$-\sqrt{2} \sin 2\theta_l \sin 2\theta_K \cos \varphi$
6	$\Im\{A_0^*(t)A_{\perp}(t)\}$	$\Im\{\bar{A}_0^*(t)\bar{A}_{\perp}(t)\}$	$\sqrt{2} \sin 2\theta_l \sin 2\theta_K \sin \varphi$
7	$ A_S(t) ^2$	$ \bar{A}_S(t) ^2$	$\frac{4}{3} \sin^2 \theta_l$
8	$\Re\{A_S^*(t)A_{ }(t)\}$	$\Re\{\bar{A}_S^*(t)\bar{A}_{ }(t)\}$	$-\frac{2}{3} \sqrt{6} \sin 2\theta_l \sin \theta_K \cos \varphi$
9	$\Im\{A_S^*(t)A_{\perp}(t)\}$	$\Im\{\bar{A}_S^*(t)\bar{A}_{\perp}(t)\}$	$\frac{2}{3} \sqrt{6} \sin 2\theta_l \sin \theta_K \sin \varphi$
10	$\Re\{A_S^*(t)A_0(t)\}$	$\Re\{\bar{A}_S^*(t)\bar{A}_0(t)\}$	$\frac{8}{3} \sqrt{3} \sin^2 \theta_l \cos \theta_K$

Effects of S-wave

- Adding A_S can only increase the experimental error. The size of the effect depends on many factors including the magnitude & phase of the S-wave amplitude, β_S , values of the strong phases, detector acceptances, biases..

Congratulations to CDF

- CDF added S-wave into β_s fit
- They find that the fitted fraction of K^+K^- S-wave in the signal region is $<6.7\%$ at 95% c.l.
- See Louise Oakes, talk at FPCP, Torino, May 2010.

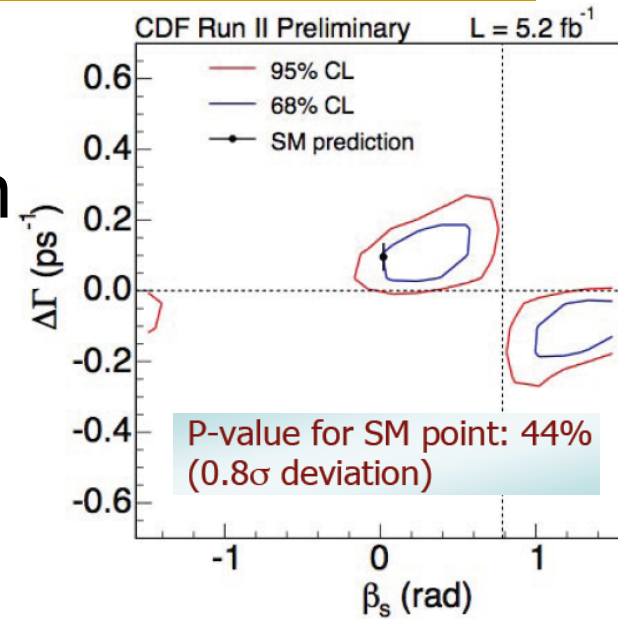

Estimates of $J/\psi f_0(980)$

- Can use S-wave materializing as $f_0(980)$ for CP measurements (Stone & Zhang [[arXiv:0812.2832](https://arxiv.org/abs/0812.2832)])
- The final state $J/\psi f_0$ is a CP+ eigenstate
- No angular analysis is necessary! This is just like measuring $J/\psi K_s$. The modes $J/\psi \eta$ & $J/\psi \eta'$ can also be used, but they involved γ 's in the decay & thus have lower efficiency at hadron colliders
- Define:
$$R_{f/\phi} = \frac{\Gamma(B_s \rightarrow J/\psi f_0; f_0 \rightarrow \pi^+ \pi^-)}{\Gamma(B_s \rightarrow J/\psi \phi; \phi \rightarrow K^+ K^-)}$$

Theory Estimates of $\mathcal{R}_{f_0/\phi}$

- Colangelo, De Fazio & Wang [arXiv:1002.2880]
- Use Light Cone Sum Rules at leading order
- Prediction 1: Using measured $\mathcal{B}(J/\psi \phi) = (1.3 \pm 0.4) \times 10^{-3}$
 - $\mathcal{B}(J/\psi f_0) = (3.1 \pm 2.4) \times 10^{-4}$ (0th order), $R = 24\%$
 - $\mathcal{B}(J/\psi f_0) = (5.3 \pm 3.9) \times 10^{-4}$ (leading order), $R = 41\%$
- Prediction 2: Using ff for ϕ from Ball & Zwicky [arXiv:hep-ph/0412079]
 $R_L = 0.13 \pm 0.06$ (0th order),
 $= 0.22 \pm 0.10$ 1st order

$$R_L = \frac{B(B_s \rightarrow J/\psi f_0)}{B(B_s \rightarrow J/\psi \phi_L)}$$

QCD Factorization

- O. Leitner et al [arXiv:1003.5980]
 - Assume $f_{B_s} = 260$ MeV, $f_{f_0} = 380$ MeV
- Predict $\mathcal{B}(B_s \rightarrow J/\psi f_0) = 1.70 \times 10^{-4}$.
- $\mathcal{B}(B_s \rightarrow J/\psi \phi) = 9.30 \times 10^{-4}$.
- $R_{f_0/\phi} = 0.187$. They show small variation with $B_s \rightarrow f_0$ form factor; “annihilation” effects important and decrease f_0 rate.
- “S-wave kaons or pions under the ϕ peak in $J/\psi\phi$ are very likely to originate from the similar decay $J/\psi f_0$. Therefore, the extraction of the mixing phase from $J/\psi\phi$ may well be biased by this S-wave effect which should be taken into account in experimental analysis”

Summary of \mathcal{R} estimates

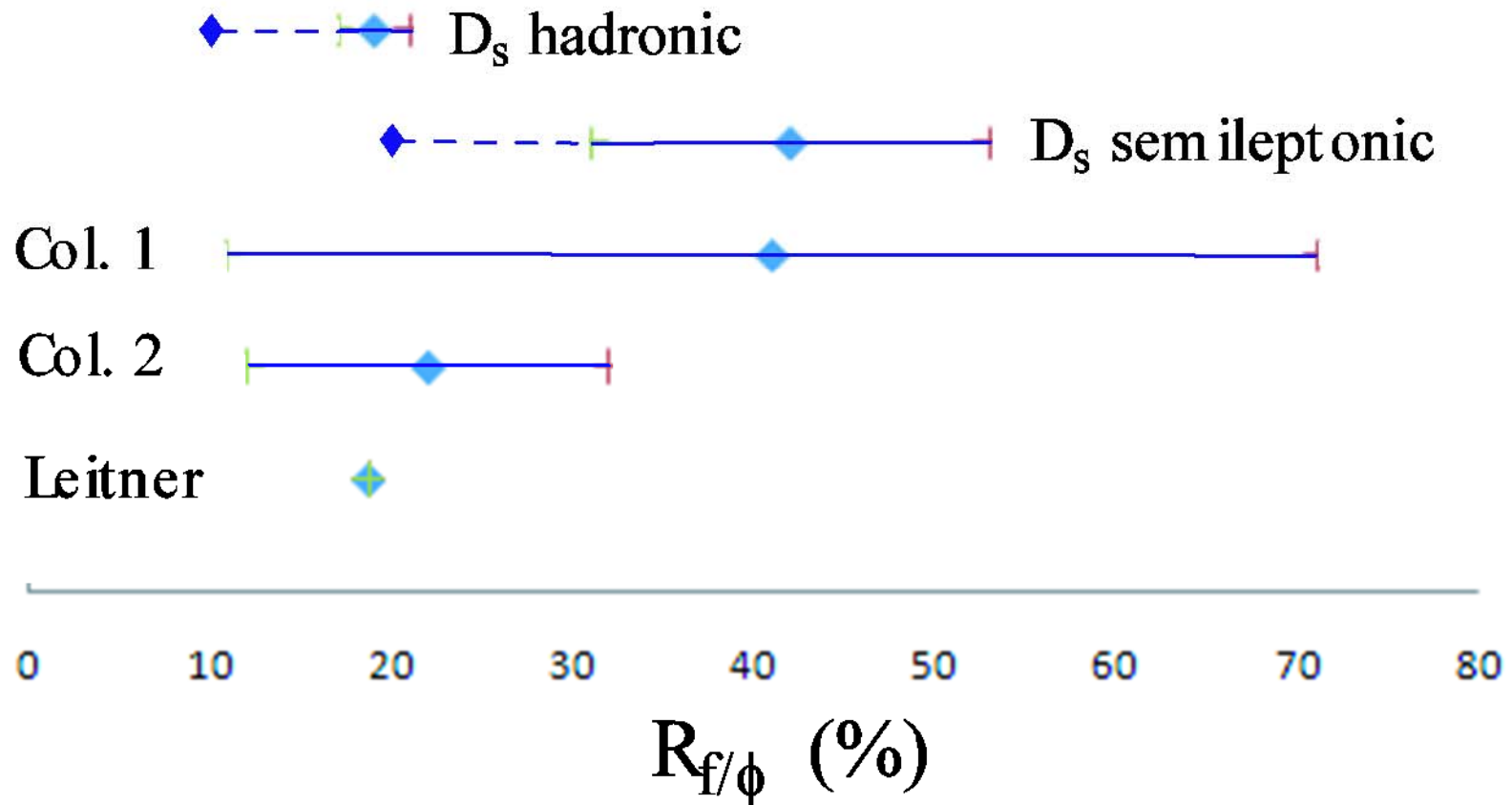

- Measurement will constrain theories

BELLE Results

- Using $\sim 25 \text{ fb}^{-1}$ of Y(5S) data, Belle sets limits:

$$\mathcal{B}(B_s^0 \rightarrow J/\psi f_0) \times \mathcal{B}(f_0 \rightarrow \pi^+ \pi^-) < 1.63 \times 10^{-4} \text{ @ } 90\% \text{ c.l.}$$

$$R_{f_0/\phi} < 0.275 \text{ @ } 90\% \text{ C.L.}$$

See R. Louvot, FPCP
Torino, 2010

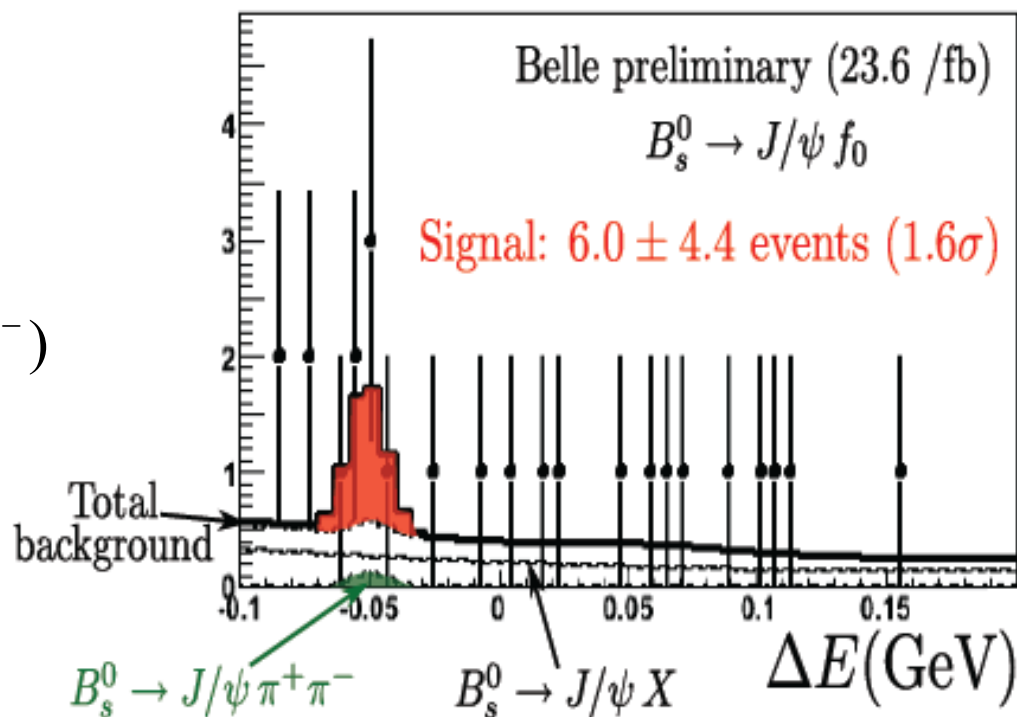

Conclusions

- S-waves are ubiquitous, they appear whenever looked for, & must be taken into account in $B_s \rightarrow J/\psi \phi$ measurements of amplitudes, phases, & CP violation
- In addition: add S-wave amplitudes in the analysis of $B \rightarrow K^* \mu^+ \mu^-$ & surely in $B_s \rightarrow \phi\phi$
- $B_s \rightarrow J/\psi f_0$ may be a useful mode to add to the statistical precision on the measurement of $-2\beta_s$, & hopefully will provide useful checks since angular measurements are not necessary



The

End

Check on Prediction

- Note that Colangelo et al predict
- $\mathcal{B}(D_s \rightarrow f_0 e^+ \nu) = \left(2.0^{+0.5}_{-0.4}\right) \times 10^{-3}$,
- While CLEO measures
- $\mathcal{B}(D_s \rightarrow f_0 e^+ \nu) = (4.0 \pm 0.6 \pm 0.6) \times 10^{-3}$,
- Which implies that the calculated form-factor is low by a factor of 2, thus compensating for $\Gamma_{\phi_L} / \Gamma_{\text{total}} = 0.53$

Results of ignoring S -wave

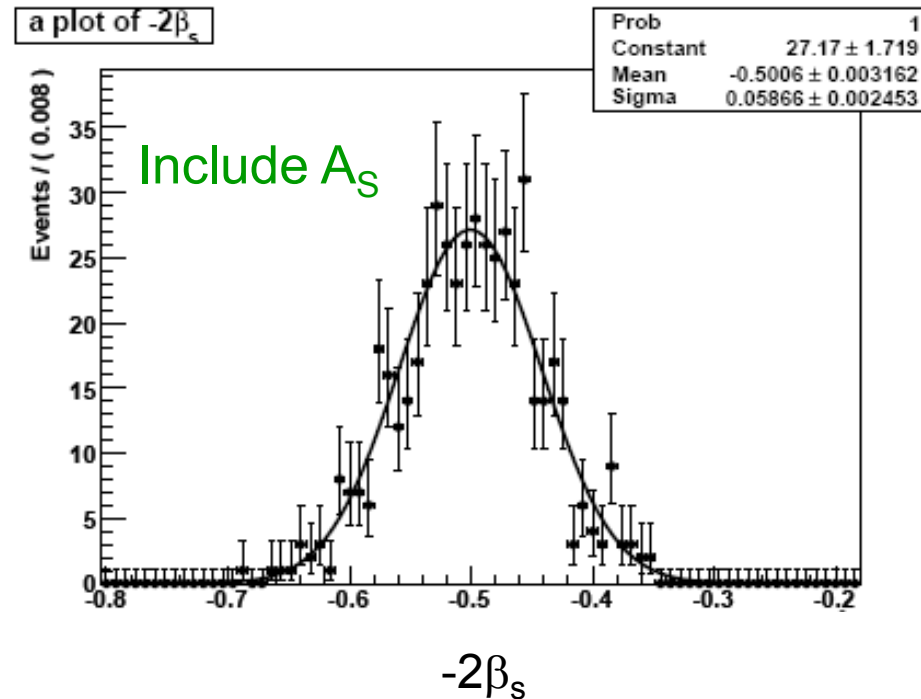
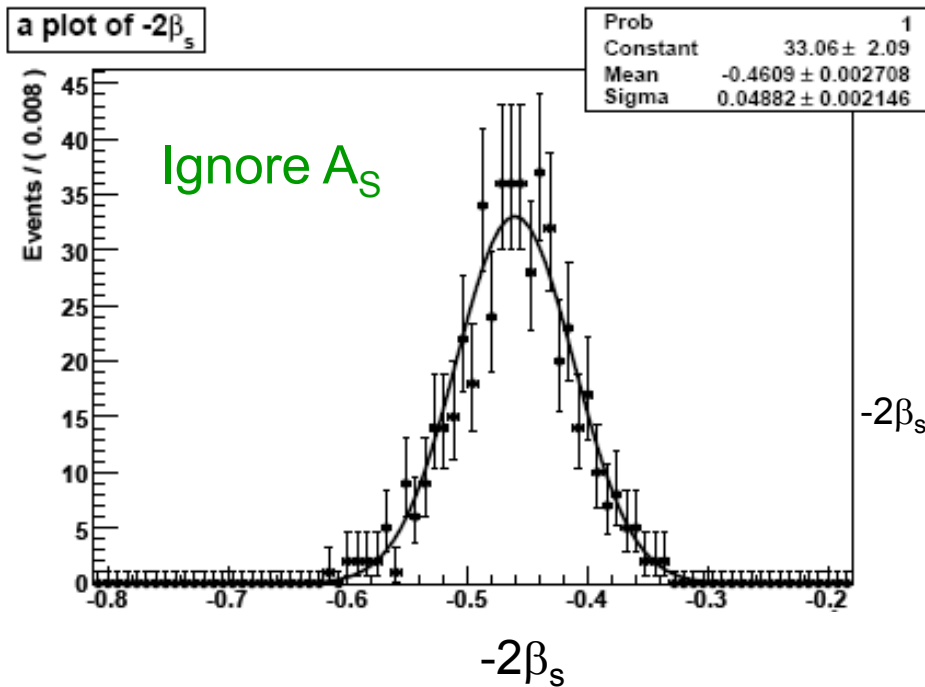

- Find bias of -10%
- Error increases by ~15%.
- Can also use to eliminate δ_s ambiguity

Estimate of S-wave Effect

- Adding A_S can only increase the experimental error. The size of the effect depends on many factors including the magnitude & phase of the S-wave amplitude, β_S , values of the strong phases, detector acceptances, biases..
- One simulation for LHCb by Xie et al
 - Assumes either 5% or 10% S-wave with phases either 0 or 90°.
 - Simulates many Pseudo experiments

Estimate Using Hadronic D_s Decays

- $M(B_s) - M(J/\psi) = 5366 - 3097 = 2270$ MeV
- $M(D_s) - M(\pi) = 1830$ MeV, not too different

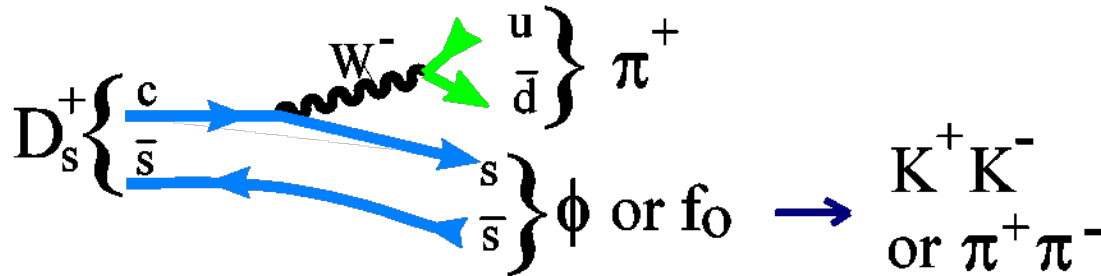

- Use CLEO result for $D_s \rightarrow K^+ K^- \pi^+$ extrapolated to zero ϕ width to extract $\mathcal{B}(D_s \rightarrow \phi \pi^+, \phi \rightarrow K^+ K^-) = (1.6 \pm 0.1)\%$

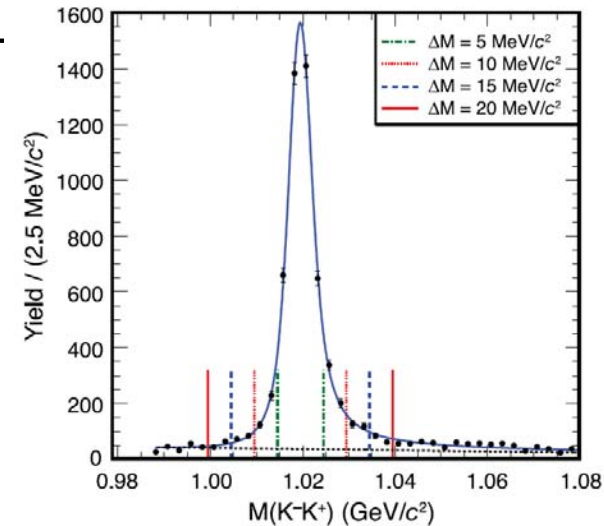

Estimate from $D_s \rightarrow h^+ h^- \pi^+$

- CLEO: $\mathcal{B}(D_s \rightarrow \pi^+ \pi^+ \pi^-) = (1.11 \pm 0.07 \pm 0.04)\%$
- Use BaBar Dalitz analysis to estimate fraction of $f_0 \pi^+$ [arXiv:0808.0971]

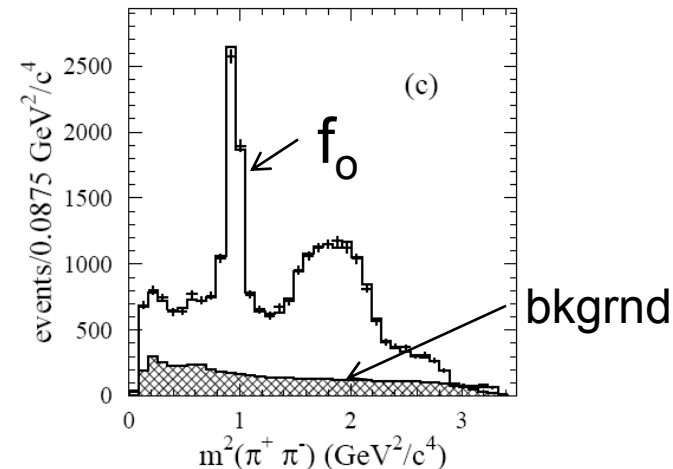
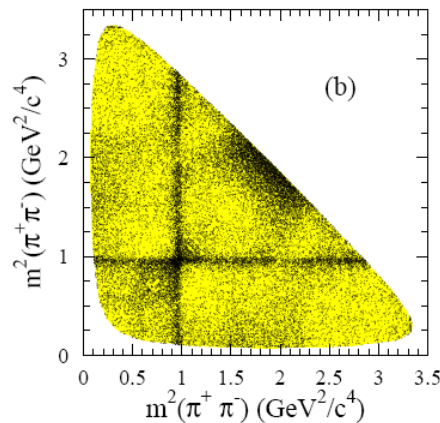
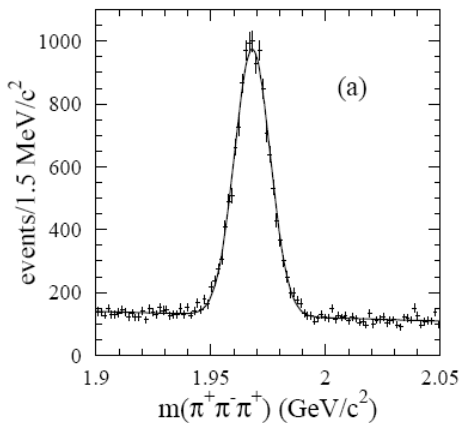

- Estimate $(27 \pm 2)\%$ of final state is in narrow f_0 peak

$$R'_{f/\phi} = \frac{\Gamma(D_s \rightarrow f_0 \pi^+; f_0 \rightarrow \pi^+ \pi^-)}{\Gamma(D_s \rightarrow \phi \pi^+; \phi \rightarrow K^+ K^-)} = (19 \pm 2)\%$$

There is more S-wave under f_0 peak

β_s Sensitivity Using $J/\psi f_0$

- From Stone & Zhang [arXiv:0909.5442] for LHCb
- Assume $R_{f_0/\phi} = 25\%$
- Assume 2 fb^{-1} at 14 TeV ($\sim 4 \text{ fb}^{-1}$ at 7 TeV)
- Error in $-2\beta_s$
 - $J/\psi \phi$: ± 0.03 rad (not including S-wave)
 - $J/\psi f_0, f_0 \rightarrow \pi^+\pi^-$: ± 0.05 rad
 - $J/\psi f_0 + J/\psi \eta', \eta' \rightarrow \pi^+\pi^-\gamma$: ± 0.044 rad
- The f_0 mode should be useful

$B_s \rightarrow J/\psi f_0$ Signal Selection

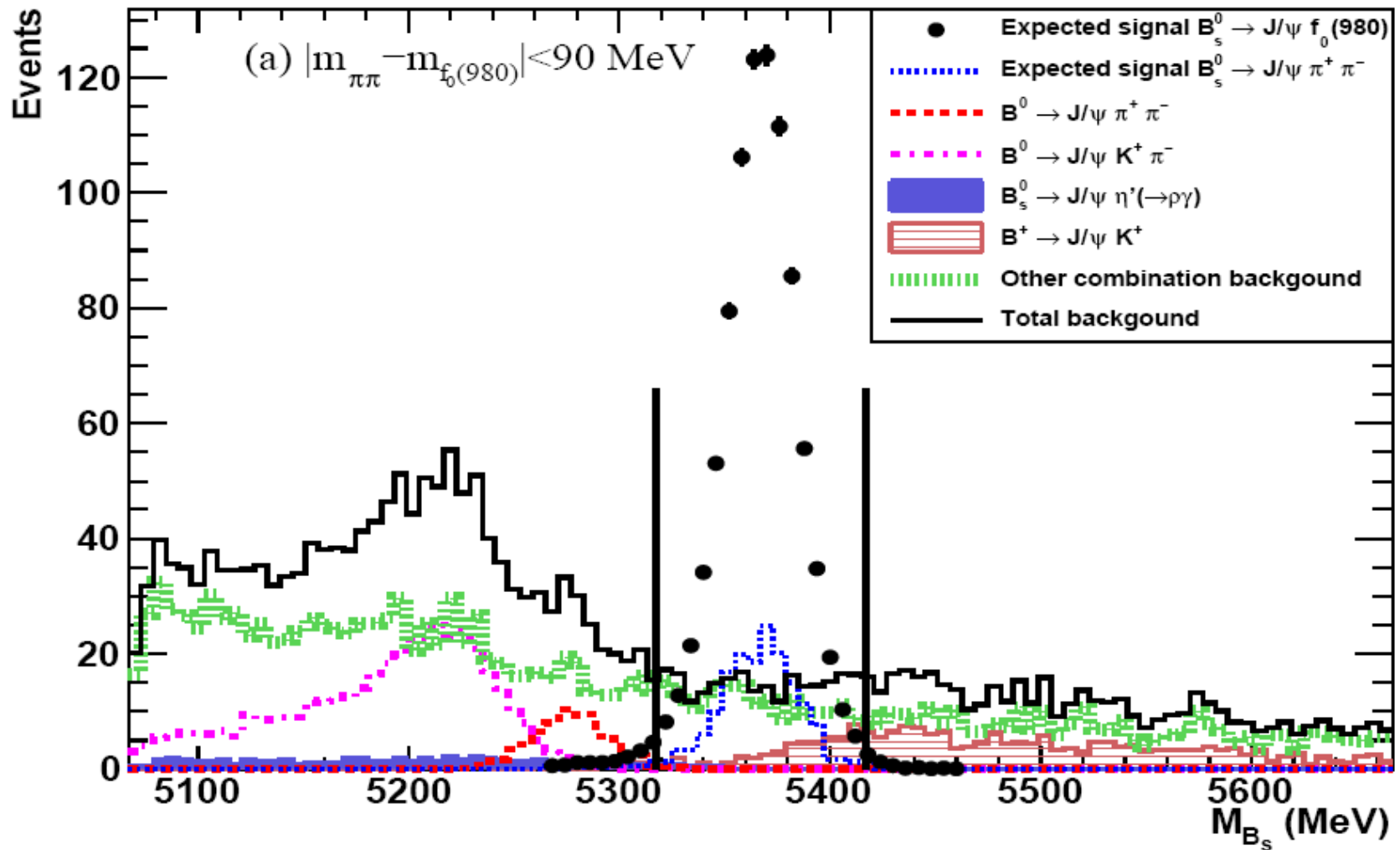

Estimate from $D_s \rightarrow (\phi/f_0) e^+ \nu$

- Compare semileptonic rates near $q^2=0$ to get maximum phase space
CLEO [arXiv:907.3201]

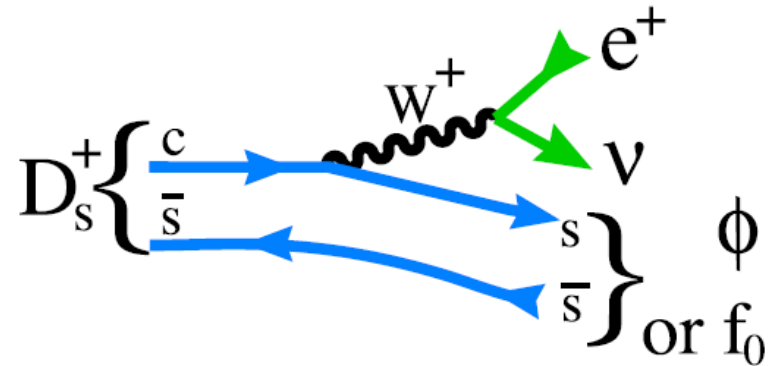

$$\frac{d\Gamma}{dq^2}$$

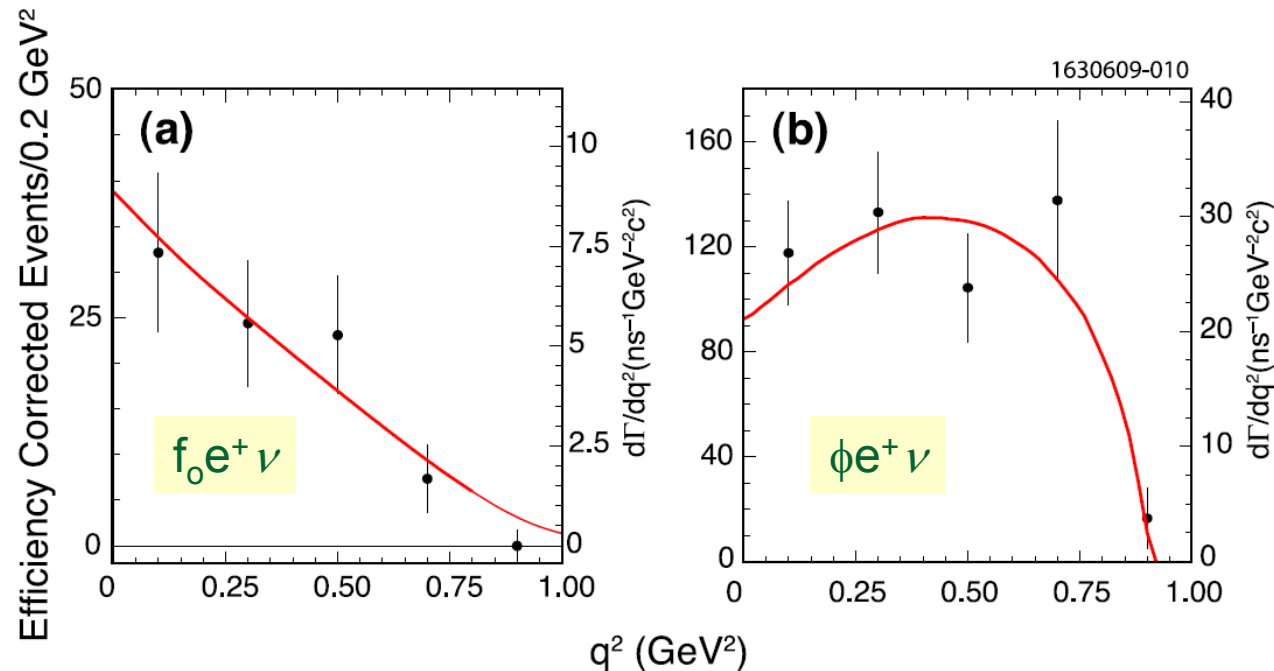

Semileptonic estimate

- At $q^2=0$, where phase space is closest to $B_s \rightarrow J/\psi(\phi/f_0)$
- $$R_{f/\phi} \equiv \frac{\frac{d\Gamma}{dq^2}(D_s^+ \rightarrow f_0(980)e^+\nu, f_0 \rightarrow \pi^+\pi^-) |_{q^2=0}}{\frac{d\Gamma}{dq^2}(D_s^+ \rightarrow \phi e^+\nu, \phi \rightarrow K^+K^-) |_{q^2=0}} = (42 \pm 11)\%$$
- Note that at $q^2=0$ and in the case of $D_s \rightarrow \phi\pi$, the ϕ is forced into a longitudinal polarization state
- CDF measures only 53% ϕ_L , so these rates may be too large by x2