

# OPTIMISE INTERVENTIONS AND RECOVERY FROM COLLATERAL DAMAGES ON COLD SECTORS

Caroline Fabre and Pierre Strubin, CERN, Geneva, Switzerland

## INTRODUCTION

The collateral damages during the incident in sector 3-4 accounted for a very significant, if not the main, part of the time spent to repair and restore this sector to an operational state. Many compensatory measures have been taken to minimise collateral damages should such an incident ever happen again. However, not all can be avoided. This session was therefore devoted to the optimisation of interventions in cold parts of the LHC. Topics covered the range from cleaning the beam vacuum pipe to exchanging a magnet without warming-up a full 2.8 km sector.

## CAN WE OPTIMISE THE CLEAN UP PROCESS FURTHER?

(Vincent Baglin, TE.VSC)

One of the most time consuming event to recover from the incident in sector 3-4 was to remove all debris from the vacuum beam pipes and clean the latter from soot in some areas. Large amounts of debris, mainly from the multi-layer insulation (MLI), were blown from the location of the incident towards both ends of the sector, in both beam pipes.

The rescue activities started with an in-depth inspection, using an endoscope, of the 4.8 km of affected beam pipes and with a careful documentation of all findings. Table 1 summarises the extent of the damage.

	V1	V2	V1	V2	Total
Ok	54	39	26 %	18 %	22 %
MLI	124	129	58 %	61 %	59 %
Soot	35	45	16 %	21 %	19 %
Total	213	213	100 %	100 %	100 %

Table 1: result of the endoscopic inspection of the beam vacuum pipes after the 3-4 incident

The next step was to develop adequate tooling to remove the debris and clean the soot. For the debris, a method combining alternated pumping and venting cycles and a kind of “vacuum cleaner” was developed and successfully tested. The “vacuum cleaner” was mounted at the extremity of the endoscope, to allow monitoring in real time the progress of cleaning. To remove the soot, a large “cleaning stick” using foam, wetted by alcohol, was used. These various tools were thoroughly tested in the laboratory before deploying them in the LHC tunnel. A definition of acceptable cleanliness was agreed on between the vacuum group and the accelerator and beam

physics group. For the debris, 1 fibre per half-cell (resulting in 82 half-cells to clean) and 2 pieces of debris (MLI or other less than 1 mm<sup>2</sup>) per magnet (resulting in 304 beam tube magnets to clean) could remain. For the soot, the result was deemed acceptable when the foam was no longer changing colour after a passage in the beam pipe.

Three teams working in parallel were then sent to the LHC tunnel, achieving a rate of 50 m per day, of which almost half was devoted to cleaning the plug-in modules (PIMs). A final inspection with the endoscope was made before closing the vacuum system. Figure 1 shows the associated dashboard.

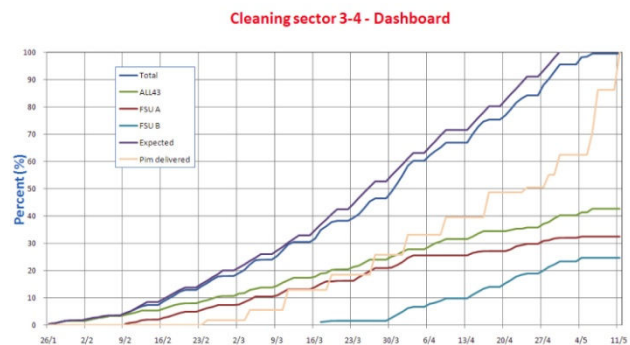

Figure 1: Dashboard of the cleaning campaign

The main difficulties encountered were essentially the result of not being prepared to such an incident. It was very difficult initially to know and understand what had happened. Then came need to build-up a team of experts on a new task and the need to identify, build, buy and qualify the adequate tooling. Operational difficulties were also many, e.g. how to distinguish with an endoscope a fibre or a MLI from a scratch or a stain?

The total time needed for sector 3-4 was 6 months, 3 months to develop and test the tooling and 3 months to do the actual work. Today, we have 6 sets of tooling available, which should reduce the total time to about 3 months should such an incident ever happen again.

## WHAT IS THE MCI IN CASE OF A “BEAM DRIVEN” FAILURE OF A MAGNET ENCLOSURE?

(Rob van Weelderden, TE-CRG)

The incident in sector 3-4 affected the beam vacuum because the arc which developed damaged the closest bellows and allowed for the helium to rush in and propagate debris. It also caused an overpressure in the beam pipes, which resulted in some other bellows to be damaged, although without breaking. Another possible incident is the beam damaging the vacuum enclosure in a magnet. It is therefore of interest to try and assess the

worst case of pressure development and propagation in such an event.

The flow rate is estimated by the sound velocity limit of the escaping helium through the slits formed by the magnet laminations. The slit area is  $3.23 \text{ cm}^2 \text{ m}^{-1}$  (0.2 mm gap per 6.2 mm length, 10 mm hole width) and there are around 161 slits per metre length. The specific discharge values are determined by the state of the helium at the location of the hole and thus by the physical process taking place in the cold masses. Table 2 summarises the different possibilities.

	Specific (kg/s cm <sup>2</sup> )	Per slit (kg/s)	Per meter of collar nose (kg/s.m)
Pool boiling vapour phase	0.22	0.004	0.71
Pool boiling liquid phase	2.0	0.039	6.3
Isochoric	3.9	0.078	12.6
adiabatic	4.3	0.085	13.7
reality	?	?	?

Table 2: various assumptions and corresponding helium flow rates

Data collected during quenches show that the first 15 seconds seem to follow an adiabatic/isochoric phase with pressures to 3-4 bars and a temperature around 3 K. During this first phase, the helium is still in liquid phase and the flow can be as high as  $4 \text{ kg s}^{-1} \text{ cm}^{-2}$  or  $10 \text{ kg s}^{-1}$  per metre of lamination. This flow could even be higher if the hole is punched in the magnet ends, where no laminations reduce the conductance. After this first phase, the helium temperature increases due to the heat released in the magnet during the quench. The associated decrease in helium density leads the discharge rate to decrease by an order of magnitude ( $\sim 0.7 \text{ kg s}^{-1} \text{ cm}^{-2}$  or  $\sim 1.7 \text{ kg s}^{-1}$  per metre of lamination). It has also to be noted that when neighbour magnets are quenched, the average long-term discharge is significantly gentler than during the first few seconds. However, quenching magnets is not recommended as a protection mechanism, as the stresses on the magnets are not harmless.

In view of this wide range of possible mass flows, specific cases of reasonable beam damages will now have to be defined in order to evaluate the pressure level and propagation in the beam pipe.

### Means to limit the collateral damages in the beam vacuum chamber

(José Miguel Jimenez, TE-VSC)

The protection of the LHC beam vacuum system has been designed to limit the impact of small air or helium leaks, typically in welds, seals, feedthroughs or in the beam screen cooling tubes. It consists in a protection against overpressure in every sector, by means of a rupture disk breaking at 1.5 bar. The choice for this simple way of protection was based on the risk analysis of the cryogenic system (LHC Project Note 177, 1999), where the flow rate was not assumed to be larger than  $2 \text{ kg s}^{-1}$ , an order of magnitude lower than what happened

in sector 3-4. An incident similar to the one in sector 3-4 but with very limited damage happened on the test string, but unfortunately this incident did not trigger much worry.

The beam vacuum system is split into sectors by valves. There is at least one valve at each cold to warm transition. However, there is no valve over the full length of the continuous cryostat in the arcs. The following summarises the protection for the beam vacuum system:

#### Arcs

- Rupture disks (30 mm aperture) at each arc extremity ( $\sim 3 \text{ km}$ )
- No vacuum sectorisation !

#### Standalone magnets (SAM)

- Rupture disks (30 mm aperture) available at extremity of each SAM
- Vacuum sector valves at each extremities (isolate from the warm vacuum sector)

#### Long straight sections room temperature vacuum sectors

- Vacuum sector valves (sectors at RT can always be isolated from SAM)

#### Experimental areas

- Vacuum sector valves at Q1 (each side) and to isolate the central beam pipes
- Pressure relief valve (only in LHCb Velo)

The protection has to be improved to avoid damages to the bellows in the cold parts and to limit the contamination of the beam vacuum by debris or soot.

To protect the bellows against over pressure, one can add more rupture disks. However, the low conductance of the beam pipe limits the efficiency of the rupture disks. Besides, adding 2 half-shells in Vetronite or equivalent around the bellows will increase the resistance to plasma discharge (high temperature resistance), avoid damages induced by the projections of melted metal and also help limiting the injection of MLI in the beam vacuum in case of an arc as in sector 3-4.

To minimise the contamination over long distances, one can think of adding fast valves. They shall not be necessarily leak tight but must close within 20-50 ms. If one uses a low-Z material for the sealing plate, the valve may even survive an accidental closure with beam. However, installing fast valves requires very reliable interlock signals which could come from the beam loss monitors when beam is circulating, from pressure gauges or the new quench protection system (nQPS) in the absence of circulating beams. This is a new development, requiring thorough risk analysis, validation and tests.

### WHAT REPAIR ACTIVITY CAN BE DONE TODAY ON A LOCALLY WARMED-UP SUB-SECTOR?

(Paul Cruikshank, TE-VSC)

Local warm-up was foreseen in the baseline for repairs at interconnects on the cold mass volume (diode, busbar, splice, helium leak, IFS, line N) or instrumentation BUT

NOT for repairs on beam vacuum or circuits without valves (line c',k,e,x,y). The scenario was defined in the LHC Project Report 60, Sept 2000, where three sub-sectors had to be warm-up, one where the intervention had to take place and one on each side to serve as thermal buffers to prevent condensation on vacuum barriers. Figure 2 shows the principle.

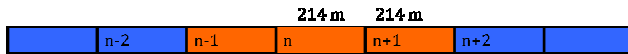

Figure 2: principle of local warm-up as per baseline  
 n-2... floating, cold, under vacuum  
 n-1 thermal buffer, RT, under vacuum  
 n intervention, RT, vented, W opened 642m (23%) at RT  
 n+1 thermal buffer, RT, under vacuum  
 n+2... floating, cold, under vacuum

Some experience was gained in 2007 with this scenario when flexible hoses had to be replaced on the DFBA in sector 4-5.

A new scenario was studied to allow warming-up only one vacuum sub-sector, in order to limit the number of PIMs which undergo thermal cycle to room temperature. Some precautions had to be taken to avoid condensation on the one magnet (SSS) which belongs to the neighbour cold cryogenics sub-sector. This magnet can be warmed-up by circulating warm nitrogen in the beam pipes, a method which has been fully validated in SM18 on a real magnet. This is illustrated on figure 3.

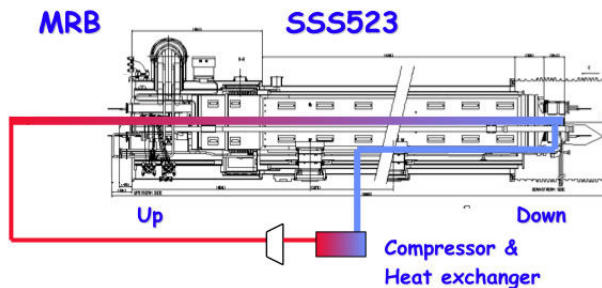

Figure 3: Principle of warming-up the first cold mass of the adjacent cold sector

The next difficulty is to be able to inspect and possibly change the plug-in-modules (PIMs) at the warm extremity of the SSS. The solution is a small flow of  $5\text{mm s}^{-1}$  of  $\text{N}_2$  or Ne to avoid retro-diffusion of air into the beam pipe, hence avoid accumulating condensed water on the vacuum chamber. With this technique, the inspection of PIMs with an endoscope could be done under Ne flow in sectors 2-3 and 8-1.

Warming-up a single sub-sector could allow reducing the time requested for an intervention from 69 to 53 days, as compared to a full sector warm-up. However, it is a very delicate operation when the beam vacuum has to be opened and blown through! Besides, local warm-up of an SSS inducing stress on the weld between cold bore and cold mass, this method should not be used massively. One should also keep in mind that the new X-ray tomograph has been received and commissioned in the tunnel and should become the preferred way of inspecting PIMs or other components on the cold part.

## CAN WE CHANGE A MAGNET WITHOUT WARMING-UP A FULL ARC?

(Serge Claudet, TE-CRG)

The official answer from the baseline is: NO. But things may change and may be reconsidered... As the cold mass and line N are sectorised, these items are not a problem. But lines X/Y (bayonet HX), line C' (cooling intercept), line E (thermal shield) are not sectorised, hence air would reach cold surfaces in the cold sub-sectors and get trapped. It is therefore worth to look at the methods that are used for the beam vacuum, using a flow of dry gas (nitrogen, neon or more likely helium). Cutting out bellows has hence to be made with a slight over-pressure (had already been done inadvertently, hence known to work...). After cutting, one can install temporary caps on the opened pipes, with a gaseous He flow when fixing in place (kind of clamp + screw plug) in order to prevent retro-diffusion and condensation. More delicate will be the welding of the bellows after the magnet has been changed, in particular for the last bellows, where precise control of the He backing flow is required. The issues are both about the quality of the weld and about the safety of the intervening personnel. One can think of a pseudo leak-tight sleeve with an exhaust for the backing gas before welding the lips, then welding of a plug on this exhaust at the end. Figure 4 shows sketches of such solutions.

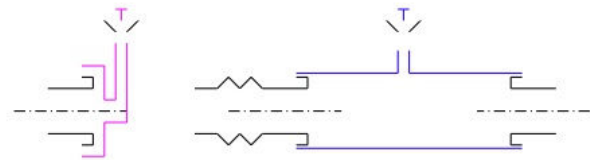

Figure 4: protecting the pipes against retro-diffusion of air

It has to be noted that it may be required to warm-up two sub-sectors rather than only one to allow for the electrical quality procedure on line N.

As there are clearly advantages to privilege a local warm-up versus a full-sector warm-up (both in terms of time and cost and because it limits the number of PIMs and magnets cycled to room temperature), it is worth to invest more in a common study with the vacuum and magnet groups to define and validate the various steps and procedures so as to minimize later disruptions of the operation of the cryogenic and vacuum systems.

## DECOUPLING OF ADJACENT CRYOGENIC SECTORS

(Gérard Ferlin, TE-CRG)

The present LHC cryogenic sectorisation allows performing mechanical interventions on the circuits of the magnet cold-mass of a sector, like replacing diode or repairing interconnection splices, while the adjacent sector remains in nominal cryogenic operation. However this sectorisation does not allow exchanging a magnet or a QRL service module in a sector while keeping the

adjacent sector in nominal cryogenic operation and while preserving the redundancy of the two cooling plants available at each point.

Requirements for the interventions on one sector are coming from safety aspects (sector must be locked-out from pressure and gas flow) and from cryogenic operation aspects (protect cold valves from air and moisture condensation). This is achieved today by having for each circuit 2 valves with a helium gas buffer in between (at room temperature and 1 bar). This solution is applicable for all circuits except header B (gaseous He pumping line, 15 mbar, 4K).

Two options are proposed to improve the decoupling of adjacent sectors. The first option is to add a DN250 valve on header B which would allow safe intervention on any sector while keeping the adjacent one cold. However the redundancy of the two cooling plants in one point is lost during intervention. The two sectors have to be warmed-up to install this additional valve. The second option is to add a new valve-box with 6 cryogenic valves on the junction region of the QRL. This second option restores the redundancy of the cryoplants in addition to allow for safe interventions. As for the first option, the two sectors have to be warmed-up to install this additional valve-box. Figure 5 gives a schematic of the He distribution circuits and the possible options.

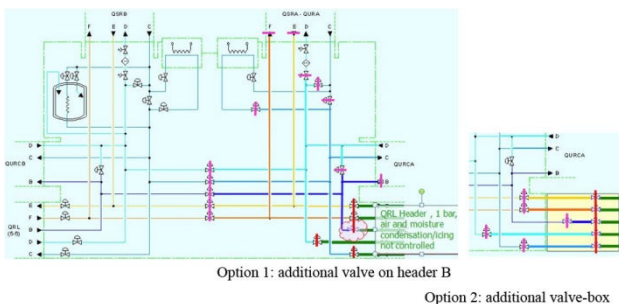

Figure 5: schematic of the He distribution in a typical site

There are possibilities to improve the cryogenic decoupling of two adjacent sectors, but they both require a validation of the design and a thorough integration study.

## CONCLUSIONS

The incident in sector 3-4 created a lot of secondary damage, among them the pollution of the beam vacuum system with debris and soot. The cleaning campaign required careful inspection to evaluate the extent of the contamination. Specific tooling was built and used in the tunnel, allowing cleaning the 4.8 km of beam pipes and the interconnecting modules (PIMs) to a level deemed acceptable by all concerned parties. The protection of the beam vacuum system was scrutinised and can probably be improved with the addition of fast closing valves and protection shells on the bellows.

But the incident also triggered a number of new ideas to minimise the consequences in terms of intervention time, cost and risk should such an incident happen again.

Limiting the number of sub-sectors to warm-up for an intervention, changing a magnet with a local warm-up and improving the operational separation between adjacent cryogenic sectors count among these new ideas. They are all worth further study and validation.

Finally, the basic hypothesis to evaluate the most credible incident (MCI) in case the beam perforates the helium enclosure in a magnet have been defined and can now be used to build-up credible scenarios.