

Silicon Pixel Tracker (SPT) for CLIC

Chris Damerell (RAL)

CONTENTS

- **Goals and design principles**
- **SPT at CLIC - suggested architecture and track reconstruction procedure**
- **Charge-coupled CMOS pixels – a breakthrough for scientific imaging**
- **Conclusions**

Goals and design principles

- For past two years, a few of us have started to consider a new approach to tracking at the LC (which is even better matched to CLIC than to ILC)
- **Goal is excellent track reconstruction efficiency and precision, down to the minimum polar angle, with high transparency for photons**
- Eliminate all material that isn't strictly necessary in the tracking volume
- Explore a monolithic pixel architecture for the (five) **tracking layers** ($\sim 50 \mu\text{m}$ pixels), since a pixel layer can be made thinner than a microstrip layer, and as regards track finding, **one pixel layer is worth far more than two strip layers**
- Integrate signals through the bunch train, EXCEPT for an **outer timing layer** just in front of the ECAL, and (probably) an **inner timing layer** between vertex layers and tracker layers. Hybrid pixels, larger than for tracker ($\sim 150 \mu\text{m}$?), but 10 ns or better timing resolution.
- Track densities are sufficiently low that it will be possible to almost perfectly follow each on-time track through the tracking layers and through the vertex detector layers to the IP (or the decay point, if this is beyond the vertex detector inner layer)
- By reading out the **tracking layers** steadily between trains, we avoid the mechanical and thermal issues of **pulsed power**. In our case, peak power = average power, and power levels can be comfortably handled by a gentle flow of cooling gas (hence minimising the material budget). **Timing layers** (probably attached to ECAL) will be liquid cooled and use pulsed power – no disincentive to that

- Apart from the judiciously located timing layers (~2% X_0 per layer?), the tracking system (closed barrel with endcaps) can achieve ~0.6% X_0 per layer. Ambitious!

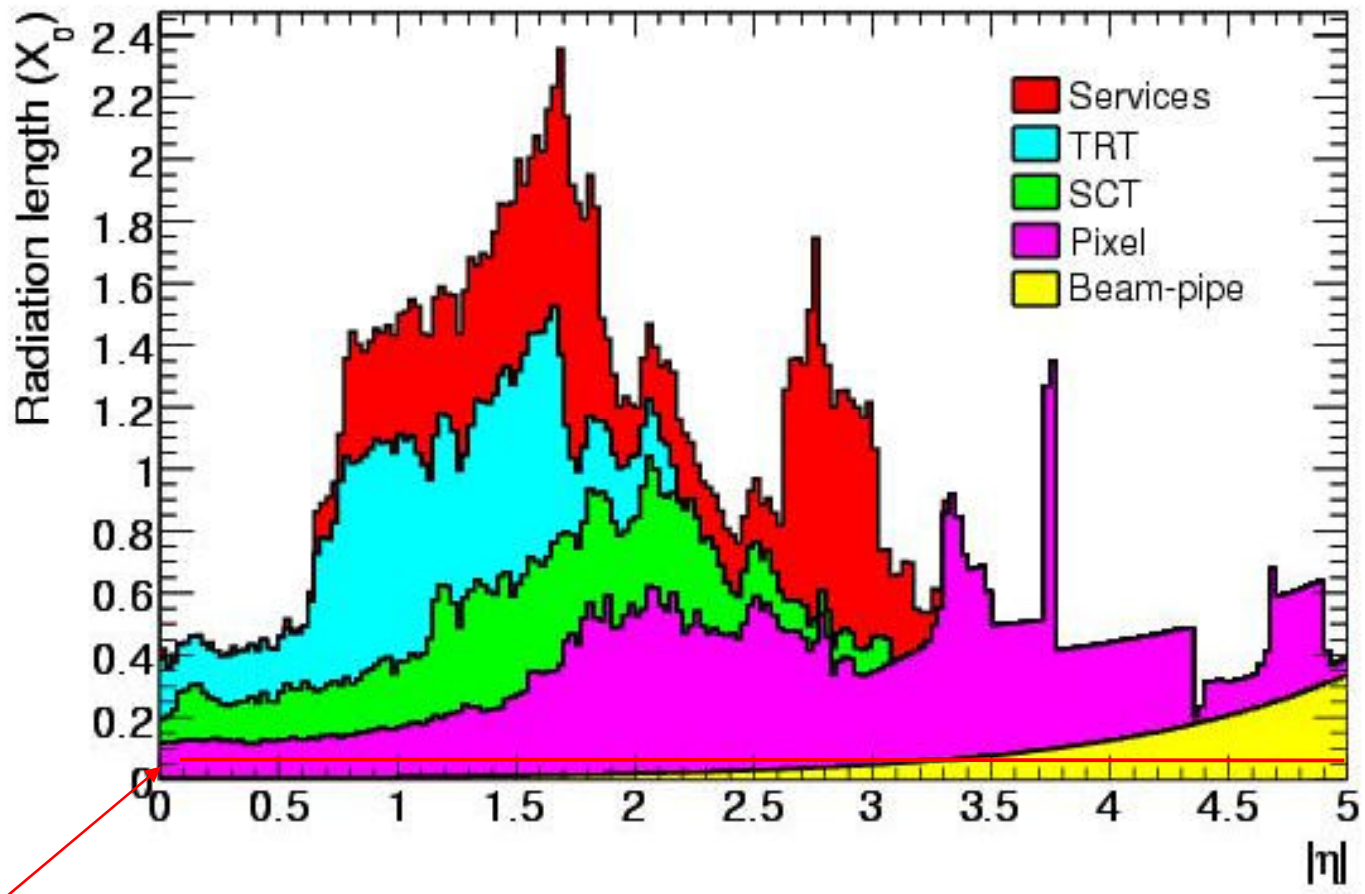

ATLAS tracking system

10% X_0 , a frequently-suggested goal for the LC tracking system. We hope for <1% (VXD) plus 2% (inner timing, if essential) plus 3% (main tracker) ie 4-6% total, disregarding outer timing layer



- Some of these assertions are currently defended only at back-of-envelope level, but they are based largely on experience with, and recent developments in, monolithic pixel architectures
- Obvious concerns:
 - 30 Gpixels for tracking layers. **'No problem'**, given progress in astronomy etc
 - 2.4 Gpixels for timing layers. **'No problem'** within next 10 years, given intensive development of inexpensive interconnect techniques (Petra Riedler)
 - For tracking layers, require excellent charge collection with large monolithic pixels, and good noise performance from large area devices, due to small signals from thin active layers. **'No problem'**, with charge-coupled CMOS pixel technology
 - Quality of track reconstruction, given ~7000 out-of-time tracks per train. **'No problem'**, given well-defined starting point for each on-time track. Pixel systems are better at this than is often realised – the powerful combination of high precision space points and minimal material allows extremely efficient track linking, and suppression of fake tracks (very hand-waving at present; needs simulation)
- General principle, established in ACCMOR and SLD vertex detectors – **fine granularity can to a great extent compensate for coarser timing. Precision time stamping costs power, hence layer thickness, fine granularity does not**

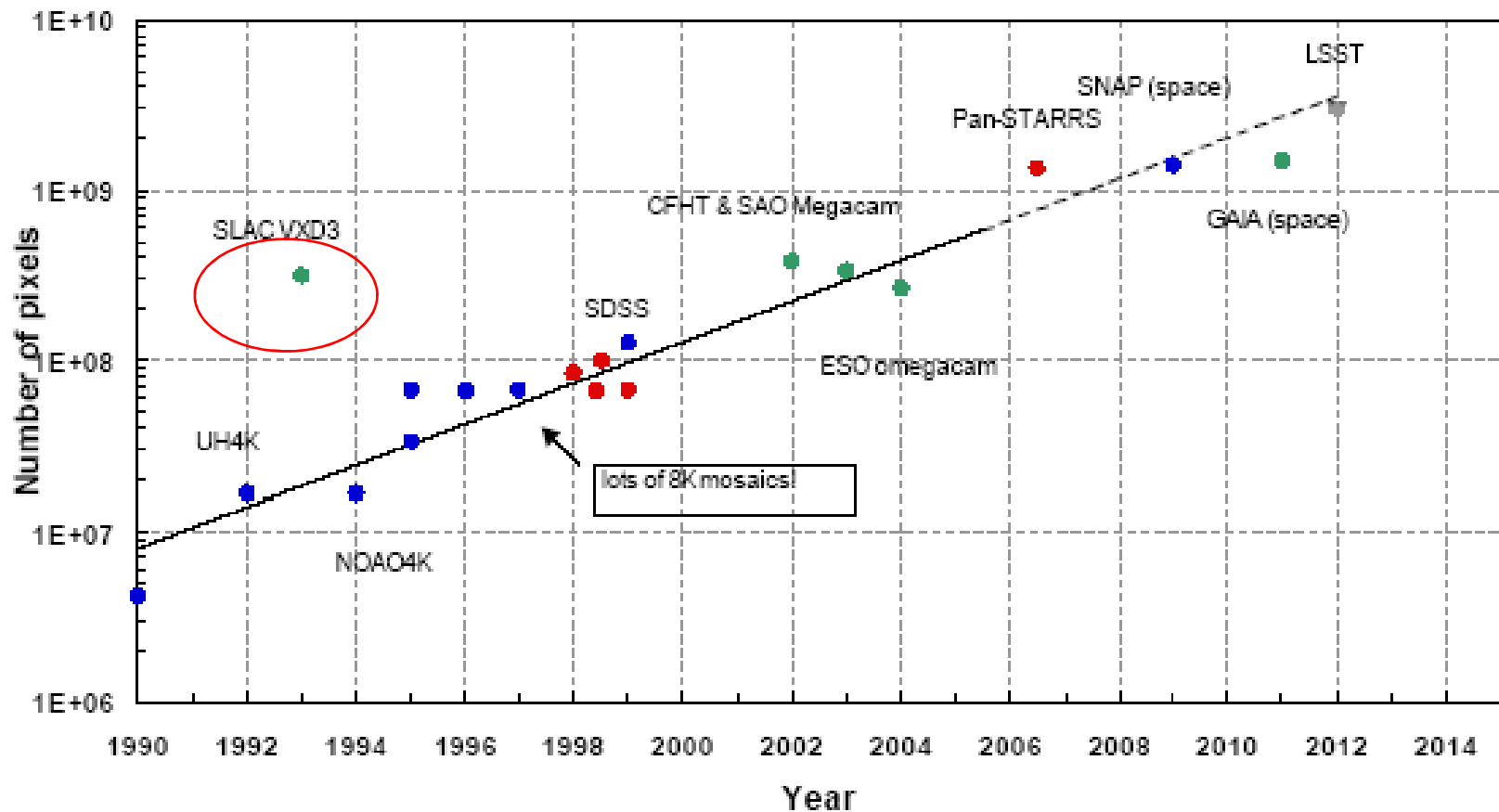
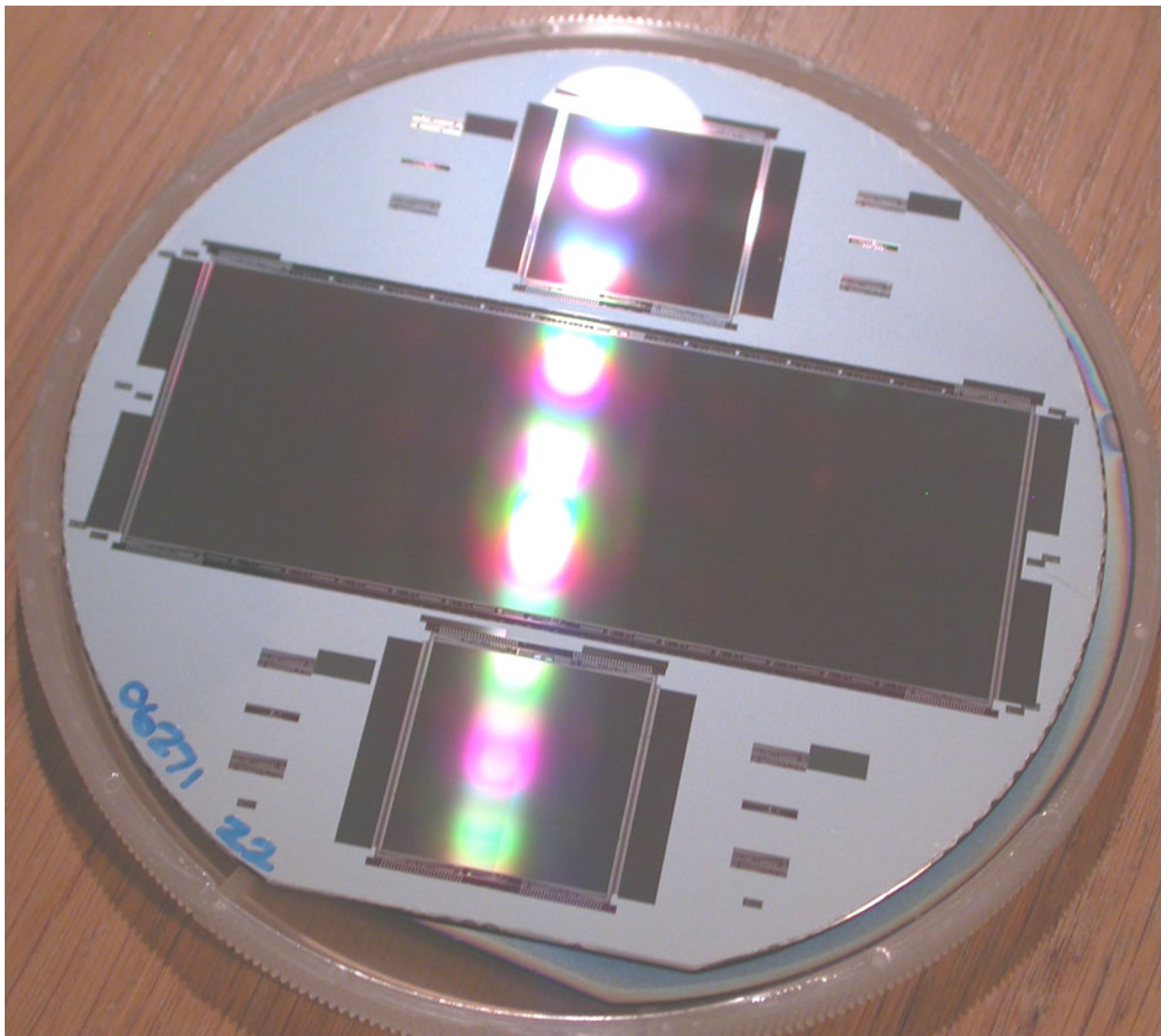

Illustration of focal plane sizes, from Luppino/Burke 'Moore's' law

Focal plane size doubles every 2.5 years

From: Burke, Jordan, Vu, SDW Taormina 2005



e2V technologies
6 inch wafer (CCDs)

(We are thinking of
8x8 cm² charge-
coupled CMOS
pixels, a **monolithic**
high-yielding
process)

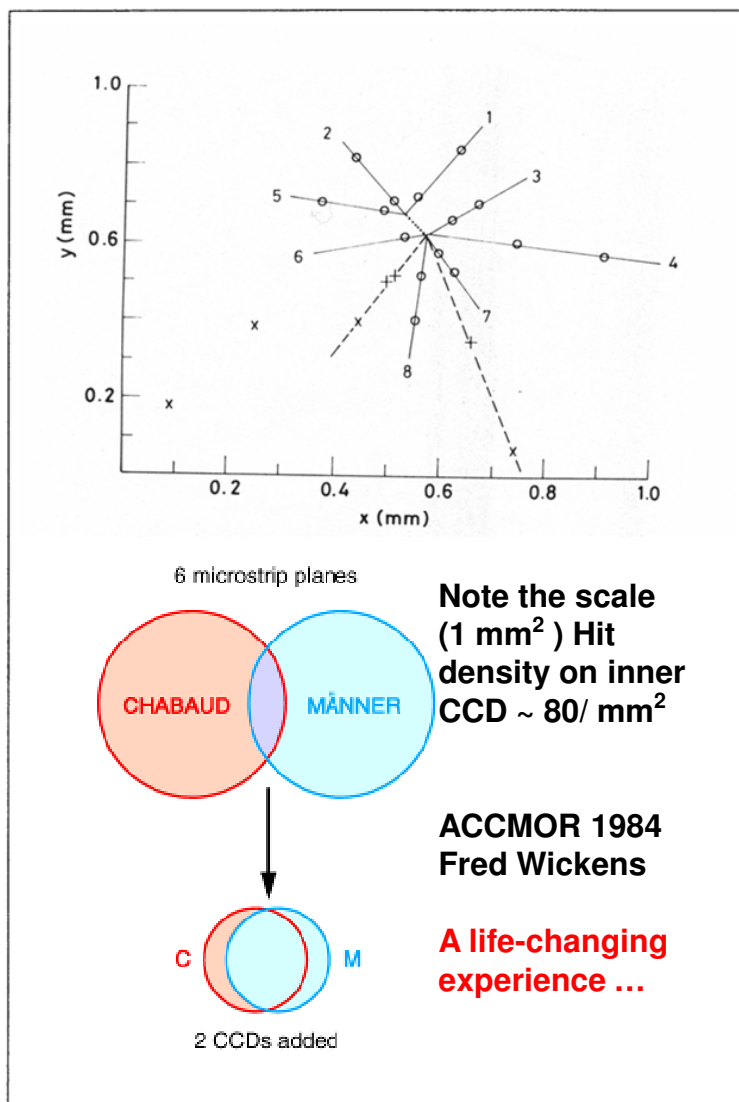

- The ACCMOR collaboration provided the first demonstration of the capabilities of pixel-based tracking detectors, and this was developed in SLD
- For LC vertexing, there is no debate, since the Hawaii workshop in 1993.
- For LC tracking, studies began two years ago, but progress has been slow and the SPT is not yet in anybody's baseline. Progress reported at ILC workshops: Sendai, March 2008, Warsaw, June 2008 and Chicago, November 2008
- Meanwhile, for the rest of the world of digital cameras, scientific imaging, etc, the pace of progress is remarkable ...

Nobel Prize for Physics, 2009

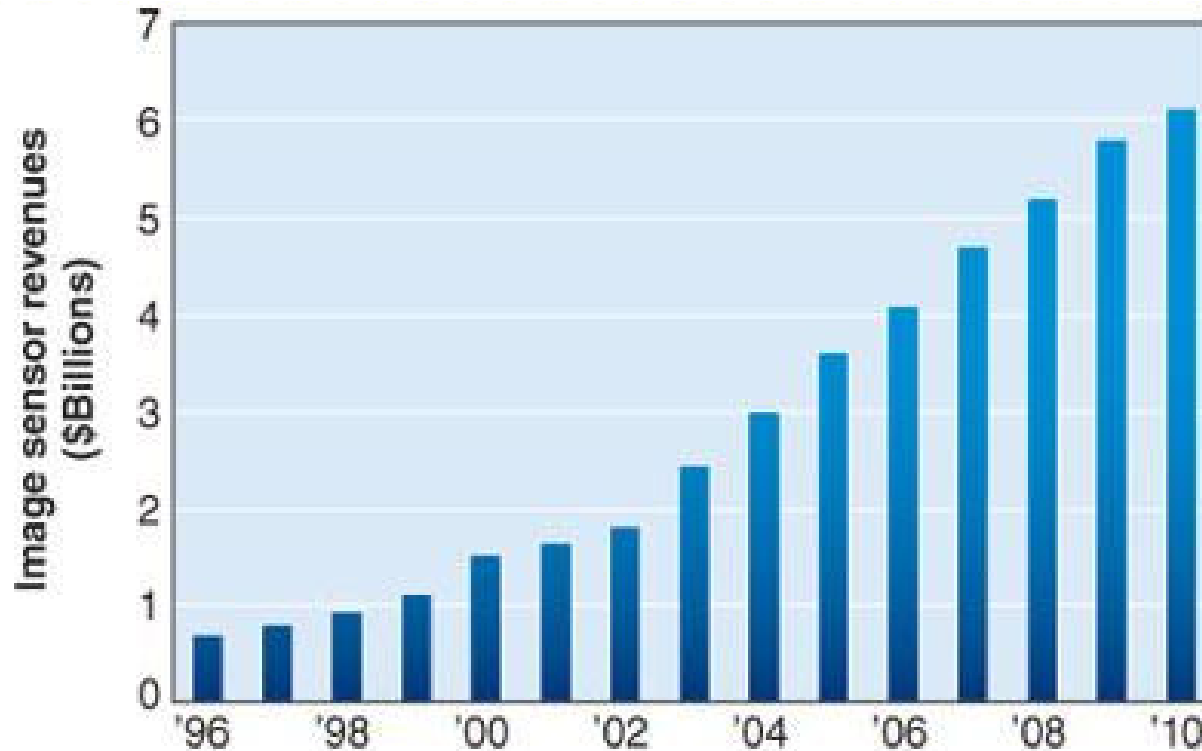

Fibre optics and the CCD: “Taken together, these technologies have had a greater impact on humanity than any others in the last half century” Fred Doyle, CEO of American Institute of Physics

“Optics technologies are exceptionally significant for scientific developments in today’s world. We congratulate **Kao, Boyle and Smith on this much-deserved recognition” Elizabeth Rogan, CEO of the Optical Society of America**



Boyle and Smith having fun at Bell Lab, 1974

Boyle, 2009: At Bell Lab, there were no ‘project proposals’, no ‘deliverables’, no ‘impact statements’, just a bunch of bright people paid to work creatively together. So far, 10 Nobel Prizes have been awarded to Bell Lab, which was long ago shut down.



SPT at CLIC - suggested architecture and track reconstruction procedure

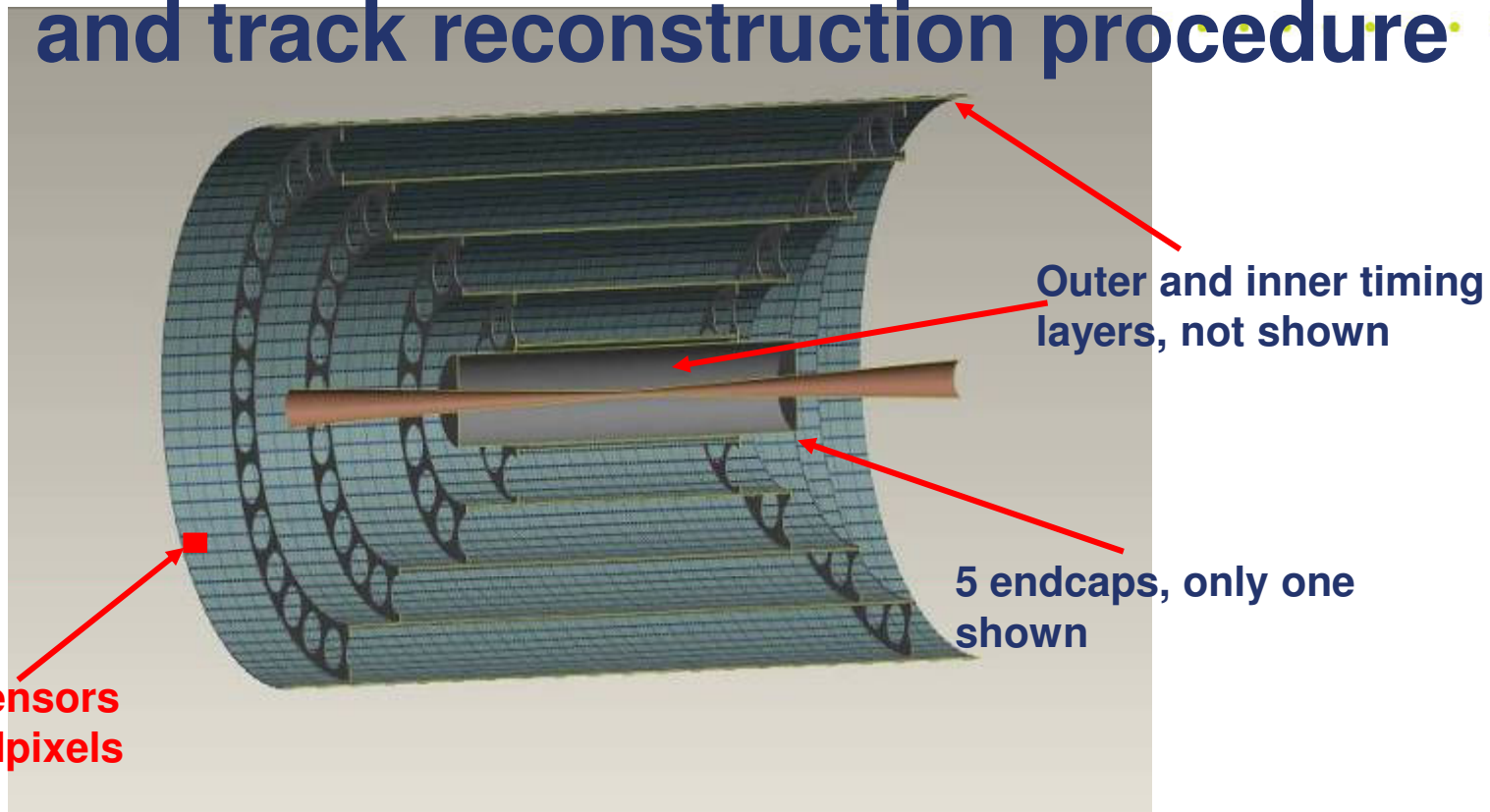

- SiC foam support ladders, linked mechanically to one another along their length
- 5 **closed cylinders** (incl endcaps) will have excellent mechanical stability. Very low power and little cabling, due to continuous readout between trains (as for ISIS vertex option)
- $\sim 0.6\%$ X_0 per layer, 3.0% X_0 total, over full polar angle range, plus $<1\%$ X_0 from VXD system (goal)
- Additional timing layers, one (double) as an **envelope** for general track finding, and one **between VXD and tracker**, if advantages outweigh disadvantages ...

- In summary, we suggest:
 - 5 tracking layers of 50 μm monolithic pixels, area 81 m^2 , 32.6 Gpixels, 0.6% X_0 per layer
 - 1 double timing layer (outer) of 150 μm hybrid pixels, area 76 m^2 , 2.4 Gpixels, 2% X_0 per layer. Timing resolution 1-10 ns, depending on power/cooling considerations (NA 62 an extreme demonstrator)
 - 1 timing layer (inner) of 150 μm hybrid pixels, area 4.3 m^2 , 19 Mpixels, 2% X_0 , **if really needed**
- If we could disregard loopers at polar angles close to 90 degrees, we could omit the inner timing layer. Similar concern in the forward region, where, below 1 Gev/c, might need one or two additional tracking disks, for unambiguous track following
- **Question: what momentum threshold can we set for tracking, to avoid diminishing physics at the 3 TeV collider?** Reducing this threshold would increase somewhat the material budget, but it isn't dramatic



Backgrounds in silicon tracker

- Thanks to Takashi Maruyama, Norm Graf, John Jaros, Marco Battaglia and Marcel Vos for help with this
- **For ILC at 1 TeV**, Takashi has calculated beamstrahlung-related and 2-photon backgrounds, both charged tracks and photon conversions
- 80% of hits are due to photons emitted from the BEAMCAL region, converting in the material of the tracker
- These photons are mostly of energy 0.1-1 MeV, with a peak at 0.51 MeV from positron annihilation in the BEAMCAL
- Using EGS, Takashi studied the conversion process in the detector, mostly Compton scattered electrons - tiny loopers which generate typically 1-10 hits in a tracker layer
- **For CLIC at 3 TeV**, 2-photon background dominates (Marco), ~7000 tracks per train, forward peaked. These produce very low occupancy in our pixel tracker. Need excellent rejection capability from the timing layers. Problem of **hit ambiguity** in tracking layers due to background appears to be at a low level, except for low momentum tracks ($< \sim 1$ GeV/c) detected in the endcap system



A possible track-finding strategy

- Start with **timing layer 5** (double, to provide a reasonable initial vector) and extrapolate to **tracker layer 5** and (for redundancy) **layer 4**, with a loose IP constraint
- Now extrapolate tracks of increasingly well-defined momentum to layers 3, 2, 1 with precision limited mainly by multiple scattering, and end up with **well below one fake track per event** (back of envelope, for ILC case)
- At a certain level, the multiple-scattering-limited search ellipse from layer N to layer N-1 may find two hit candidates. Take the closest hit to the current helix, and possibly revise at end of the hit-assignment process
- This procedure will deteriorate for low momentum tracks in the forward region, below a radius of ~ 70 cm. Options:
 - Impose a momentum cutoff ~ 1 GeV/c *
 - Introduce additional tracking layers, more closely spaced
- K-shorts and lambdas are accommodated, given the vector from the two outer timing layers (Garfield approach) and loopers with θ_p close to 90 degrees are accommodated by using the inner timing layer. But do we need the latter? *
- * 1 GeV cutoff may be OK even for **vertex charge**, for TeV-scale physics. Previous study was for 50 GeV jets. Certainly OK for Sabine's processes *even at 500 GeV collision energy*

The challenge in the fwd region

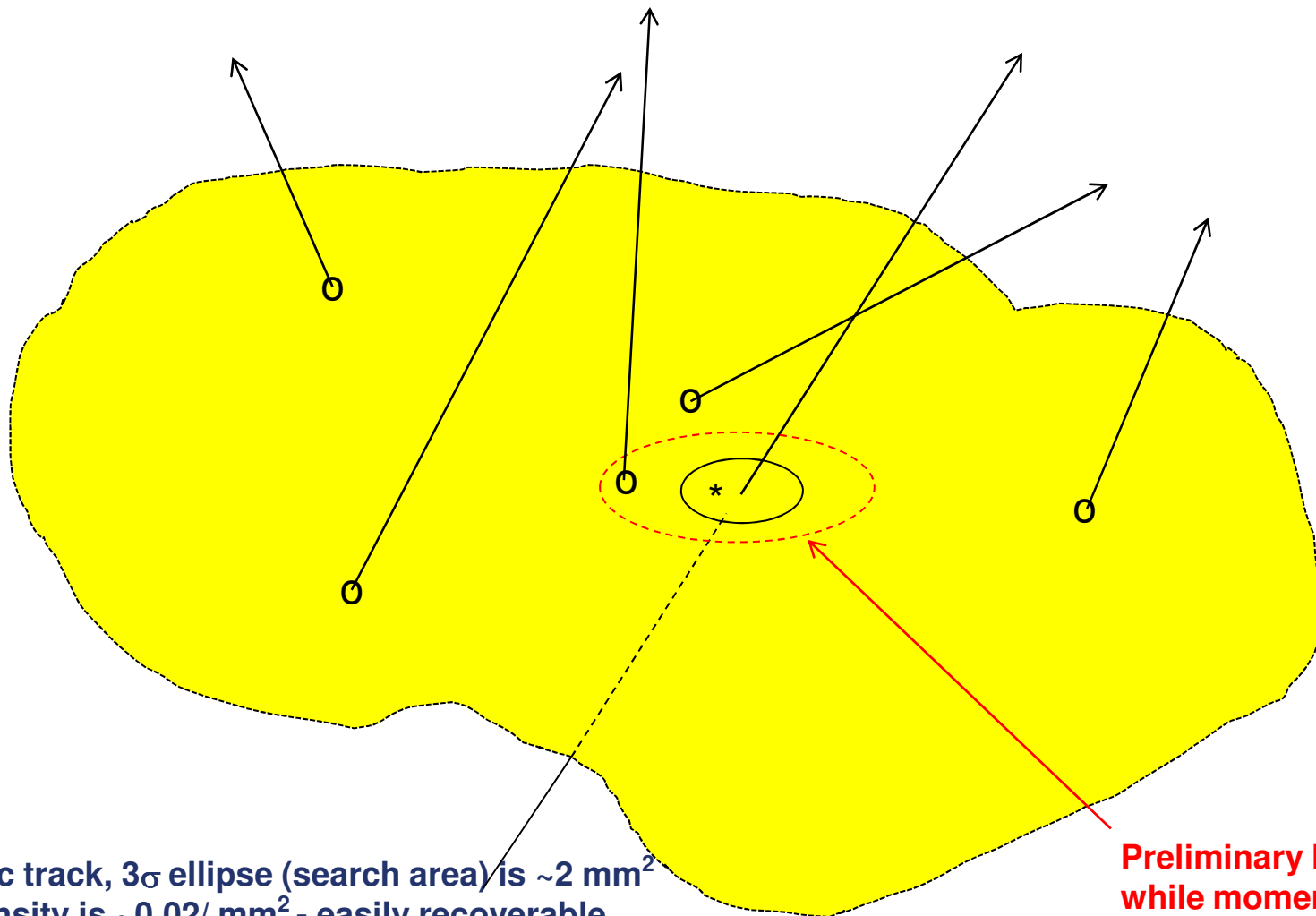

**Preliminary linking,
while momentum is
still poorly defined**

For 1 GeV/c track, 3σ ellipse (search area) is $\sim 2 \text{ mm}^2$
 Bgd hit density is $\sim 0.02 / \text{mm}^2$ - easily recoverable
But search area increases quadratically as momentum falls
 Could compensate, up to a point, with additional tracking disks
 Tend to lose inner-layer hits for low-mom trks, but that's OK



Monolithic pixels: historical/technical overview

Charge-coupled devices (CCDs)

devices up to wafer-scale, wide range of pixel sizes, low dark current* and excellent noise performance, **slow readout**

Wide range of scientific applications

CMOS active pixels (MAPS)

3T pixels restricted to small pixel sizes, relatively high dark current* and poor noise performance**, **fast readout**

Limited scientific applications

Charge-coupled CMOS pixels

wide range of pixel sizes, low dark current and excellent noise performance, **fast readout**

Potentially wide range of scientific applications

* 1-10 pA/cm² (CCD)
cf 200-500 pA/cm²
(3T CMOS)

** frame-rate CDS,
severe problems for
large chips

Omitted: DEPFET, which is an MPI Halbleiterlabor in-house charge-coupled **non-CMOS** architecture with special properties and wide scientific applications



From CCDs to charge-coupled CMOS pixels

$$V_G = 0$$

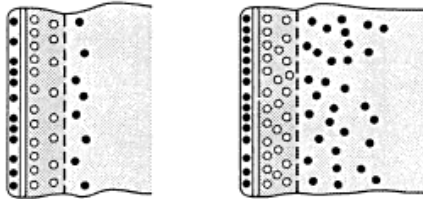

$$(a) V_C = 3 \text{ V}$$

$$(b) V_C = 8 \text{ V}$$
$$x_D = 6 \mu\text{m}$$

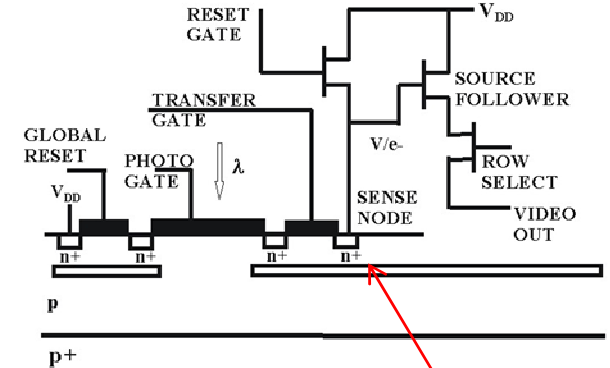
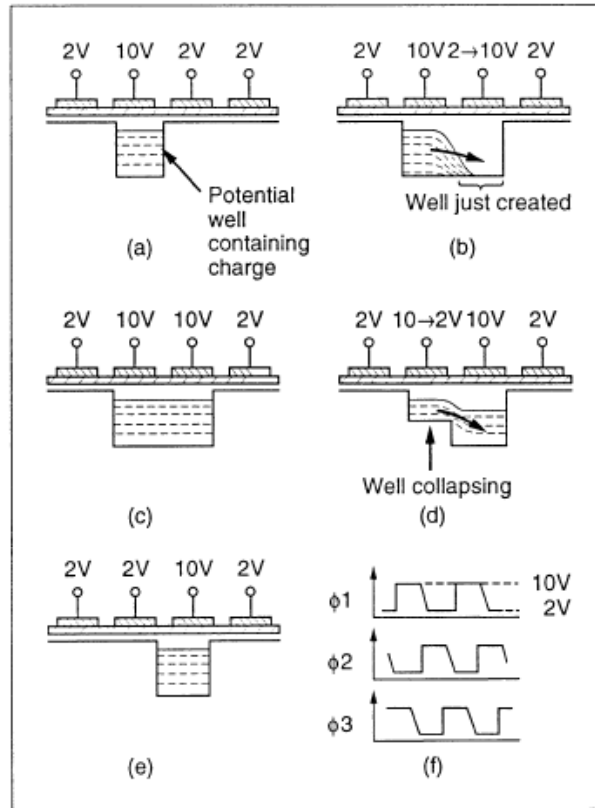
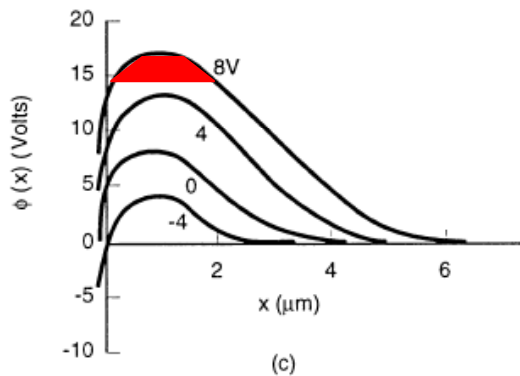

Janesick 2002

6T PHOTO GATE

p+ shielding implant

There are several variants, but in all cases, the key features are:

- Collect signal charge on a fully-depletable structure (PG or PPD) having relatively large capacitance. Shield in-pixel electronics with a deep p-implant
- Sense 'baseline' voltage on gate of submicron transistor having minimal capacitance
- Transfer entire signal charge to this gate and sample again, promptly
- The voltage difference is CDS measurement of the signal

- Advantages are obvious, so why has the CMOS pixel community been stuck with 3T pixels for so long?

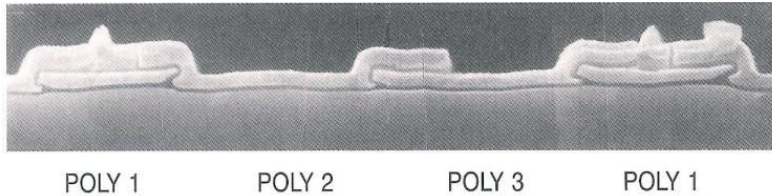

- D Burt, many years ago: ‘The literature is littered with failed attempts ...’ Why was this difficult, and how has the problem been solved?
- Unlike with CCDs, every layer of a CMOS device needs to be precisely **planarised**, or the photolithography for the next layer will be out of focus
- For metal and polysilicon layers, planarisation is achieved by the technique of **damascening**
- With $0.18 \mu\text{m}$ CMOS, an intergate gap of $0.25 \mu\text{m}$ can be achieved with a single poly layer, and this is (just) adequate



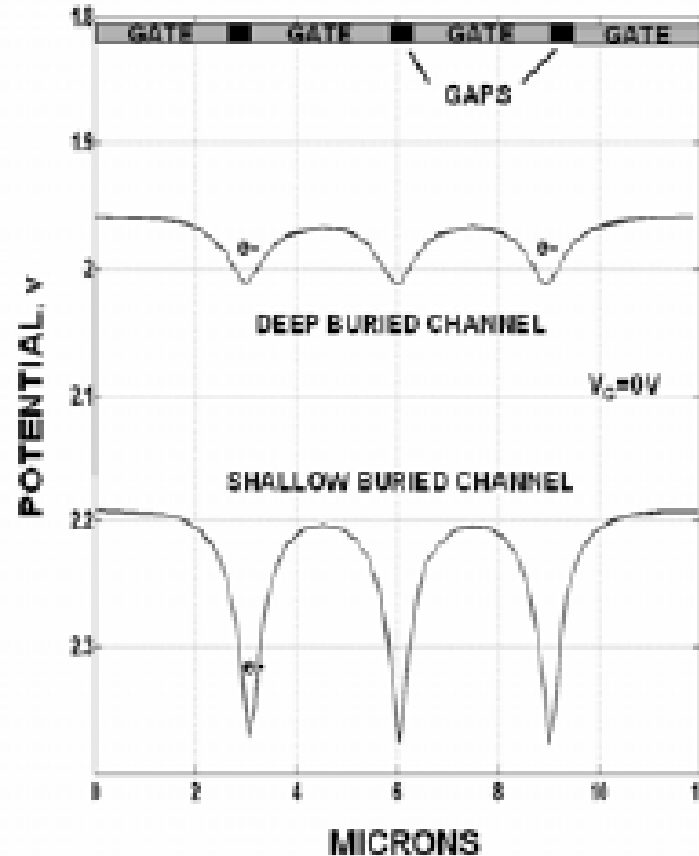

- Massive progress over past 3 years, described in papers by Jim Janesick et al,

Proc SPIE 6276-7 (2006)

Proc SPIE 6690-2 (2007)

Proc SPIE 7439A-6 (2009) (in publication)

- Simulations for BC charge-coupled CMOS (Janesick 2009)

- Similarly encouraging results even for gates as short as 1 μm (Konstantin Stefanov 2007)

- However, short-channel effects and fringing field effects have major effects, often beneficial (George Seabroke 2009)



- Charge-coupled CMOS pixels were first developed for commercial products - high quality cameras, circa 2000
- For scientific applications, there are numerous developments under way:
 - Jim Janesick with Jazz Semiconductor
(note his multi-project wafer Sandbox service)
 - Oxford/RAL with Jazz Semiconductor (ISIS) (surviving remnant of LCFI R&D)
 - James Beletic with Teledyne Imaging Sensors
 - Oregon/Yale with Sarnoff (chronopixels)
 - e2V with Tower Semiconductor
 - Spider Collaboration with 'Foundry A' (Fortis)
 - Andor/Fairchild/PCO (sCMOS) – Press release 15 June, they list 23 scientific application areas, devices to be marketed from next year
 - And probably many others ...
- Numerous design variants, 4TPPD, 5TPPD, 4TPG, 6TPG etc. However, the key in all cases has been to **develop a working charge-transfer capability within the CMOS process**

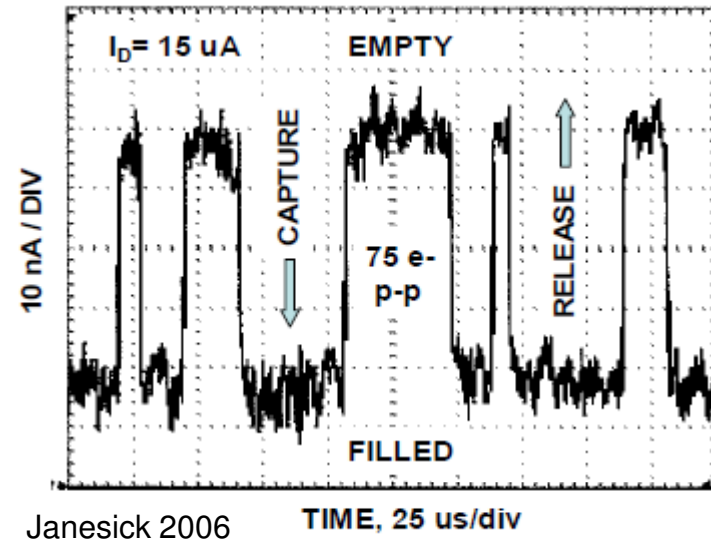
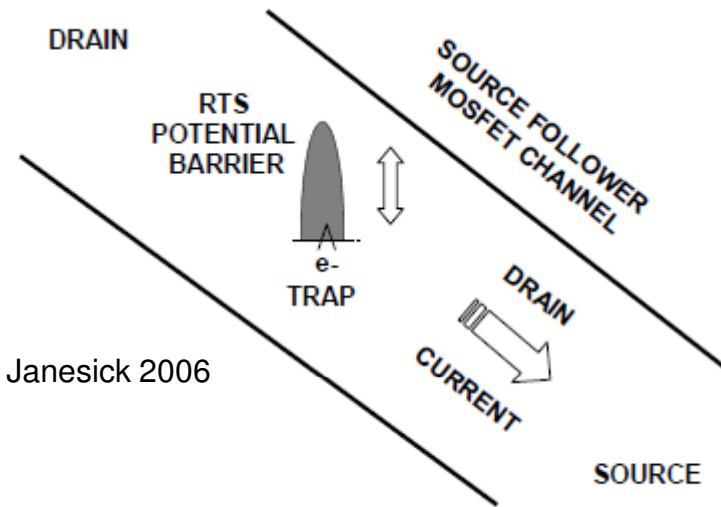

Note: These fluctuations amount to only 0.3% of the drain current

- This is the dominant residual noise source in charge-coupled CMOS pixels
- As with CCDs, transistor noise can be much reduced by using a **buried-channel MOSFET** for the source follower (but not completely eliminated, due to the presence of bulk traps)

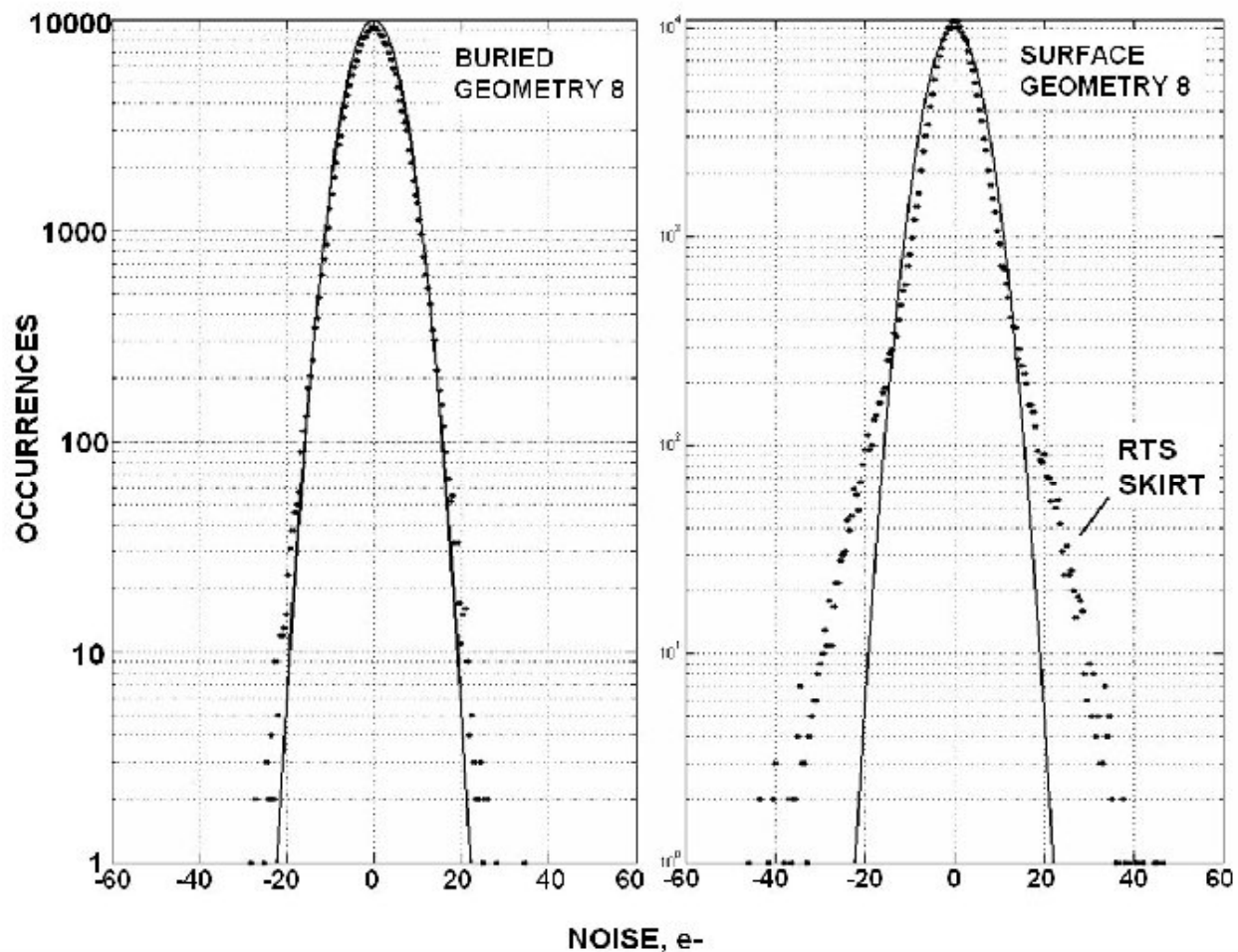

Jim Janesick's latest, week of 5 October, 2009

Silicon Pixel Tracker for CLIC

A possible architecture

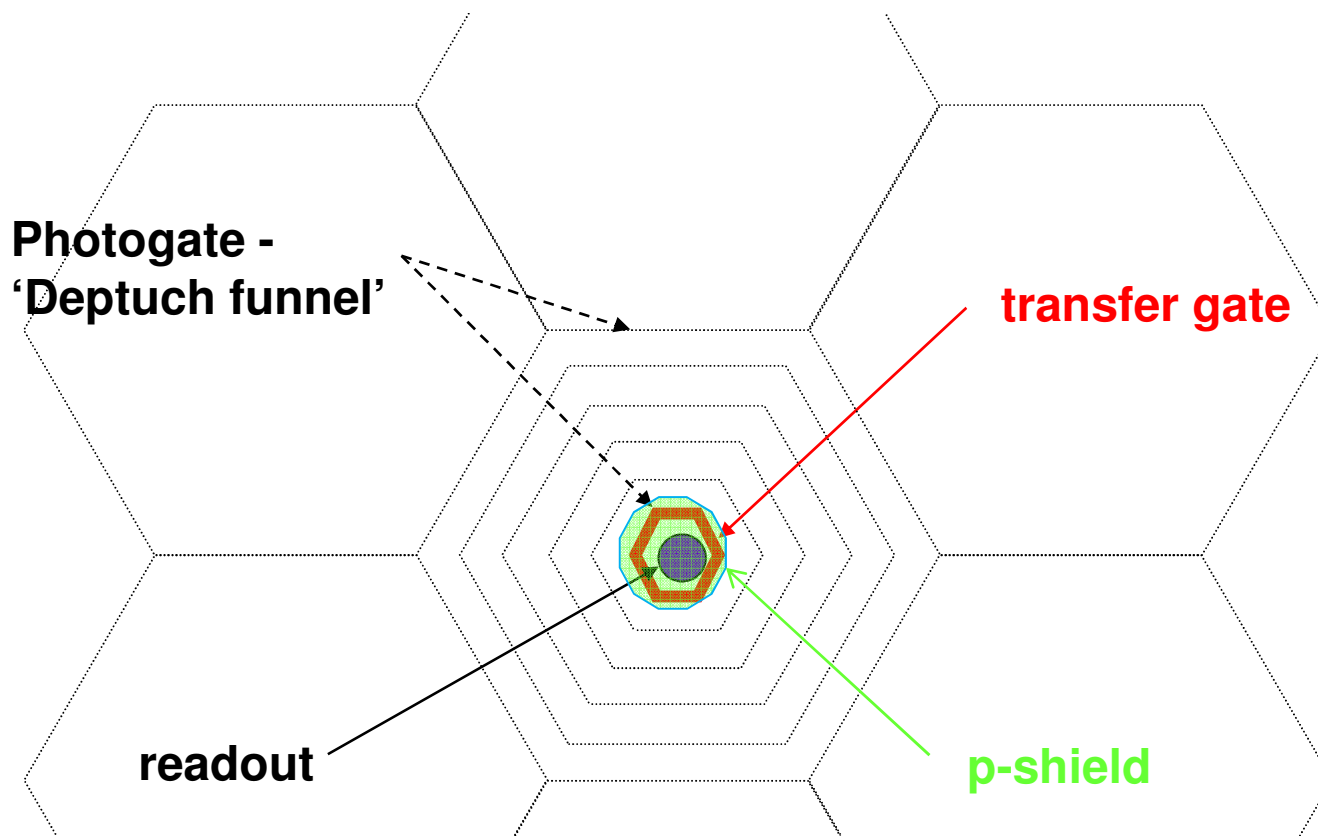

SPT pixels (~50 μm diameter):

- PG preferred over PPD for such large pixels, in which is embedded the ring-shaped transfer gate and 3 tiny transistors, below the p-shield
- 'Deptuch funnel' – need only ~50 mV per stage (and couldn't be much higher, if one uses a 0.18 μm process, limited to 5 V) [**dual gate thickness, 12 nm and 5 V; 4.1 nm and 1.8 V**]. Needed only if an unstructured PG has excessive potential variation.



Conclusions and Outlook

- For visible light and x-ray imaging in astronomy, **monolithic silicon pixel detectors** took over from photographic film in the 1990s
- Their development for particle physics has been slow, but with some exceptions (eg LHC GPDs), these detectors may evolve as the technology of choice for **vertexing and tracking** in many particle physics applications
- We are fortunate to have strong interest and encouragement from the SiLC collaboration – Marcel Vos already made a valuable simulation of our first concept, reported at the LC workshop, in Sendai, March 2008
- SPT could be an attractive option for both CLIC and ILC
- **Main tracker** (30 Gpixels) will be in line with state-of-art for charge-coupled CMOS systems by 2020. Cost of producing monolithic CMOS wafers in volume is low. Dual gate (thickness) CMOS for imaging devices probably has a stable future
- **Timing layers** (two or three, details tbd), assume inexpensive bump-bonding or vertical integration for large chips. Reasonable on this timescale
- **‘The better is the enemy of the good.’** Yes, if the alternatives really are going to be good enough. Furthermore, time is on the side of the better, in this case.
- Very desirable to encourage ‘alternatives’, as with the machine, in order not to be lumbered with an obsolete technology in 2020 or later. Remember SLC vertexing, where they DID encourage and support a novel ‘risky’ alternative, with a good outcome for physics

SLC Experiments Workshop 1982,
just 8 years before start of SLC

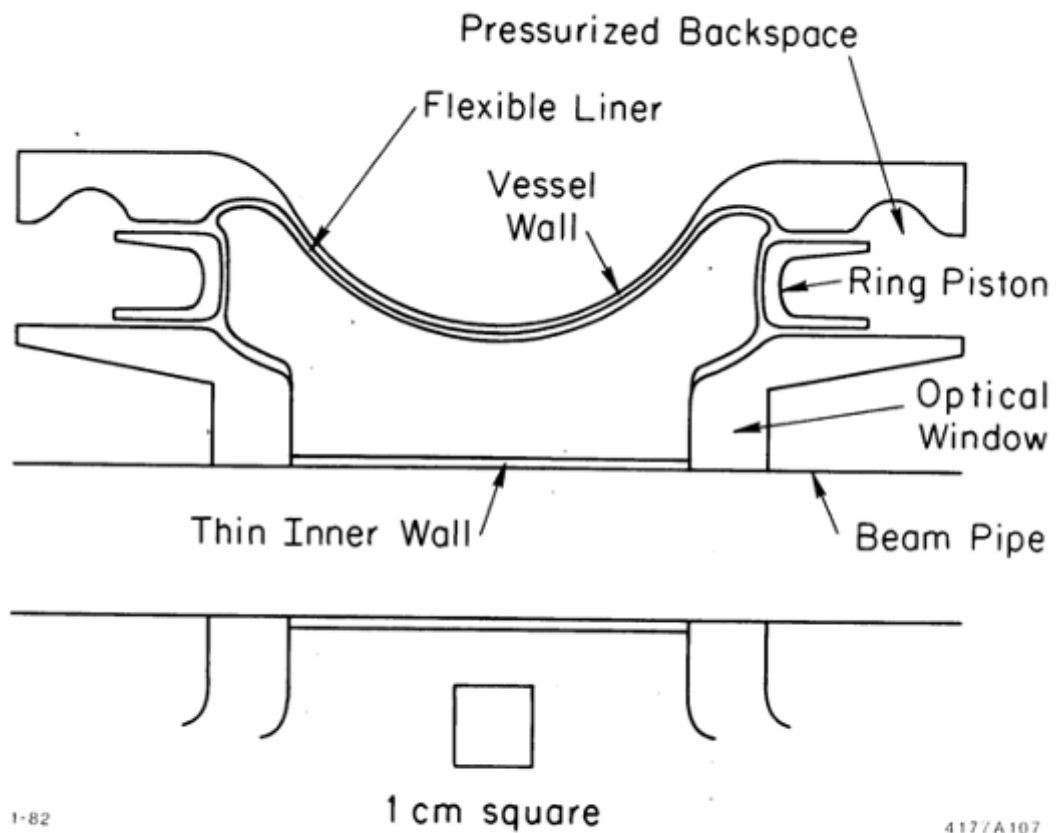
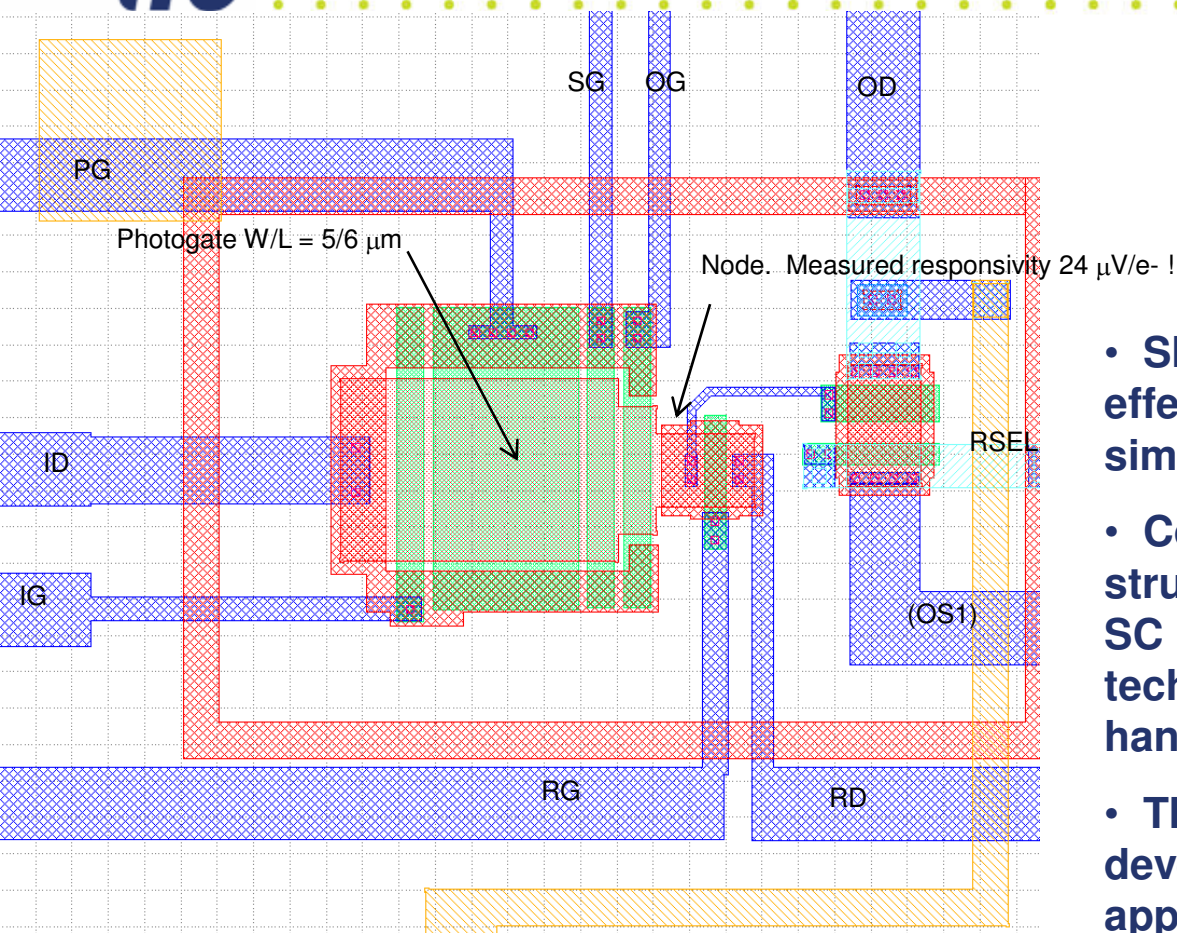

Fig. 7. Conceptual design of a propane bubble chamber vertex detector.

backup

ISIS-2 buried channel test structure



- Short-channel and fringing field effects are large. Former have been simulated, latter still under way ...
- Combining results with this BC structure, and Janesick's 130-element SC register, we can see that the ILC technical requirements are already in hand
- The most urgent need now is to develop the ISIS for near-term SR applications

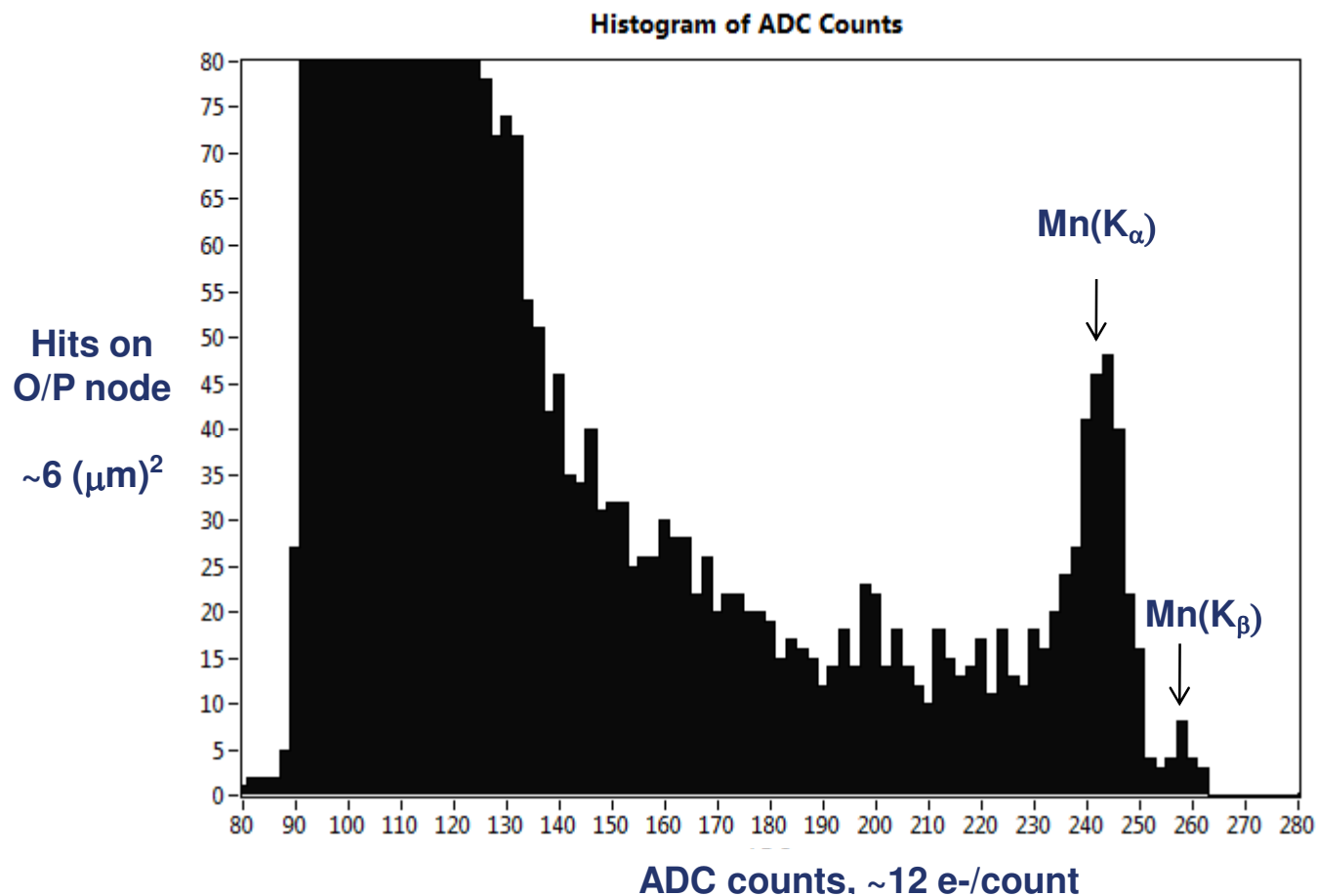

- Shaping time matched to 7 MHz readout
- in 30 years working with fast readout CCDs, we never resolved these peaks
- Promises micron precision in centroid finding for MIPs with approximately normal incidence

Extended Row Filter (ERF) suppresses residual noise and pickup:

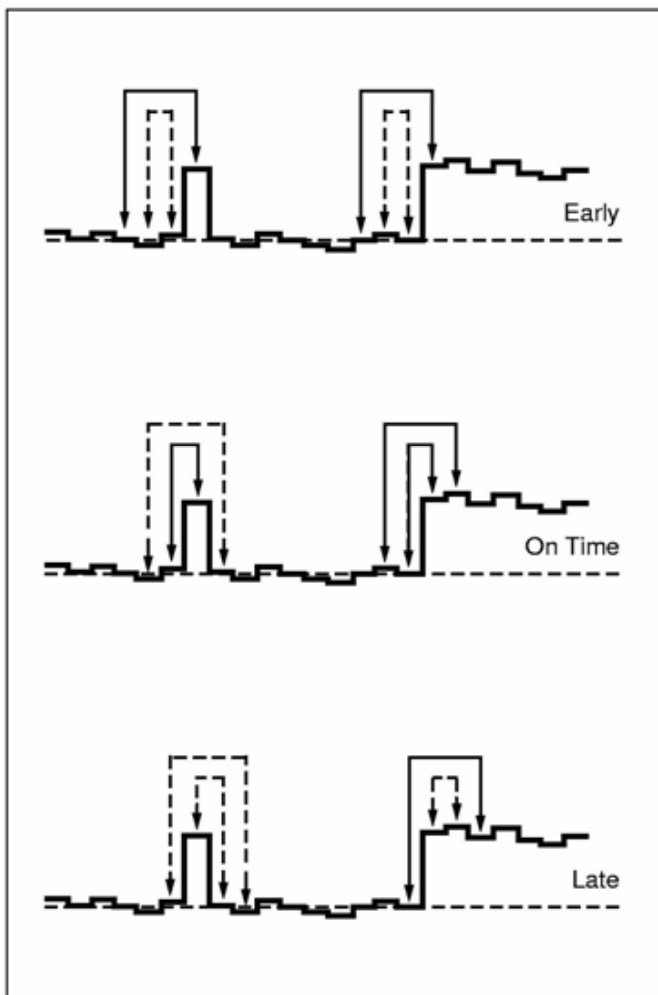

SLD

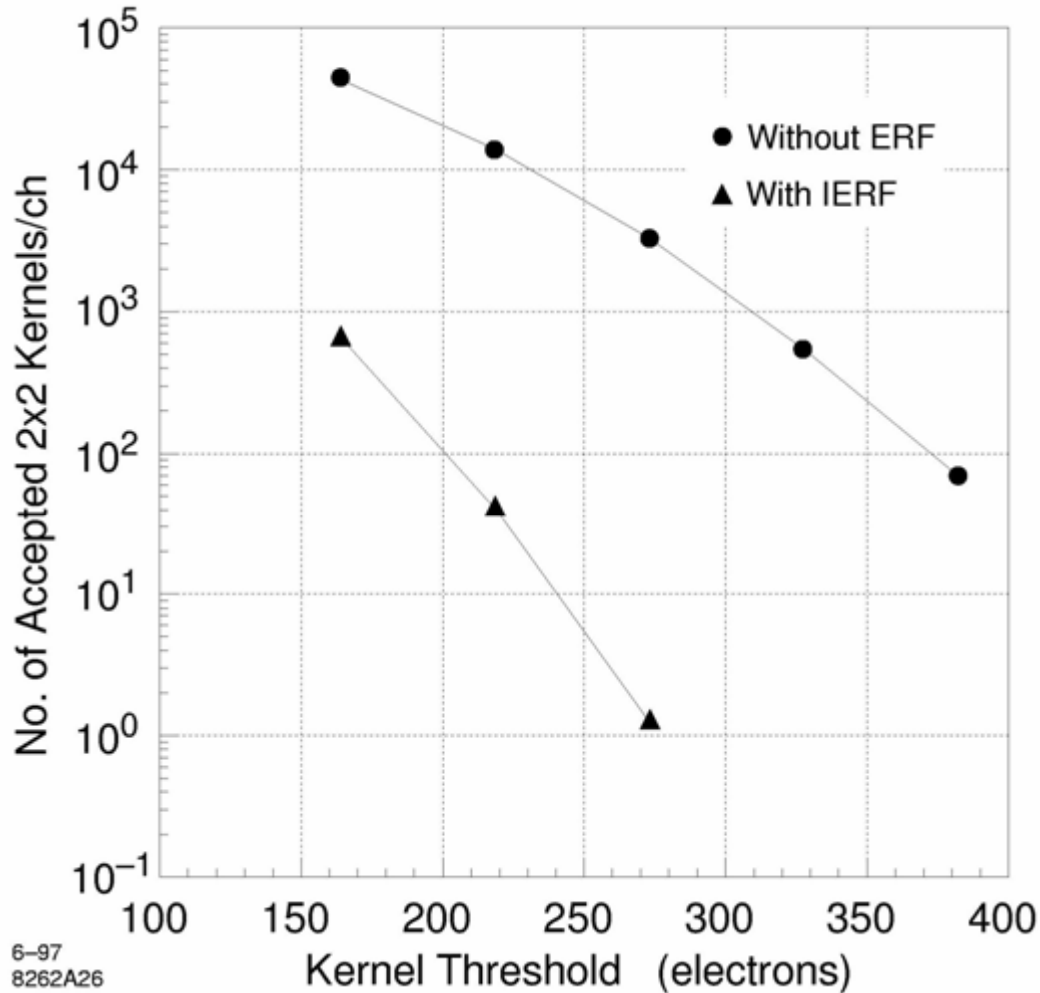

Without ERF, rate of trigger pixels would have deluged the DAQ system

Read out at 5 MHz, during 'quiet' inter-bunch periods of 8 ms duration

Origin of the pickup spikes? We have no idea, but not surprising given the electronic activity, reading out other detectors, etc

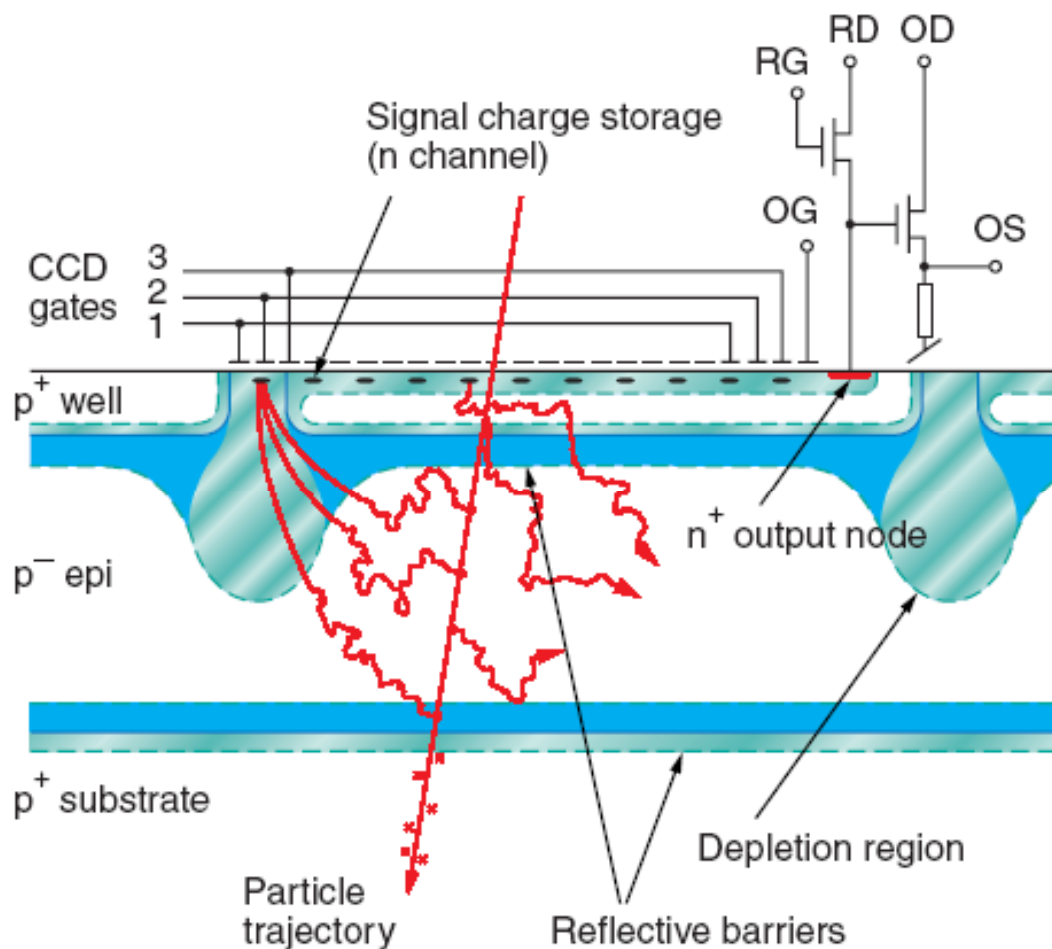

- charge collection to photogate from $\sim 20 \mu\text{m}$ silicon, mainly by diffusion, as in a conventional CCD
- no problems from Lorentz angle
- signal charge shifted into storage register every $50 \mu\text{s}$, to provide required time slicing
- string of signal charges is stored during bunch train in a buried channel, avoiding charge-voltage conversion
- **totally noise-free storage of signal charge**, ready for readout in 200 ms of calm conditions between trains
- ‘The literature is littered with failed attempts ...’

- Total hit density ranges from **2.5/cm²/train** (layer 1 barrel) to 1/10 of that (layer 5 barrel) – **occupancies in SPT are everywhere < 10⁻⁴**
- For the **forward disks**, densities exceed 600/cm²/train, so pixels with short sensitive windows will be needed. Fortunately, area to be covered is small

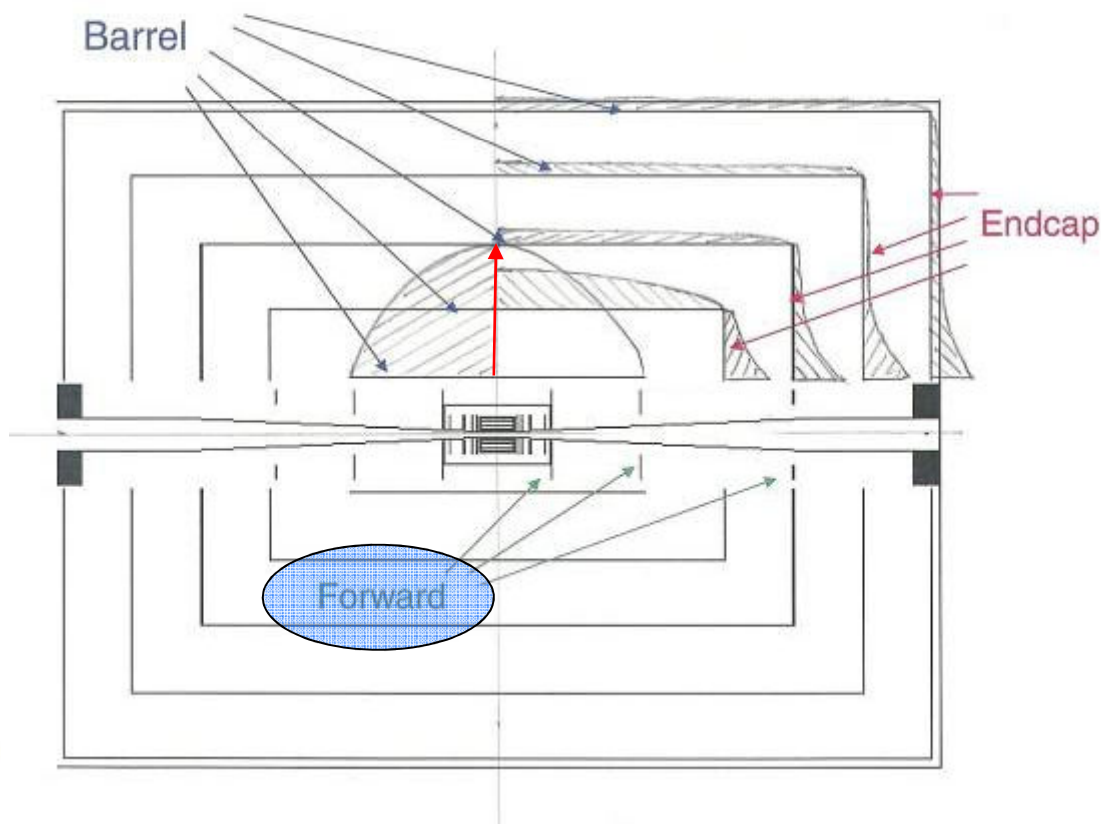

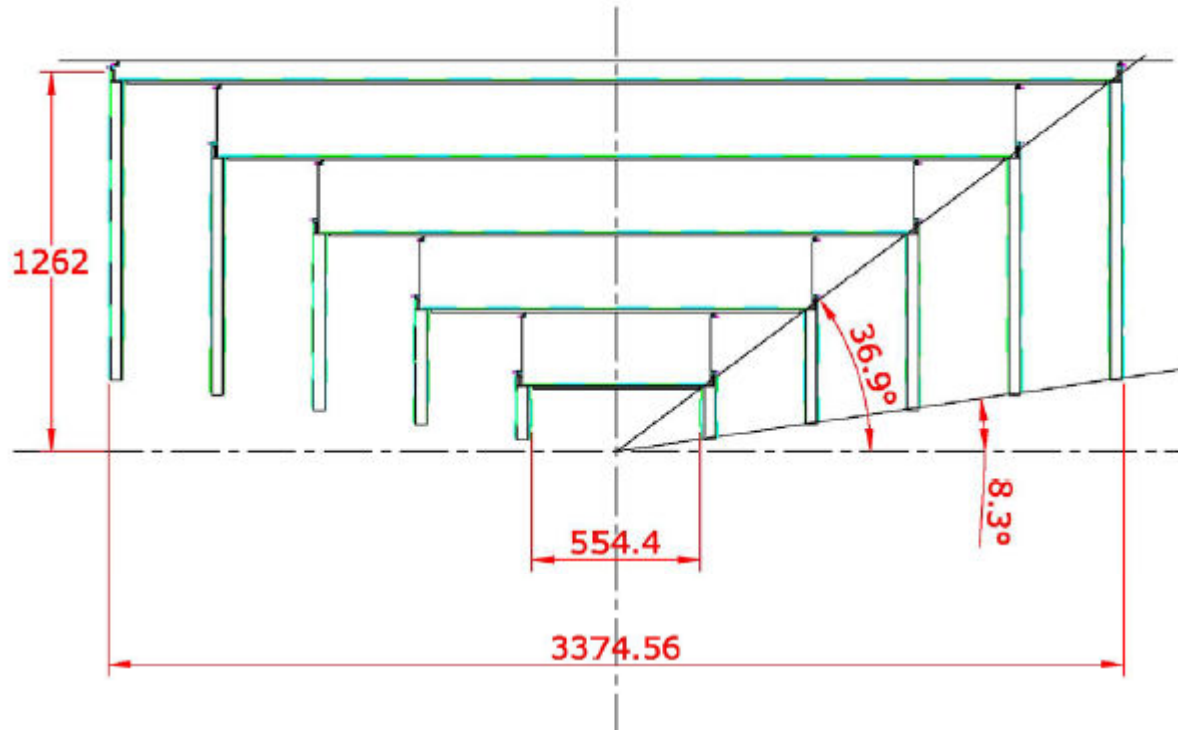

- Barrel and Forward trackers, total area = 70.3 m²
- With 50 μm × 50 μm pixels – **28.1 Gpix system**
- If each chip is 8 cm × 8 cm (2.6 Mpix): 11,000 sensors is total

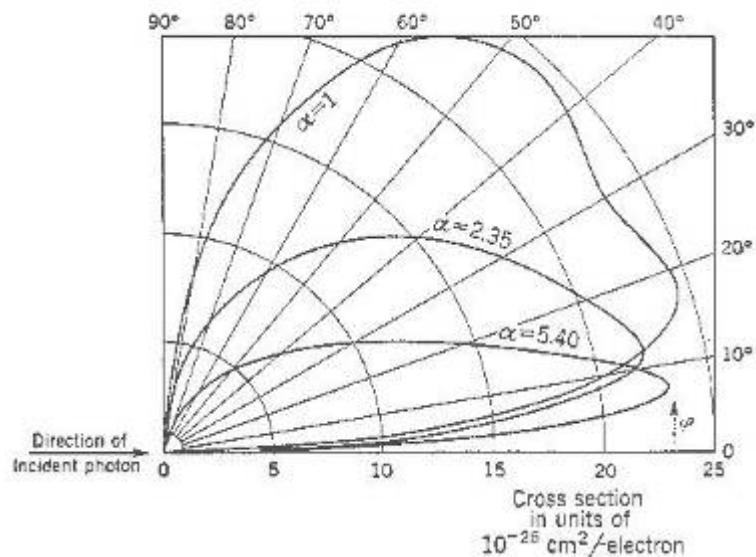

barrel ladder, $r\phi$ view

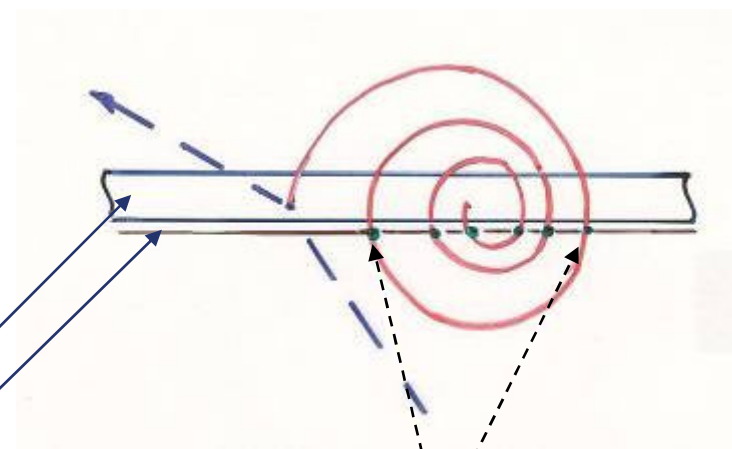

~0.5% X_0 support foam and Cu-kapton

~0.1% X_0 silicon, 30 μm active on inner surface

6 hits, stepped in z , each hit indistinguishable from min-I

End view of 2 barrel ladders ('spiral' geometry)

SiC foam, 4-8%

**

wedge links at ~40 cm intervals

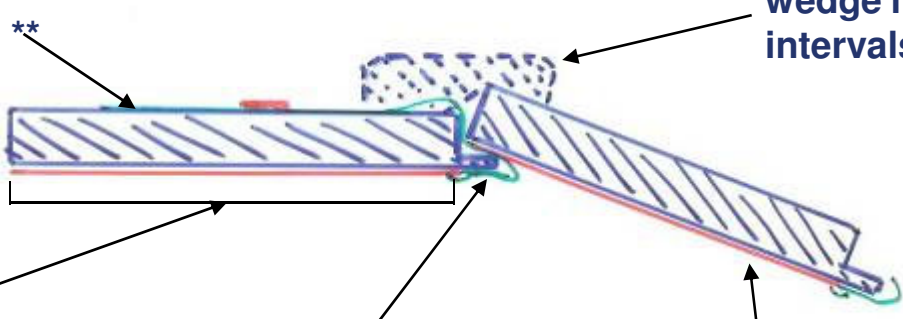

devices will be 2-side buttable, so inactive regions in z will be ~.2 mm (~ 0.2%)

Sensor active width 8 cm, with ~2 mm overlaps in $r\phi$

thin Cu/kapton tab (flexible for stress relief), wire bonds to sensor

Sensor thickness ~100 μm , inner 30 μm active

** single layer Cu/kapton stripline runs length of ladder, double layer in region of tabs (~5 mm wide) which contact each sensor. Single Cu/kapton stripline runs round the end of each barrel, servicing all ladders of that barrel

Bottom line: potential material budget ~0.6% X_0 per layer, but much design and R&D needed to establish mechanical stability, including shape stability wrt push-pull operations (taking advantage of stress-free 3-point kinematic mount)



Silicon Pixel Tracker for ILC (not CLIC) forward region

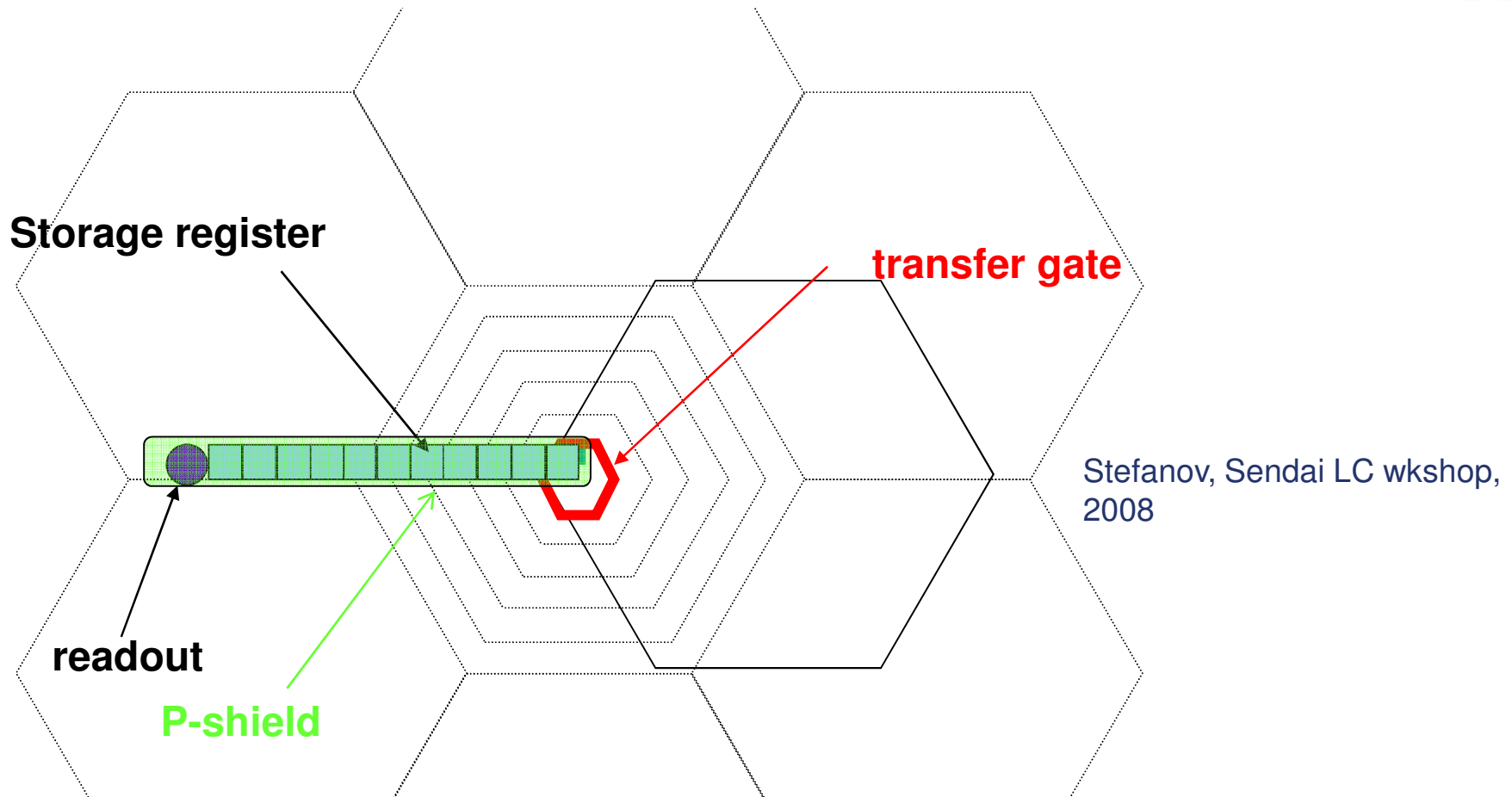

Stefanov, Sendai LC wkshop,
2008

- This ISIS structure (initiated for ILC vertexing) is also of interest as a **fast-frame burst camera for X-ray imaging** at 4th generation light sources (LCLS and XFEL)
- For the x-ray application, fully deplete (currently 30 k Ω -cm epi is available), and back-illuminate: soft X-rays: direct conversion
hard X-rays: via columnar CsI

- Due to the small pixel sizes, even surface channel devices perform well
- Usable up to 1 Mrad ionising radiation (need 2.6 V higher TG amplitude), and this is only the beginning

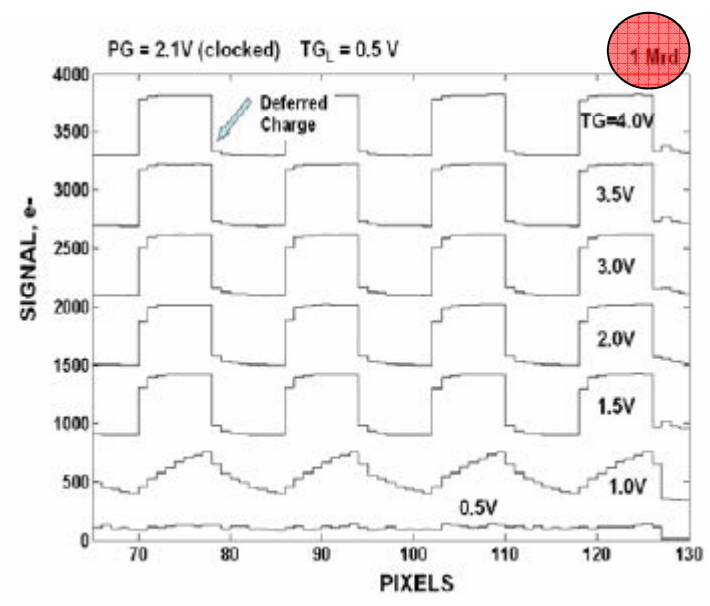
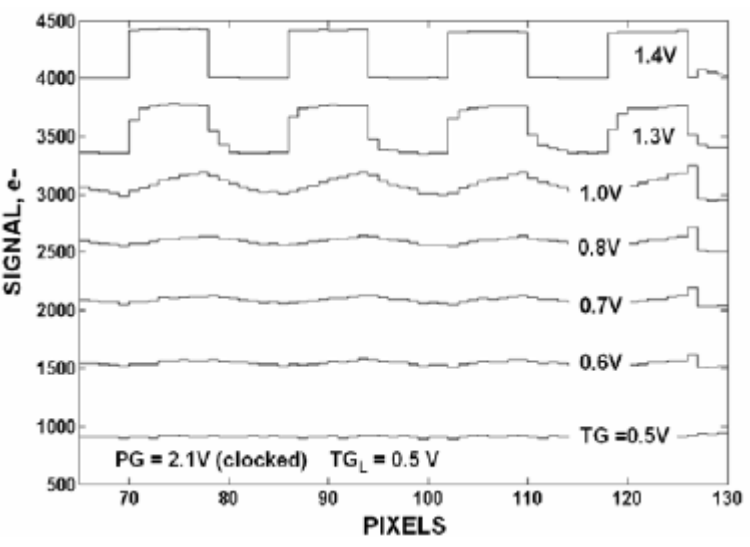

Janesick 2009

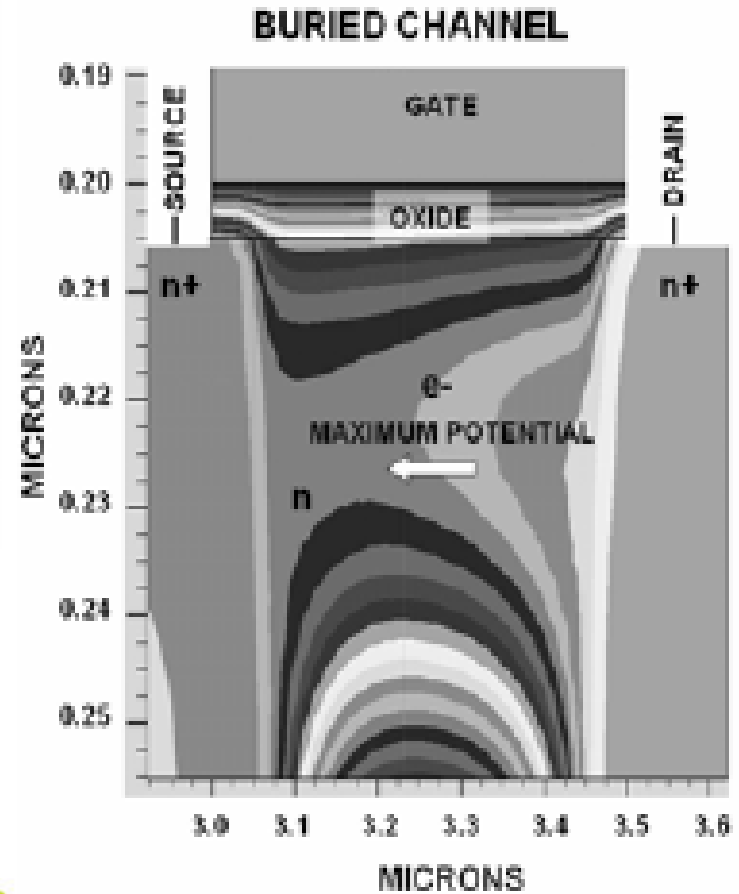
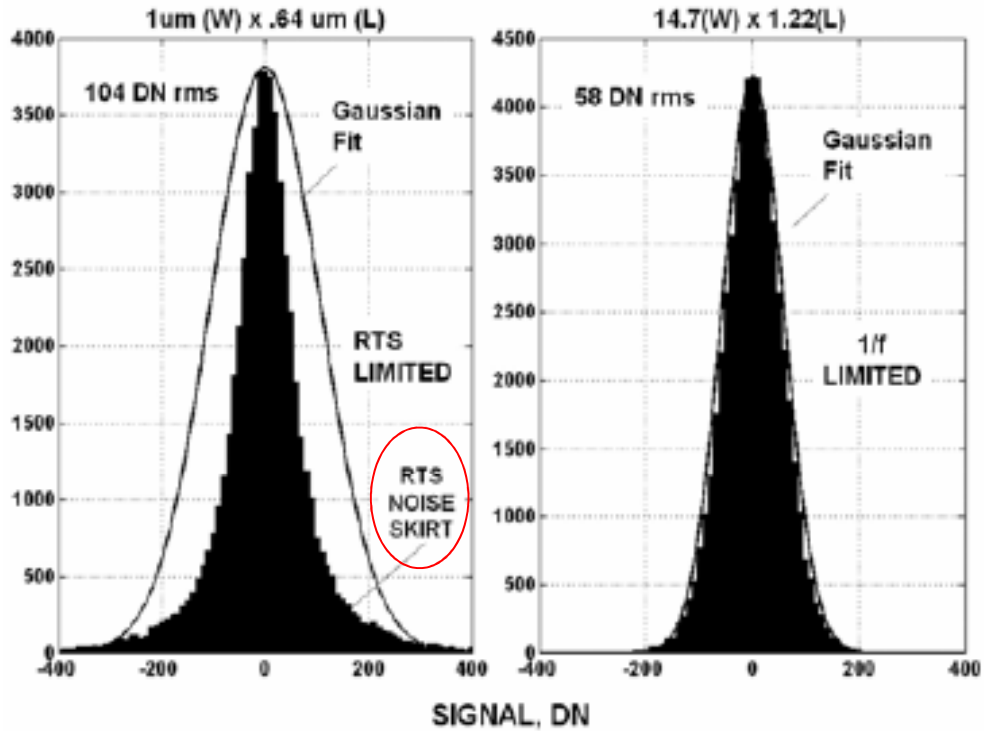

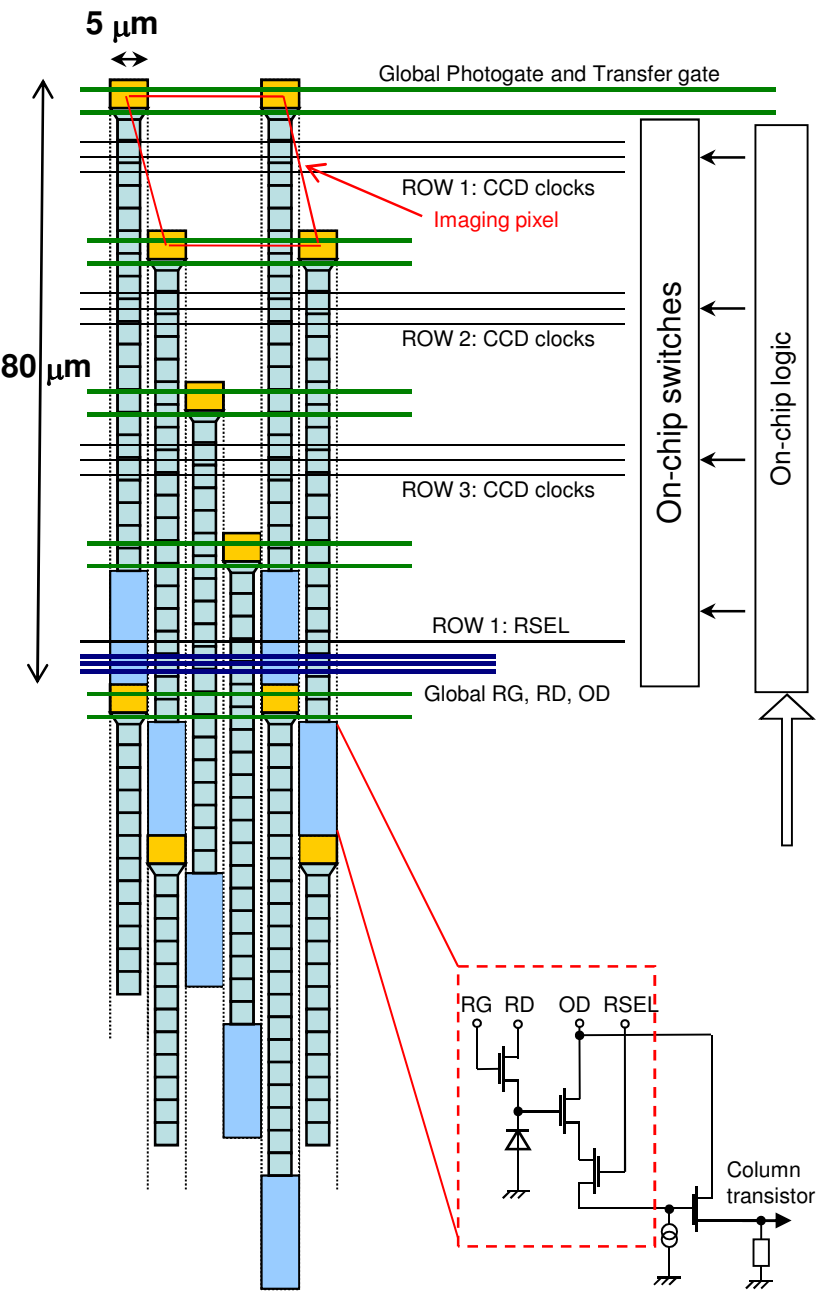

- For ILC vertexing, photogate area is reduced to a minimum, to achieve approximately 20 μm square imaging pixels, much smaller than needed for tracking
- We are already close to this with our ISIS-2 prototypes – we have 10x80 μm storage pixels

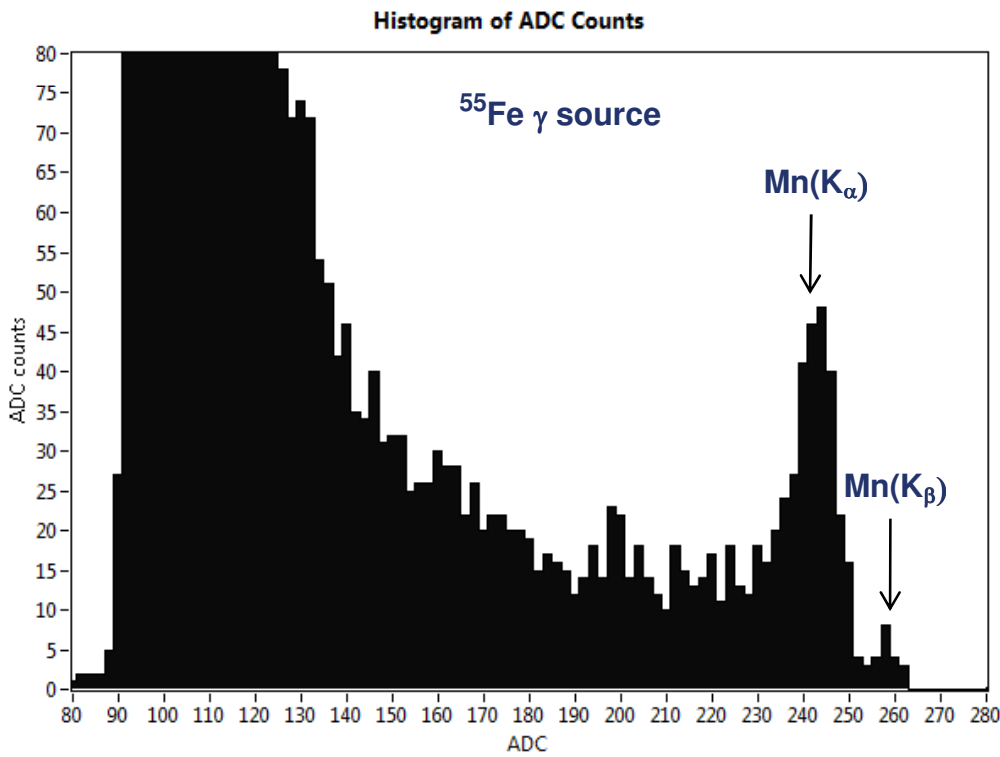

Correlated double sampling (CDS)

[which is possible only for charge-coupled pixels – beware of imitations such as ‘frame-rate’ CDS]

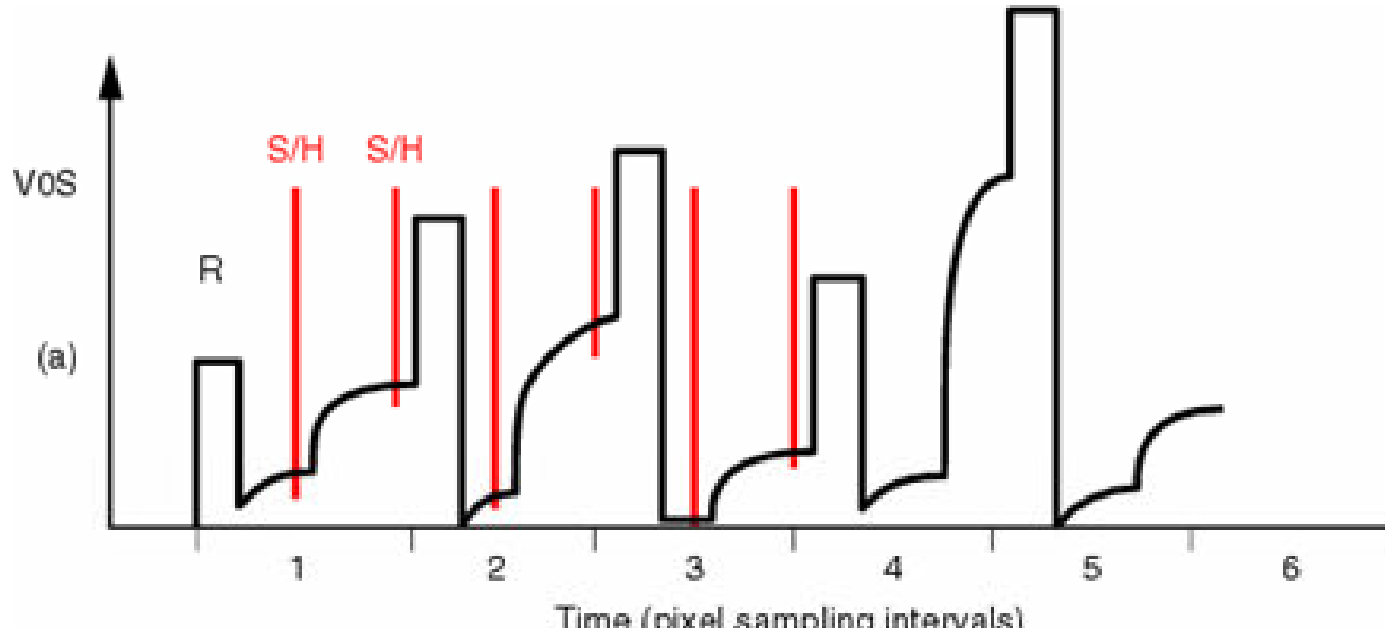

Baseline settles to a different level after each reset, due to kTC noise. Entire signal charge is **transferred** to the output node between the two CDS phases

This eliminates reset noise, fixed-pattern noise, noise from node dark-current, and suppresses pickup – low and high frequency. It enables astronomers to achieve few-electron noise performance with long exposure times, and particle physicists to make efficient trackers with large area devices having $\sim 20 \mu\text{m}$ of active silicon

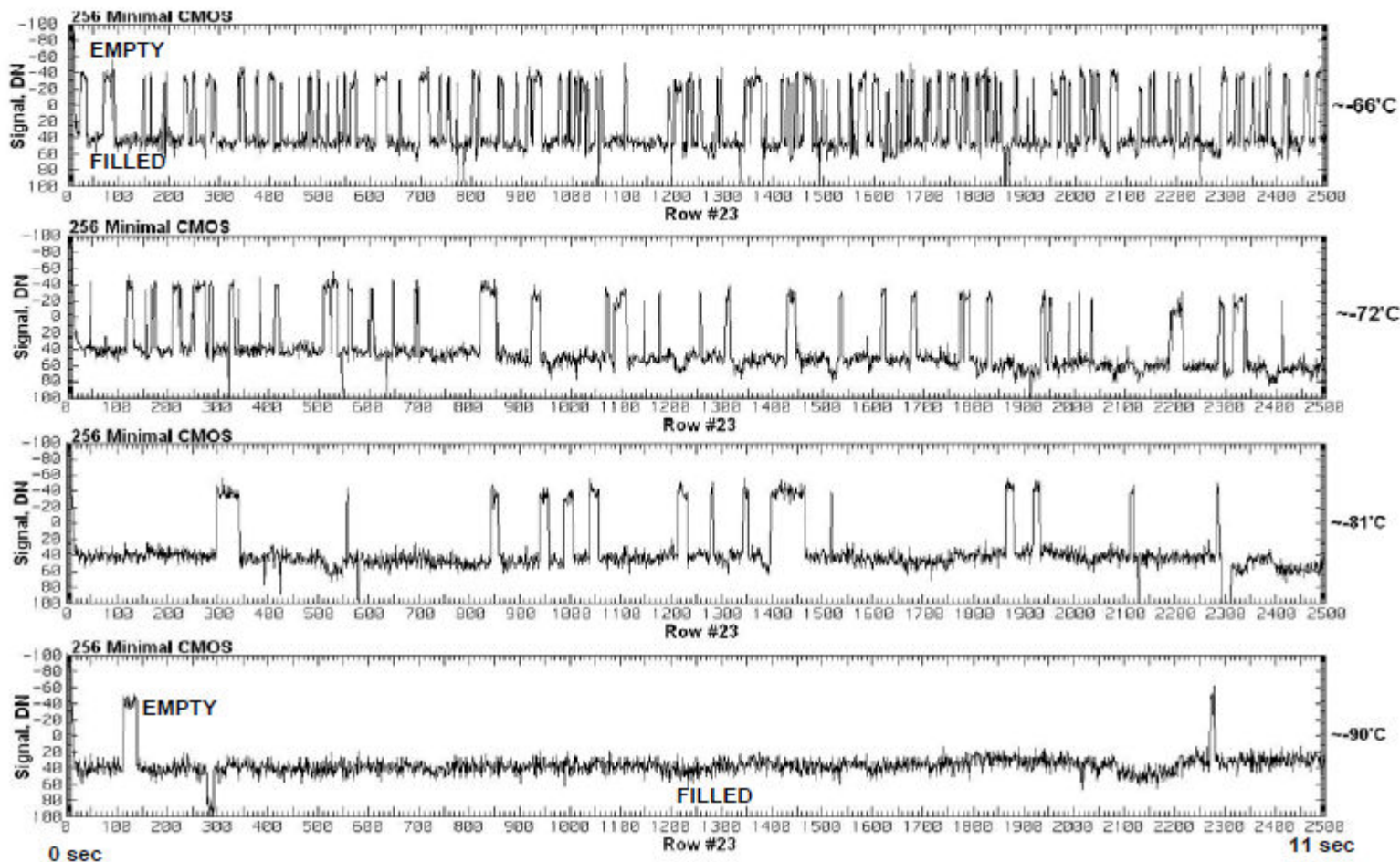

Janesick 2006

Despite this behaviour, there is *nothing* (as regards noise performance) to be gained by cooling!

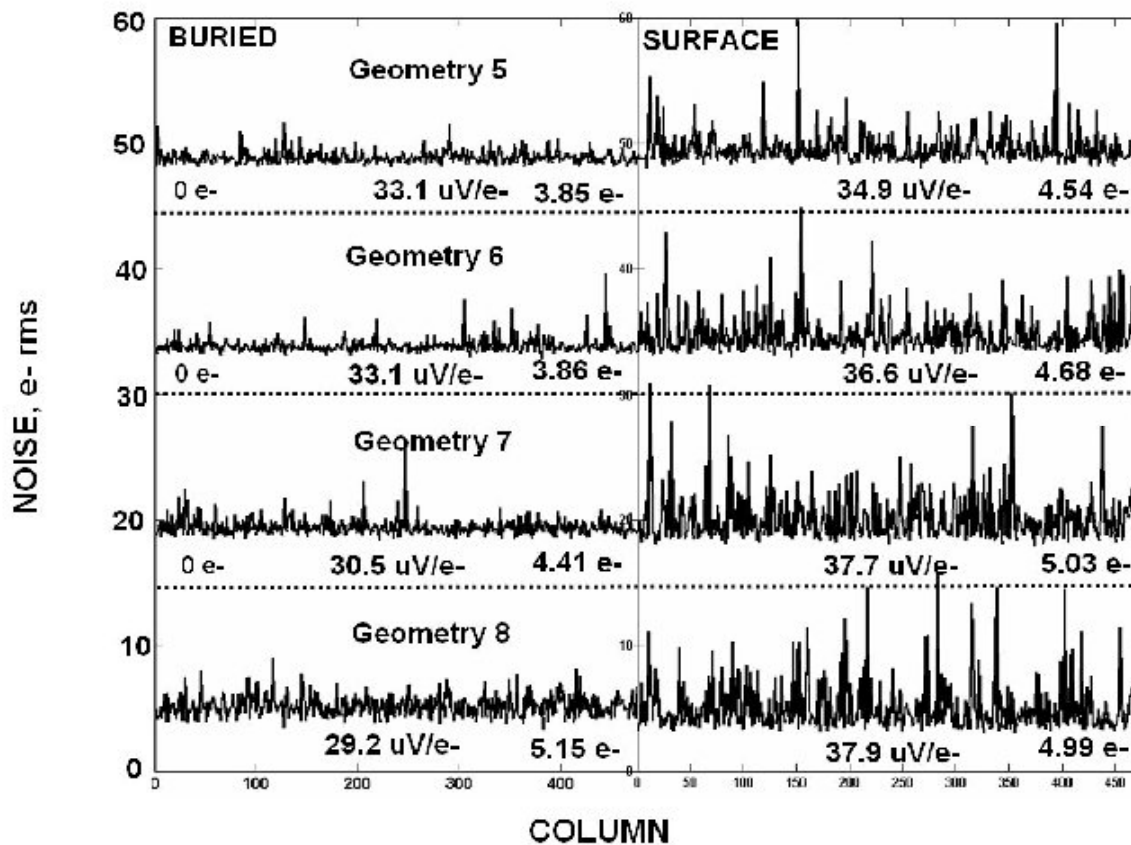

Janesick latest, week of 5 October, 2009

- It turns out that both funnel and register have been fabricated by e2V for confocal microscopy: 100% efficient for single photoelectrons – noiseless, by using LLL (L3) linear register

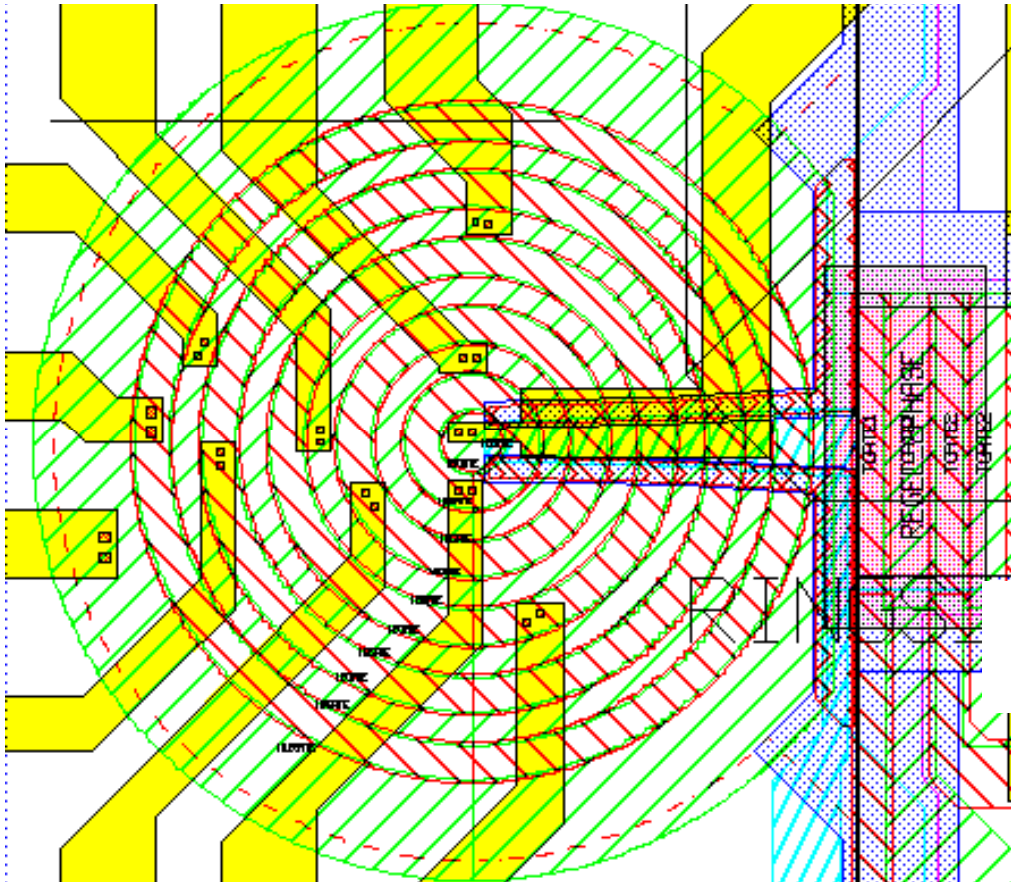

Diameter of outer active ring ~ 100 μm
[David Burt, e2V technologies]

ISIS: Imaging Sensor with In-situ Storage



- Pioneered by W F Kosonocky et al IEEE SSCC 1996, Digest of Technical Papers, p 182
- Current status: T Goji Etoh et al, IEEE ED 50 (2003) 144
- Frame-burst camera operating up to 1 Mfps, seen here cruising along at a mere 100 kfps – dart bursting a balloon
- Evolution from 4500 fps sensor developed in 1991, which became the de facto standard high speed camera (Kodak HS4540 and Photron FASTCAM)
- International ISIS collaboration now considering evolution to 10^7 – 10^8 fps version!