

# Engineering perspectives on quadrants

- (1/2) Experience on our first quad (Higo)
- (2/2) Perspective on quad (Higashi)

CLIC09, Oct. 12-16

T. Higo (KEK)

# Contents

- Quadrant
  - Fabrication of quads
  - Surface treatment
  - Assembly of four quads
  - Tuning
  - Vacuum chamber
- SiC material

# KEK's version: 50 micron chamfer

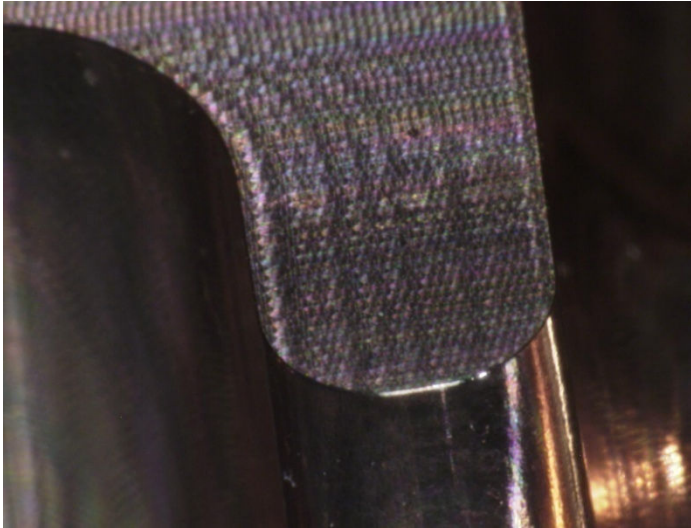

Made of **CuZr** without heat treatment.

**50 micron rounding**: shape with **angles and bumps**.

**Reference planes** were formed by milling in a **few micron level** without re-chucking for shaping cells.

**Assembly** was done within **ten micron level**.

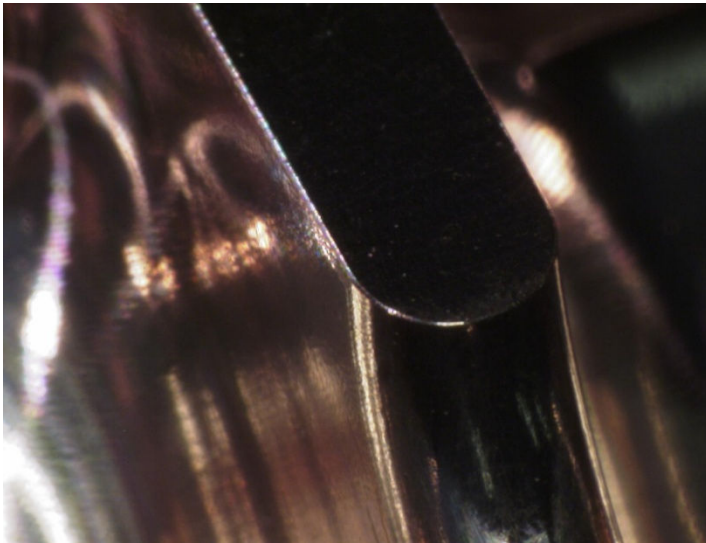

# Possible cause of high dark current

## Field enhancement due to round chamfer

- Simulation of field enhancement
  - 1.4 ~ 1.6 at radius
  - with  $\text{gap} < \text{radius}/5$ ,  $\text{step} < \text{radius}/2.5$
- Only a few tool passes
  - to shape 50 micron radius
  - with radius tool of 2mm
    - If three passed  $\rightarrow$  tangential discontinuity by about 30 degree
    - Can be relaxed by such as EP in future

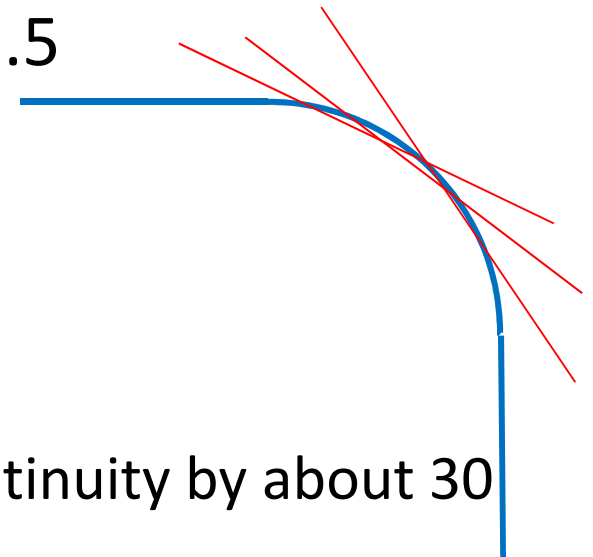

# Electric field enhancement in a shallow channel with round chamfer

Calculation done by T. Abe by CST MS. Waveguide field.

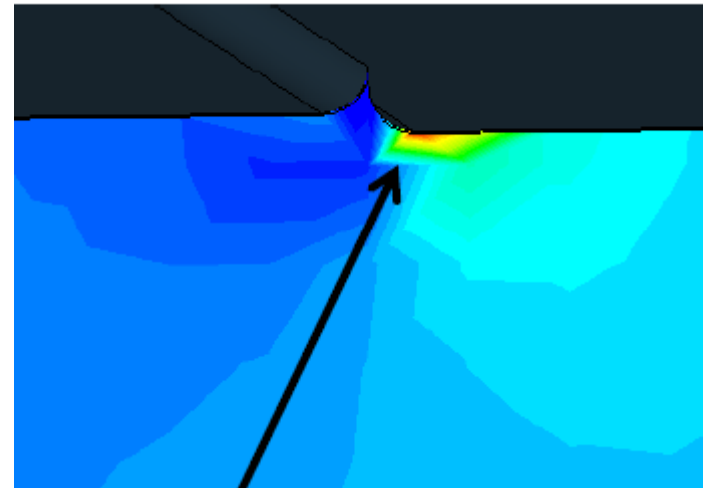
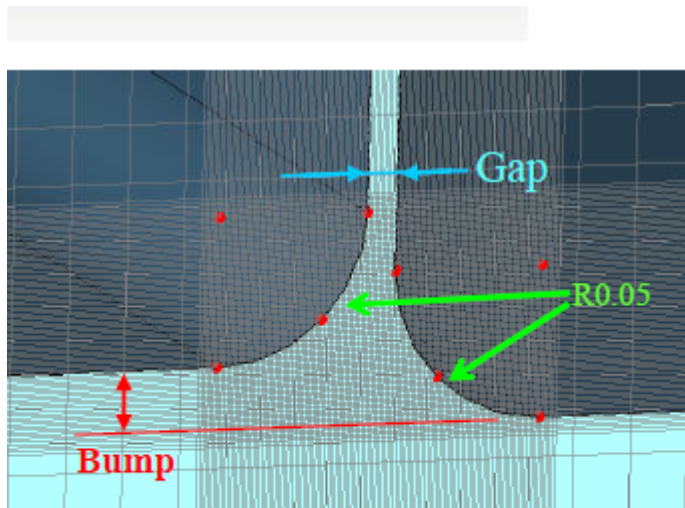

Gap (micron)	Bump (micron)	$E_{max} / E_{nominal}$
0	0	1.39
0	20	1.57
10	20	1.58

# Detailed shape at R0.05 chamfer

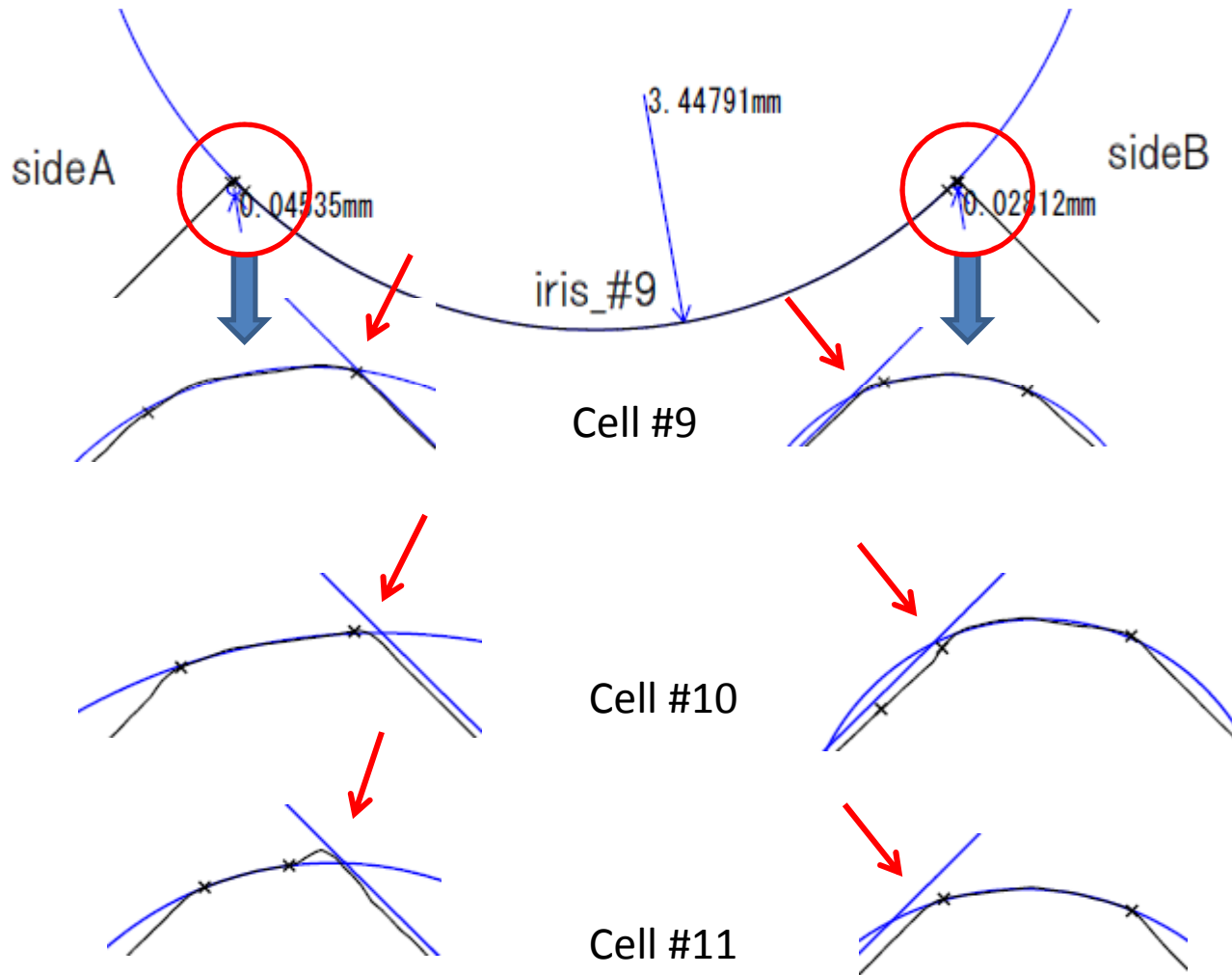

Only 2~3 tool passes over R0.05 90deg rounding.

Not tangential connection from smooth surface. 30-40 degree edge emerges.

Sharp edges or bumps exist at the rim.

# Production of quadrant Q1-1

Green lines are  $\pm 2.5$  microns.

Followings shows worst part out of four measured areas along the axis.

Local shape is smoothly connected.

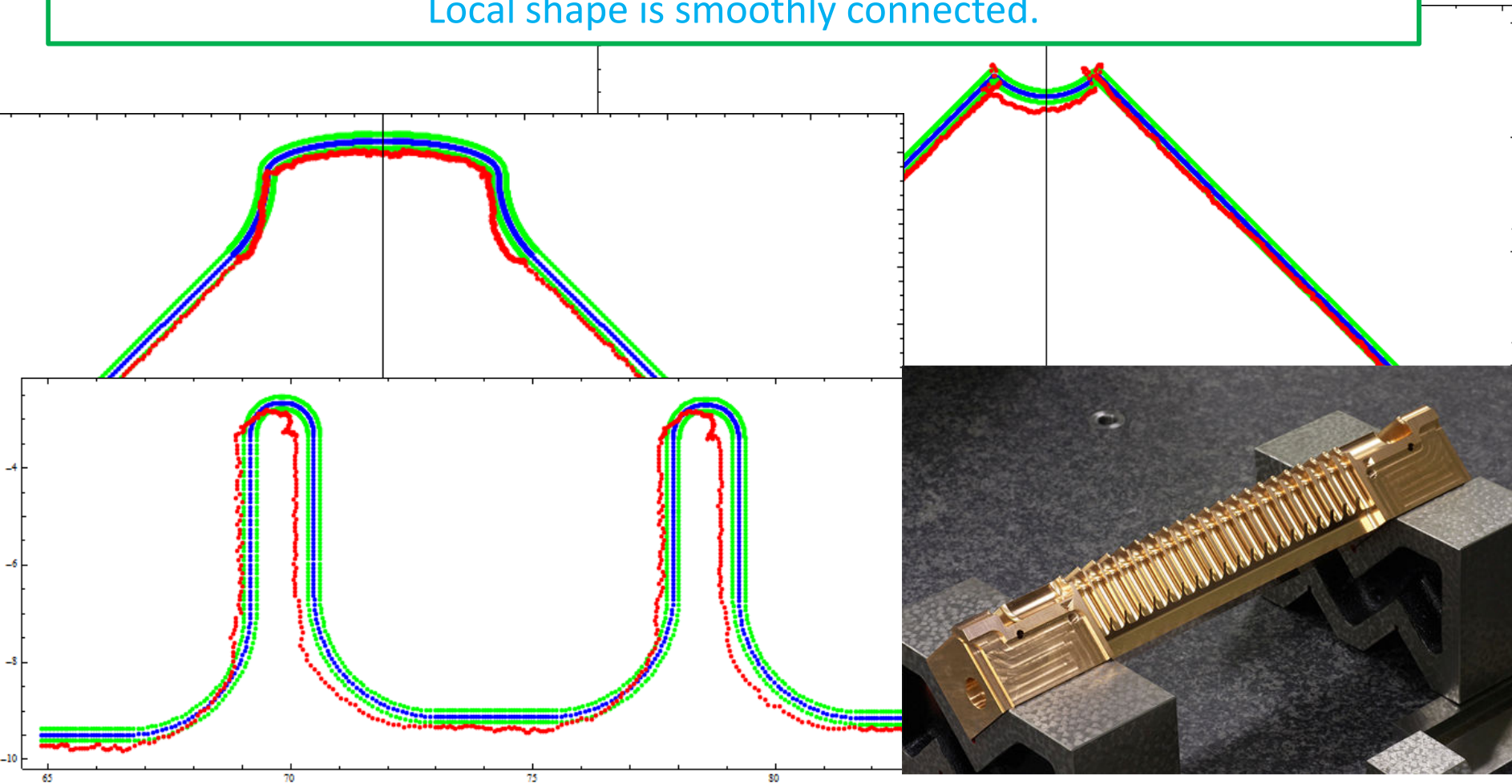

# Cleaning: **no etching**

- Alcohol bath
  - with ultra-sonic vibration for 5 minutes.
- Acetone bath twice
  - with ultra-sonic vibration for 5 minutes.
- Nitrogen blow
- Storage in a deccicator
  - Initially filled with nitrogen gas.
  - Storage for more than a month.



# Assembly

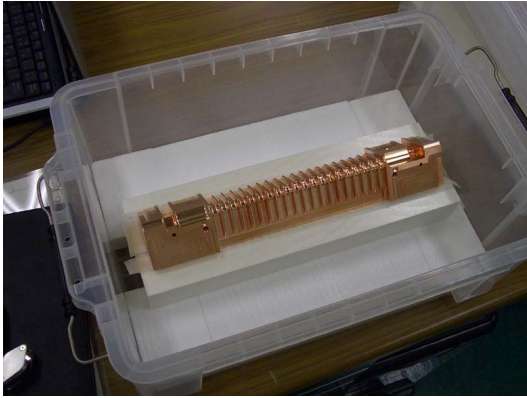

Carry and storage

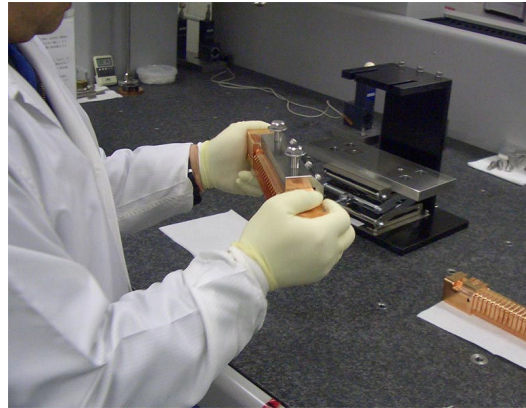

First hanging

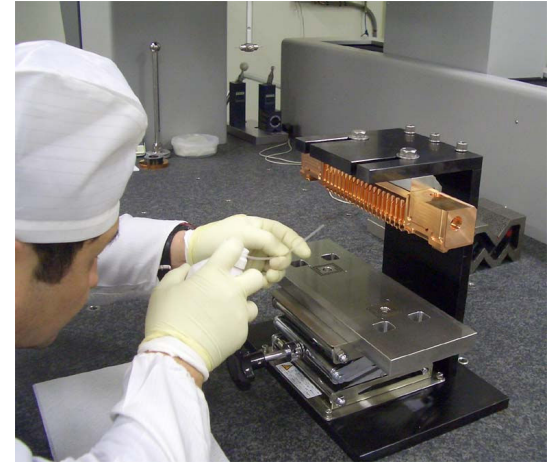

Prepare next quad approach

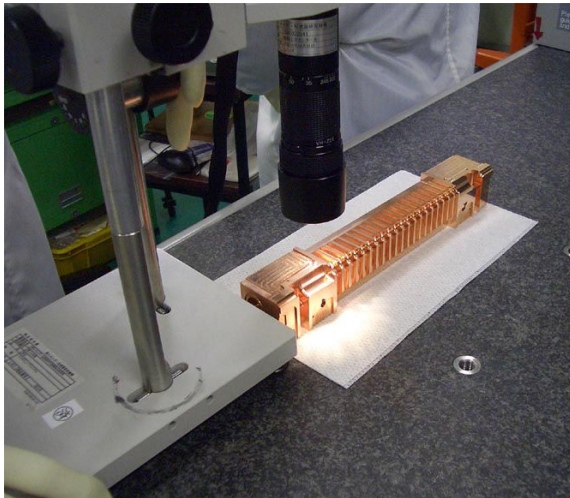

Edge inspection



Check ball diameter

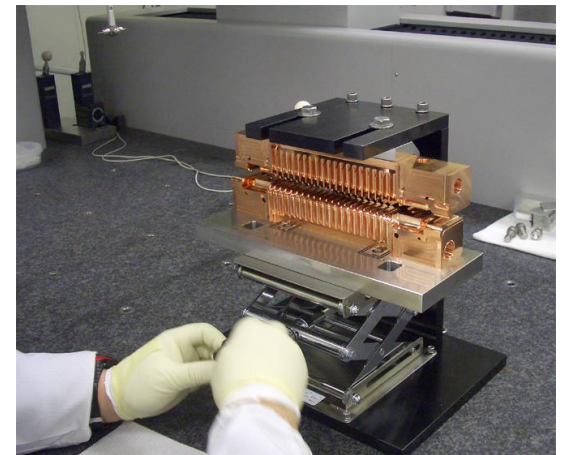

Second hanging

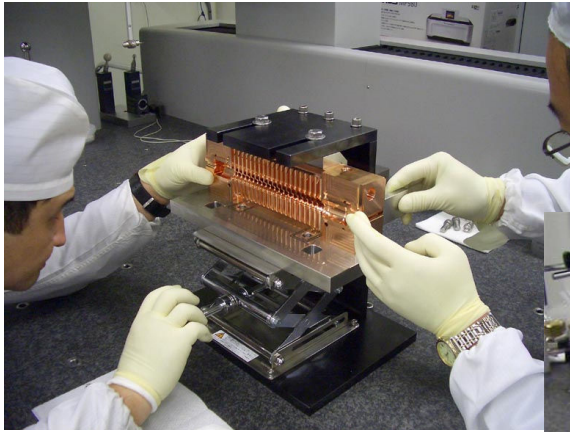

Fine adjustment

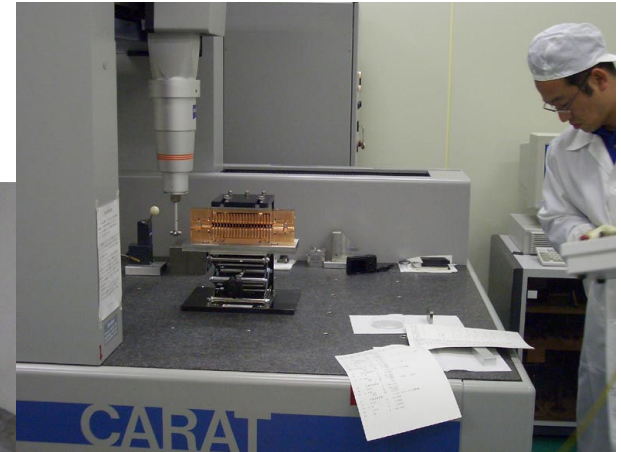

Alignment checking

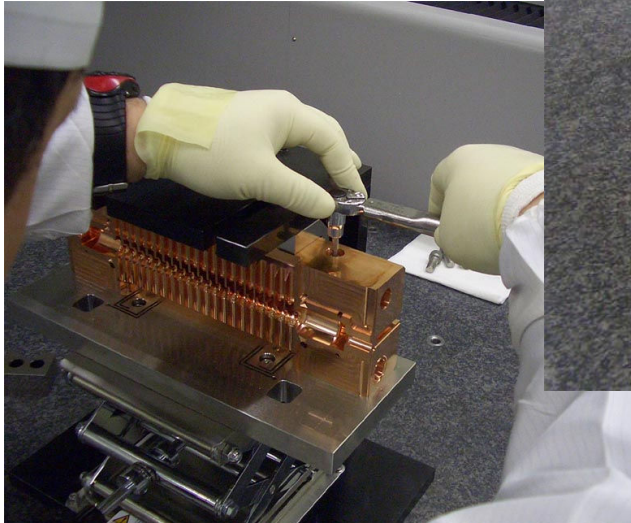

Fixing by bolt

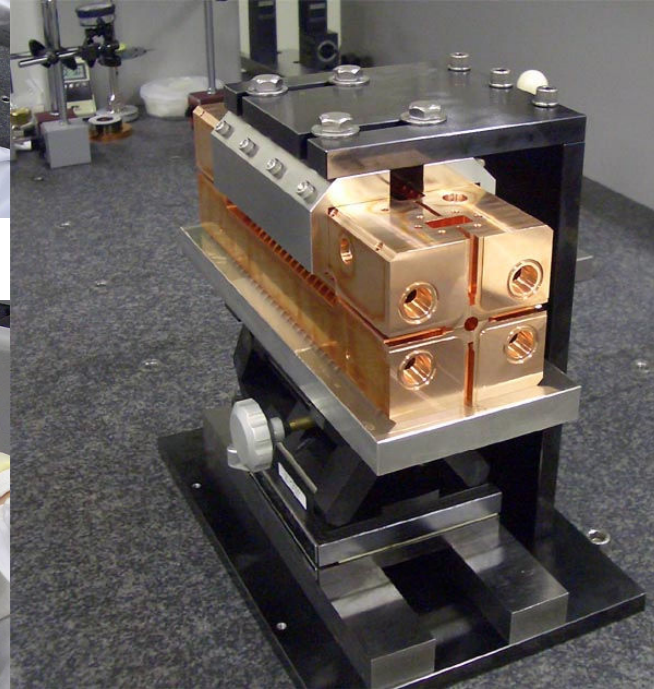

Completion of stack

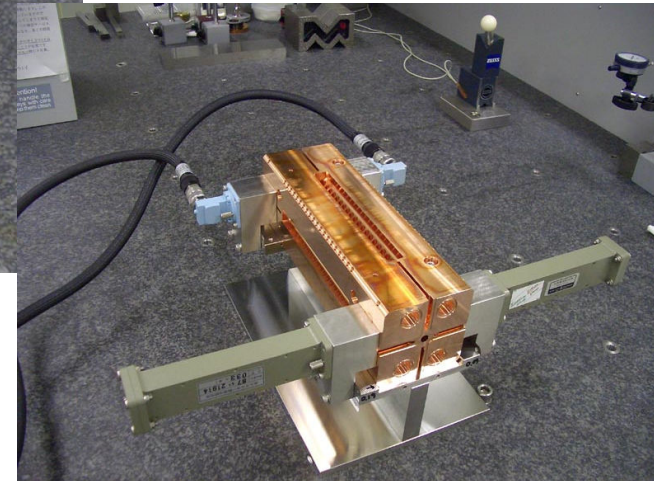

RF setup

Manual adjustment before final pressing, without ball and groove mechanism. Misalignment: within ten microns.

Reproducibility: a few microns.

2009/10/12

CLIC09

10

# Final alignment

Misalignment of each quadrant  
w.r.t. the average of four quadrants  
(units are in micron)

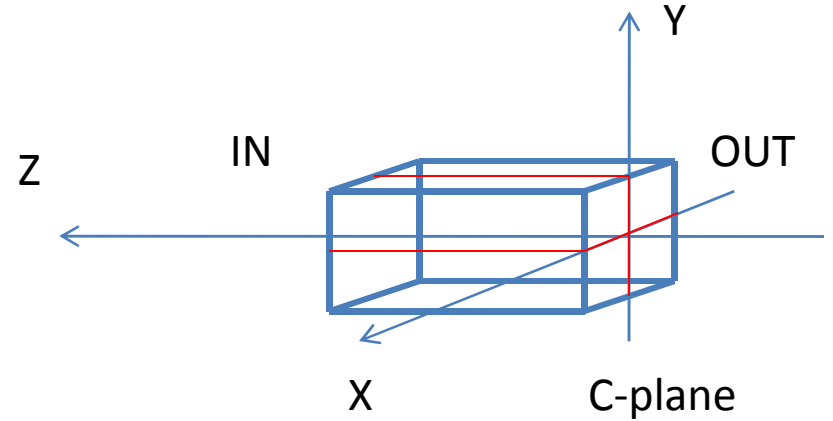

### Input side

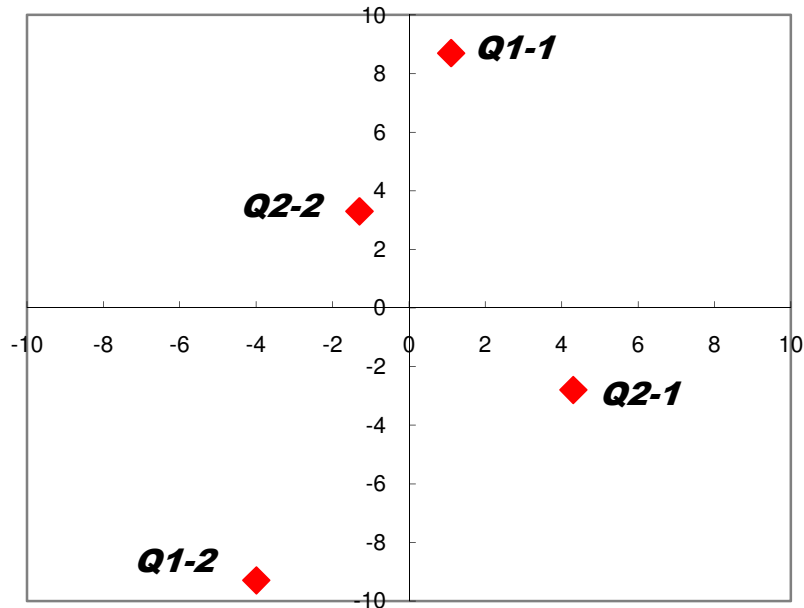

### Output side (C-plane)

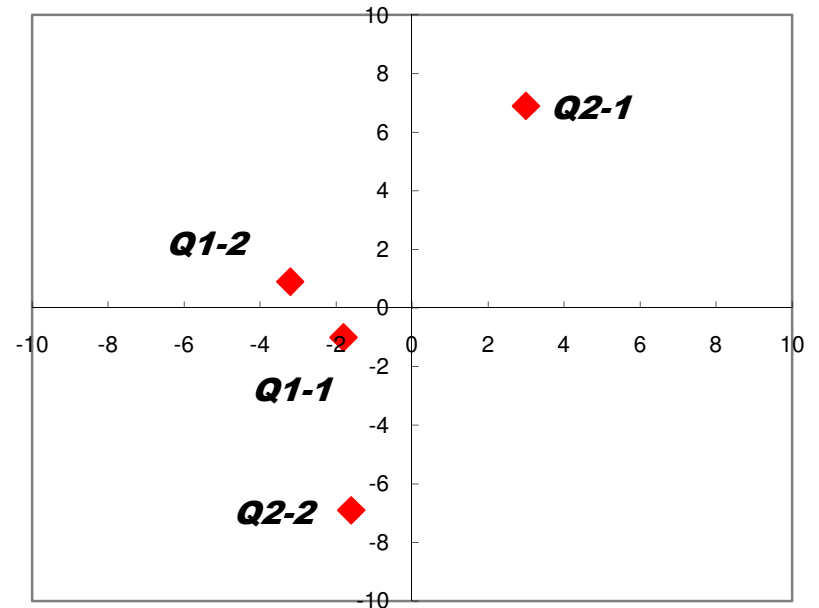

# Elastic tuning with a ball being kept push

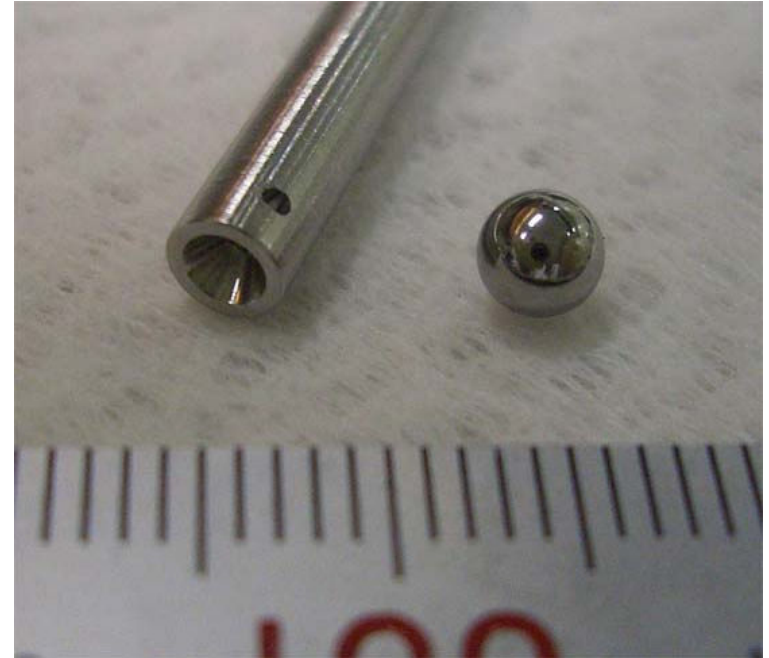
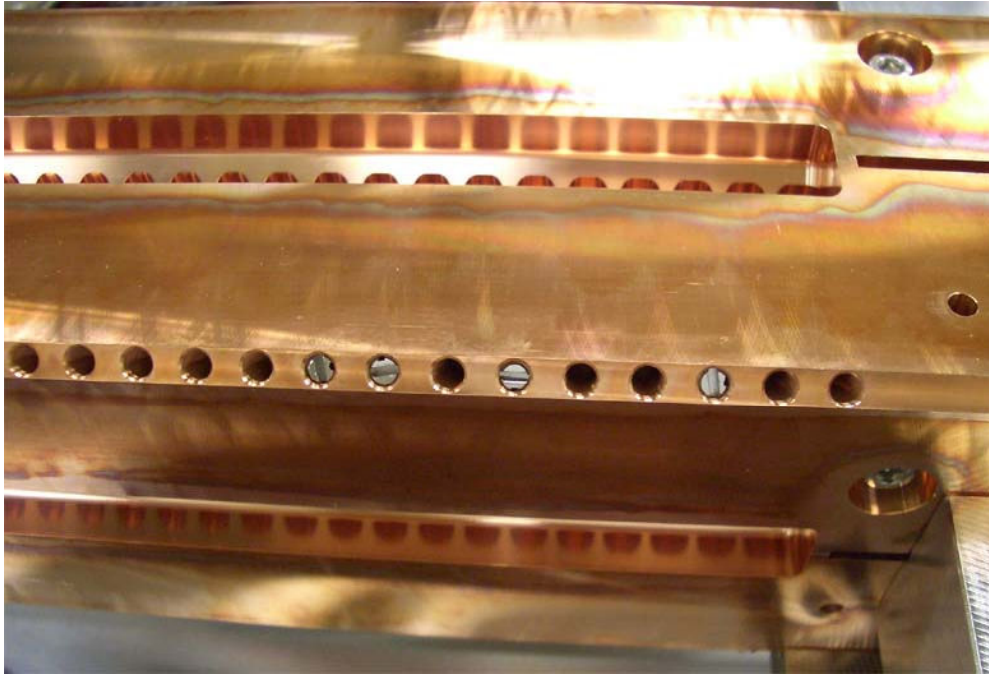

4mm stainless ball pushed by minus watch driver.  
Pushing by turning with Higo's hand full force.  
Elastic deformation kept, meaning that the tuning pins  
are kept pushing the balls.

# Notice: Deformed cavity wall

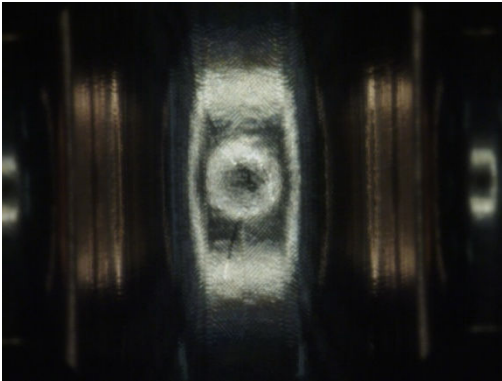

Cell 3( $\times 35$ )

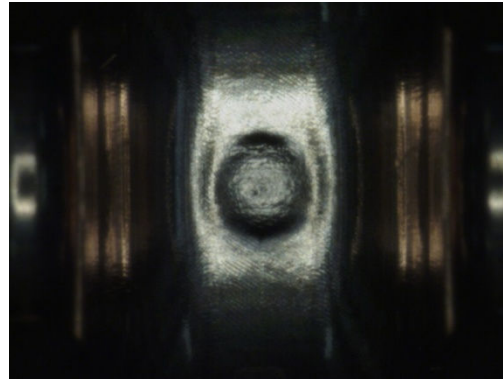

Cell 8( $\times 35$ )

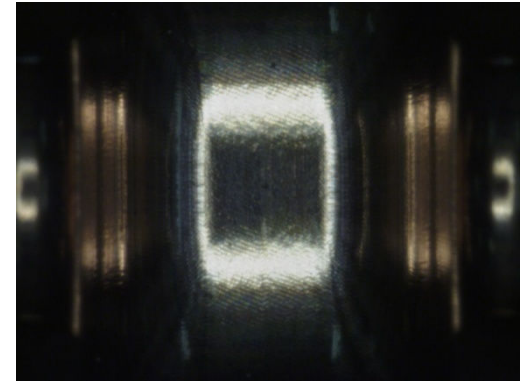

Cell 10( $\times 35$ )

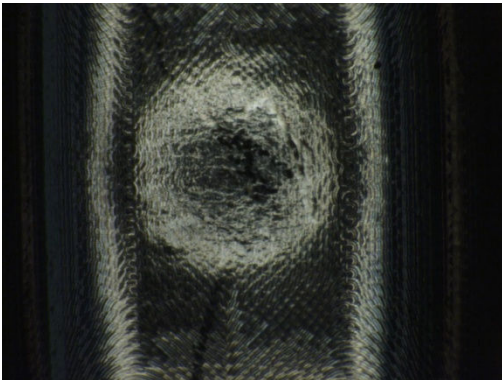

Cell 3( $\times 100$ )

Cell3 deformation : 0.053mm

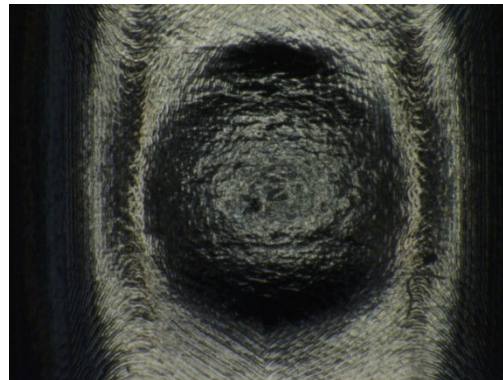

Cell 8( $\times 100$ )

Cell8 deformation : 0.167mm

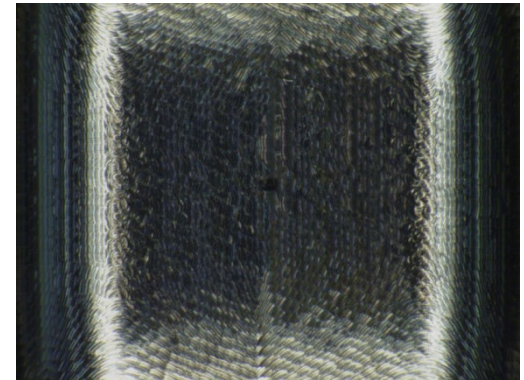

Cell 10( $\times 100$ )

Cell10 no tuning

# Field smoothness after tuning good.

Raw amplitude of bead pull measurement  
bead pull # 14-20-28-32

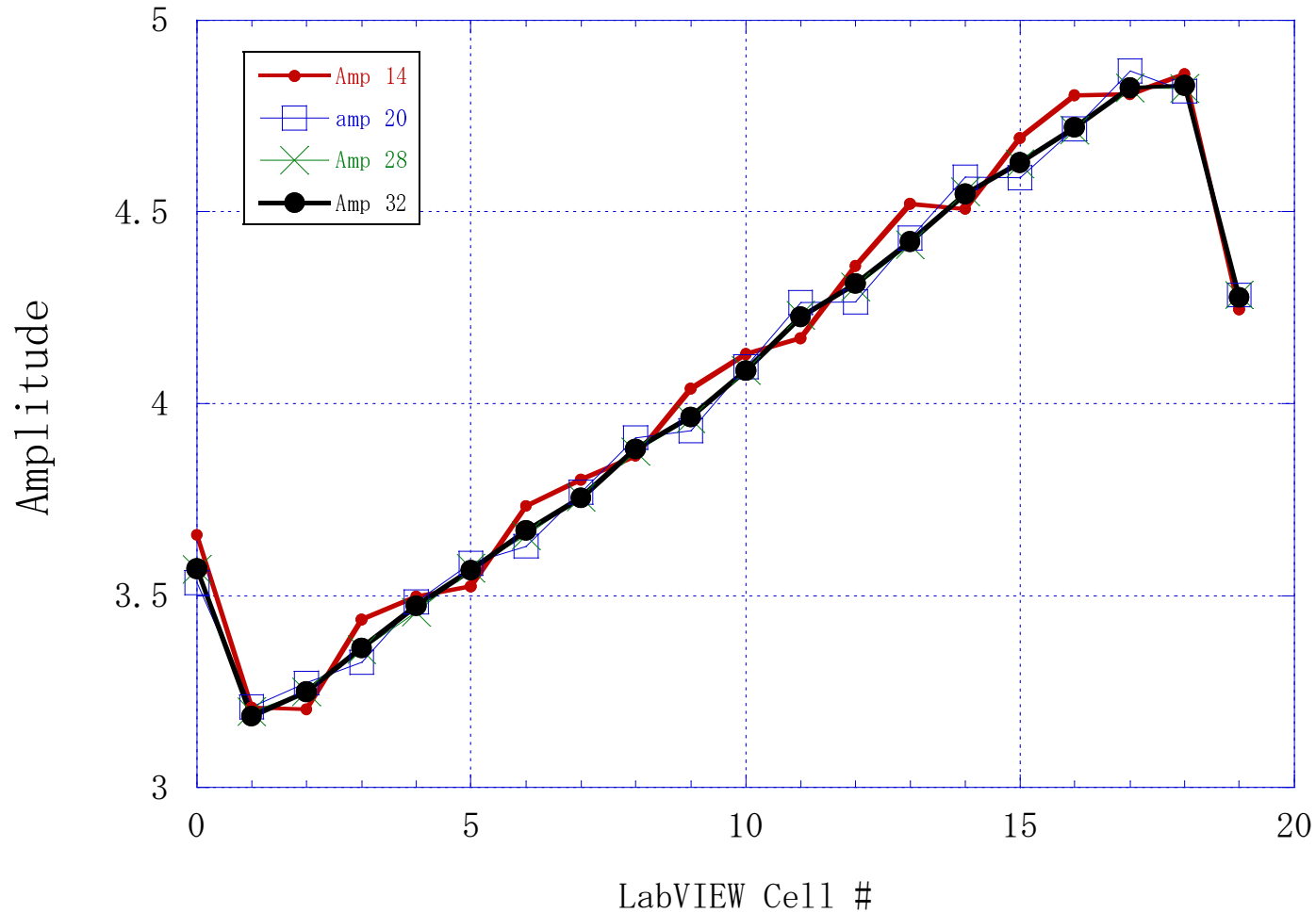

# Vacuum chamber design

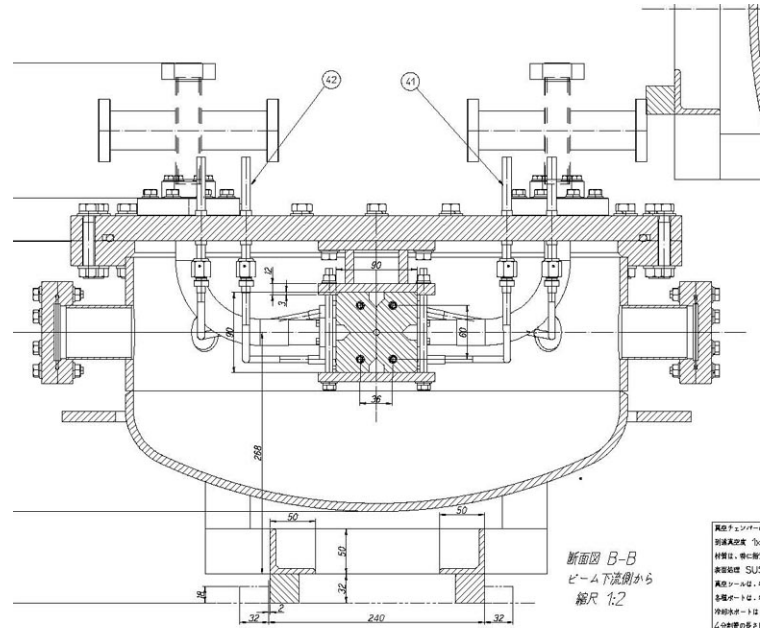
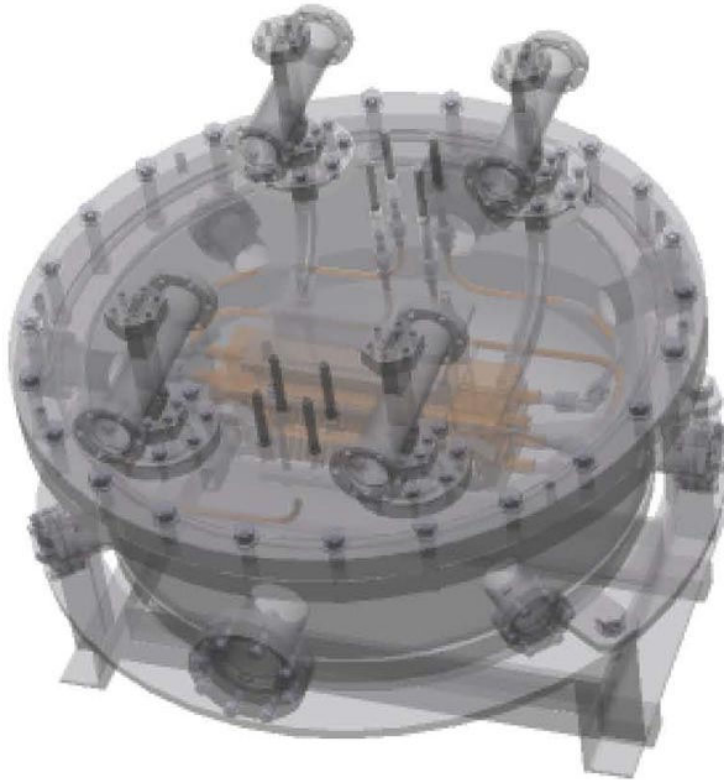

U-tight seal (round metal gasket)

VCR connector for cooling water connection

Thin H-bend being vac sealed with bellows

Vac evacuation from CF114 mounted on chamber with IP 70l/s and from WR90 at just 0.5m from structure

# Installation into chamber

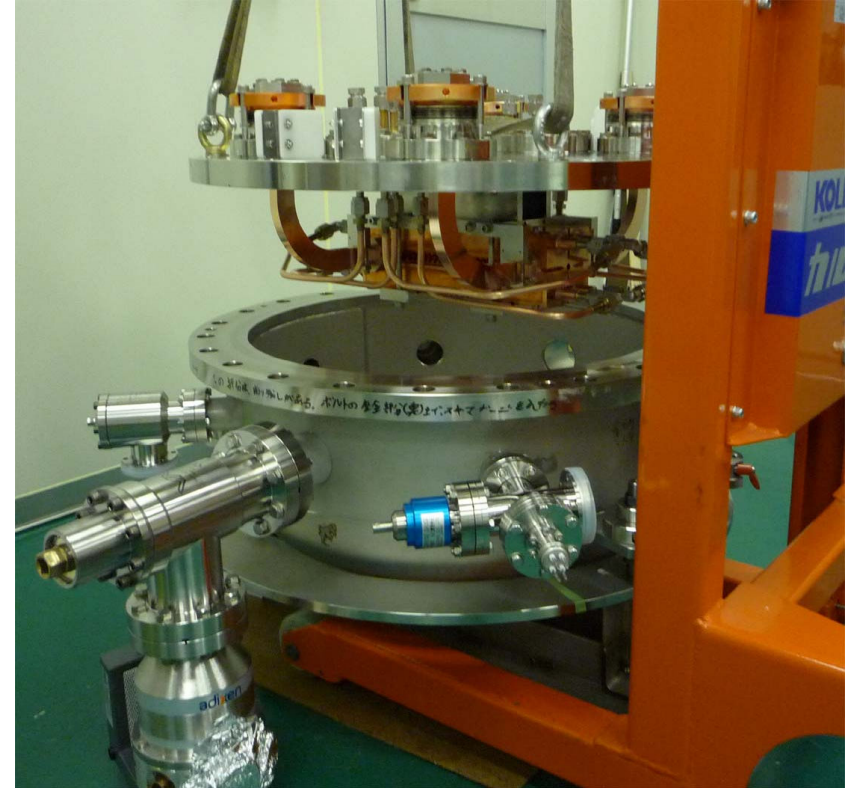
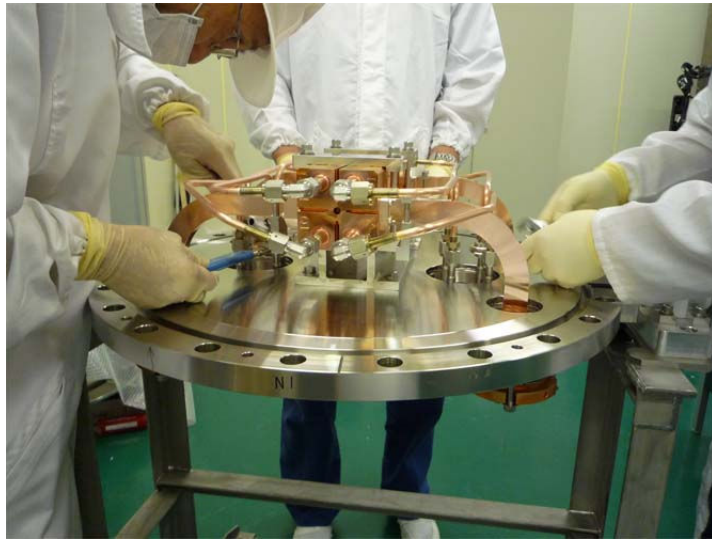



# Evacuation with quad structure

as of 090612

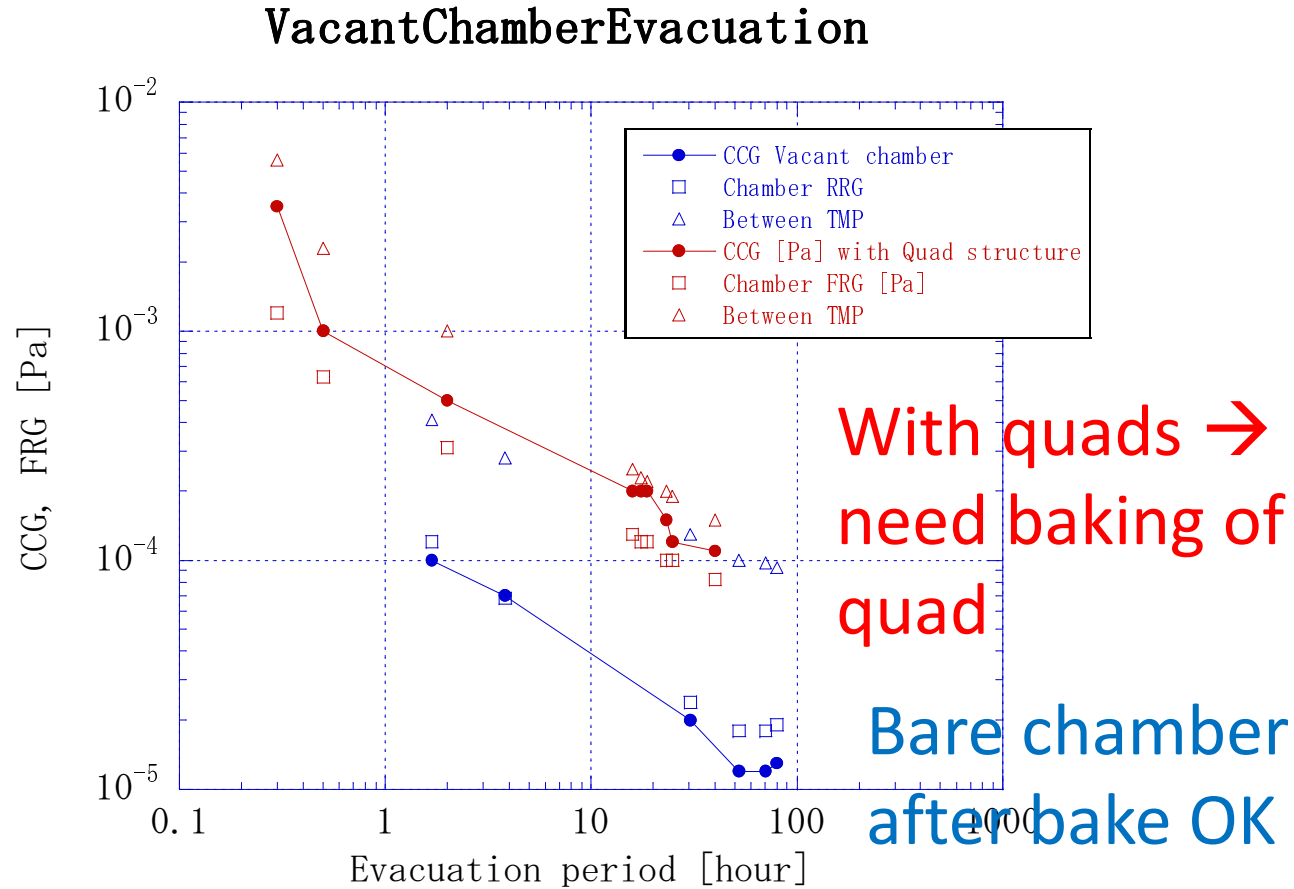

# First installation to Nextef but,

as of 090622

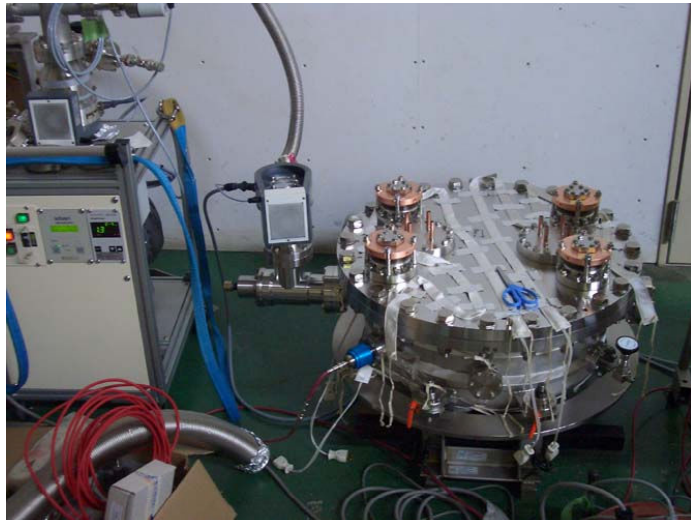

### Chamber Evacuation

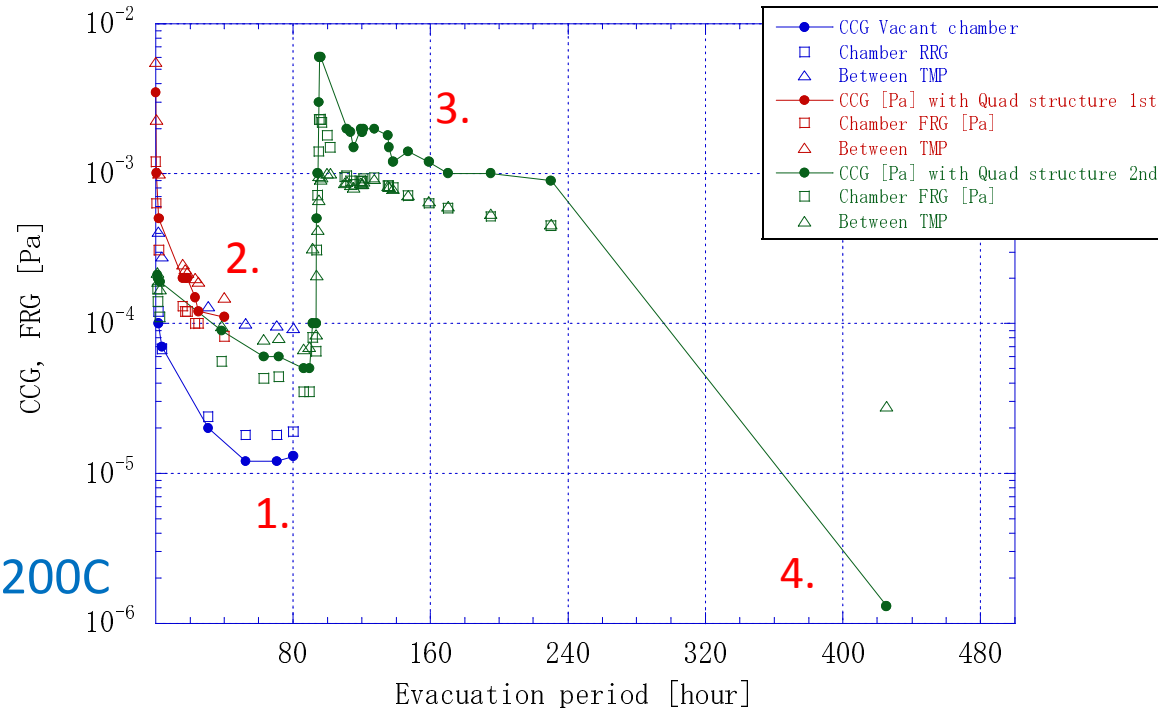

1. Firstly baked without quads at ~200C  
→ Reached 10<sup>-5</sup>Pa

2. Quad into chamber → 10<sup>-4</sup>Pa

3. Then baked with quads ~200C → Reached 10<sup>-6</sup>Pa

4. Moved to Nextef but the

**stuck gaskets prevent quad from connection to waveguide**

→ Removed gaskets by oil-less milling with cutting flange surface

→ Reinstalled into chamber without baking.

# Installed into Nextef

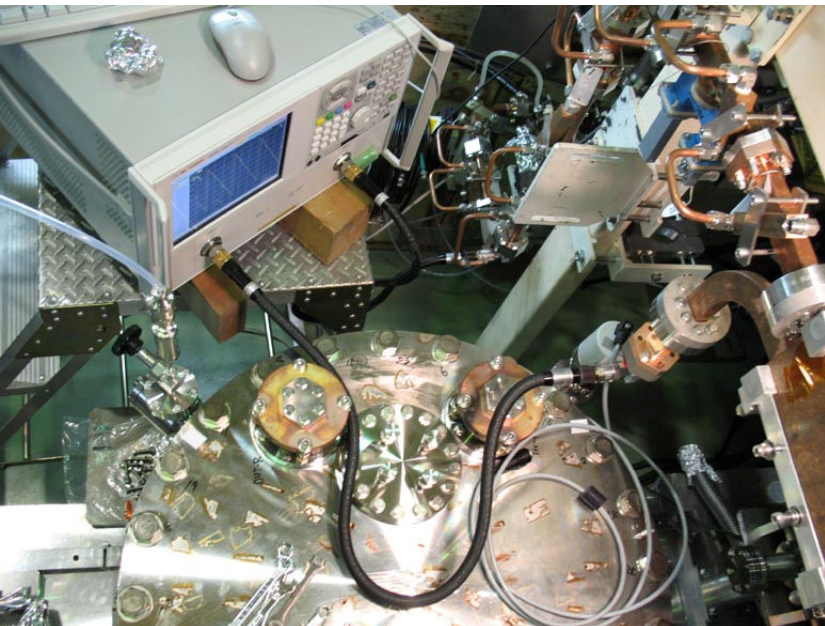

3dB phase check

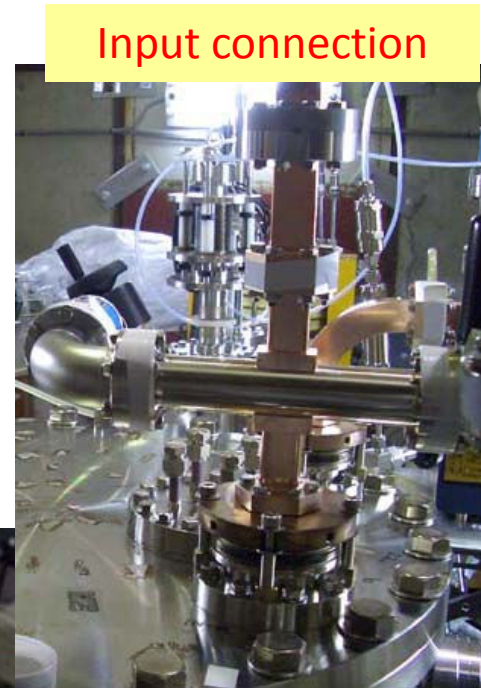

Input connection

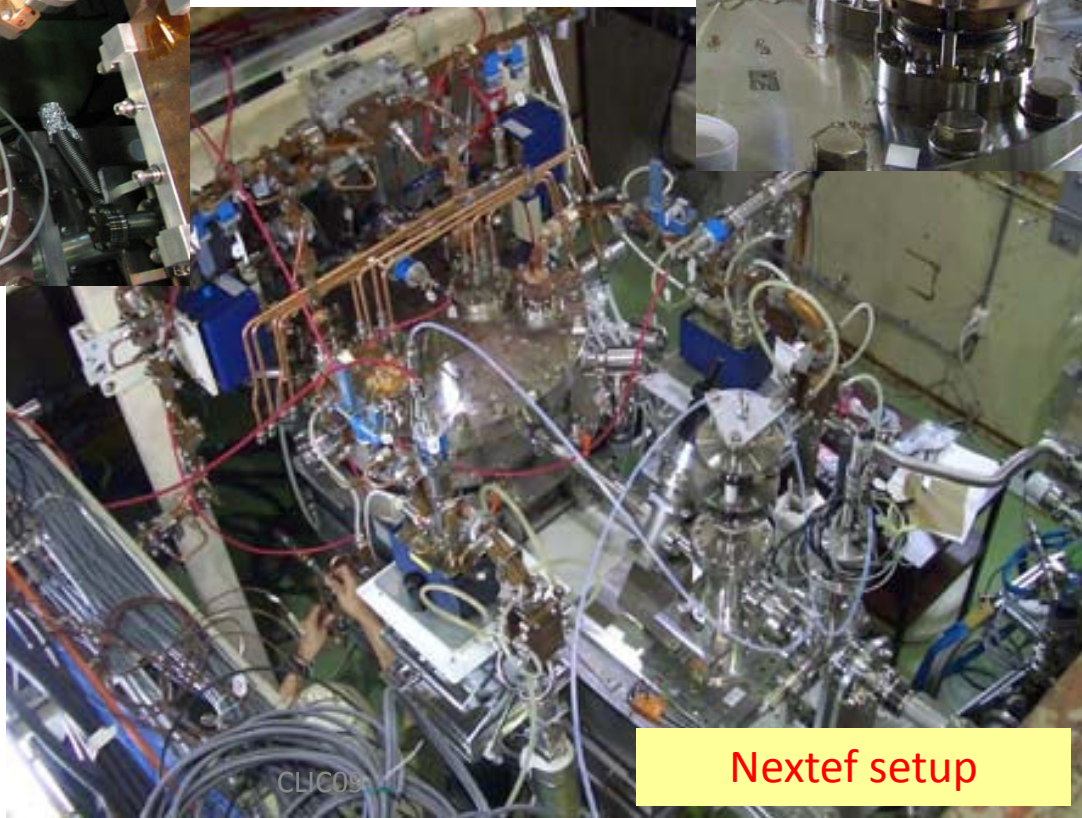

Nextef setup

# Evacuation of quad at Nextef

Evacuation July 17-24

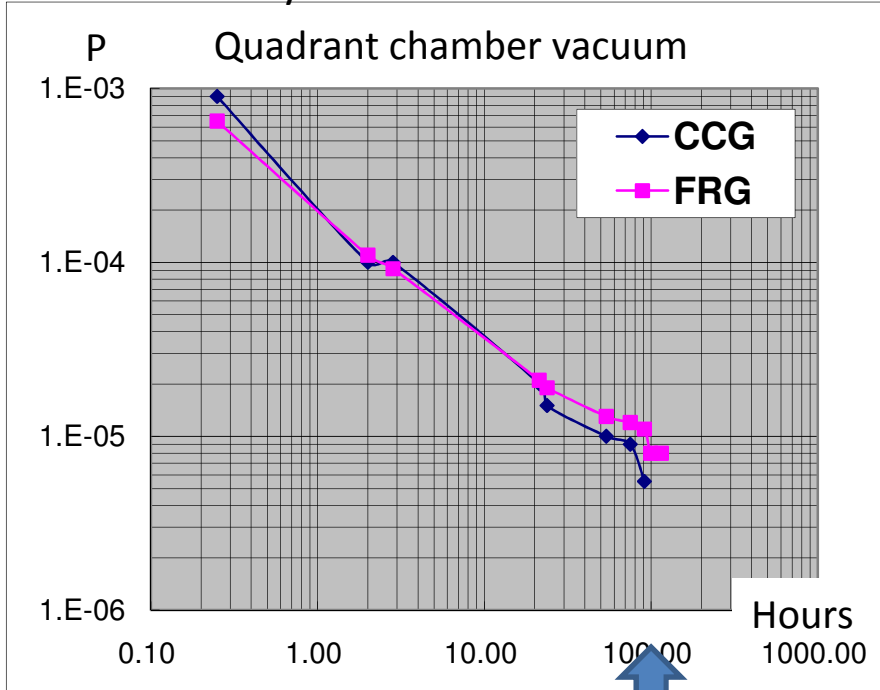

Start evacuation by IP

Evacuation with TMP through CF114  
 Prepare IP with baking, while evacuation by TMP  
 through ICF70

Evacuation with IP

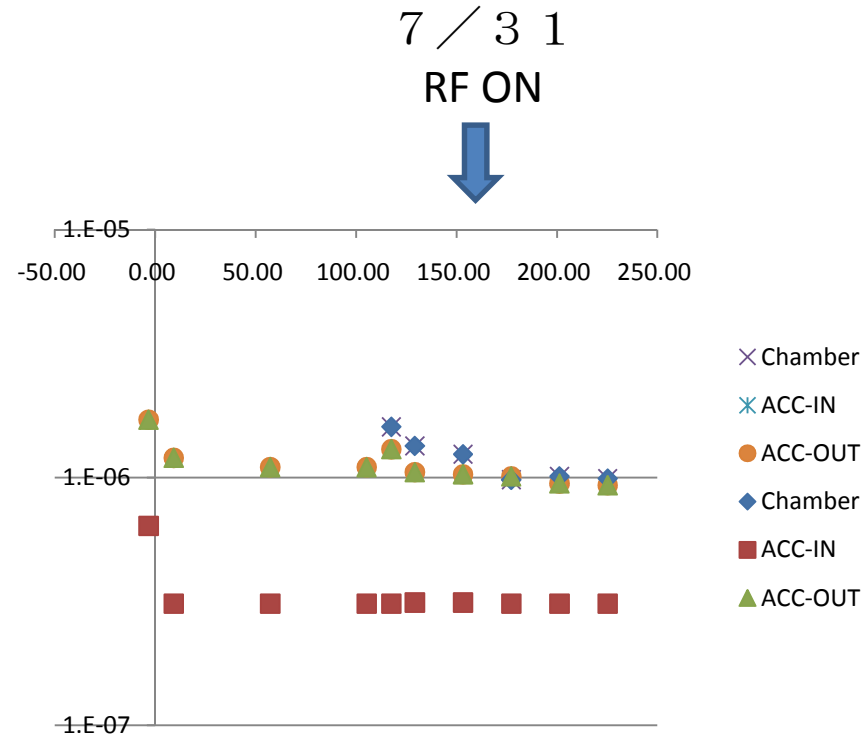

Reached  $10^{-6}$  Pa with IP  
 → Then RF-ON

# Vacuum of quad

- Base pressure reached  $10^{-6}$ Pa
  - Nearly one order of magnitude worse than T18\_Disk (a few  $10^{-7}$ Pa)
  - Taking good vacuum conductance from gauge to RF pass, vacuum level inside is estimated to be close to T18\_Disk
- Gas activity with RF
  - Should carefully be studied to see what is happening inside due to RF and sometimes breakdowns
  - We may get some hint to understand breakdown

# Hitachi's second try of quad fab.

- Hitachi engineer tried again a quad test production.
- It reached the similar level as those of Quad#5.
- Milling done with 3D milling machine but adding another rotational motion.
- Company engineers are interested in the quad production.
- They are watching our perspective.

# Conclusion to pass to Higashi's talk

- First Quad by KEK was now in high power test.
- Many features are still in question
  - responsible for the poor high gradient property?
- However, we want to use it as our education to understand breakdown.
- Quad approach:
  - We need to establish high gradient first,
  - Taking mass production perspective in mind.
  - → Higashi

# Some information on Lossy material

- SiC being studied by Y. Takeuchi
  - Based on material for HOM absorber of KEKB 500MHz cavity
    - SuperB chose low current/low emittance design
    - No extra funding for higher frequency development
  - Tried tuning to higher frequency
    - By changing doping amount
  - Mostly by two companies
    - Covalent and Hitachi chemical



# Adjustment of the permittivity of SiC ceramics

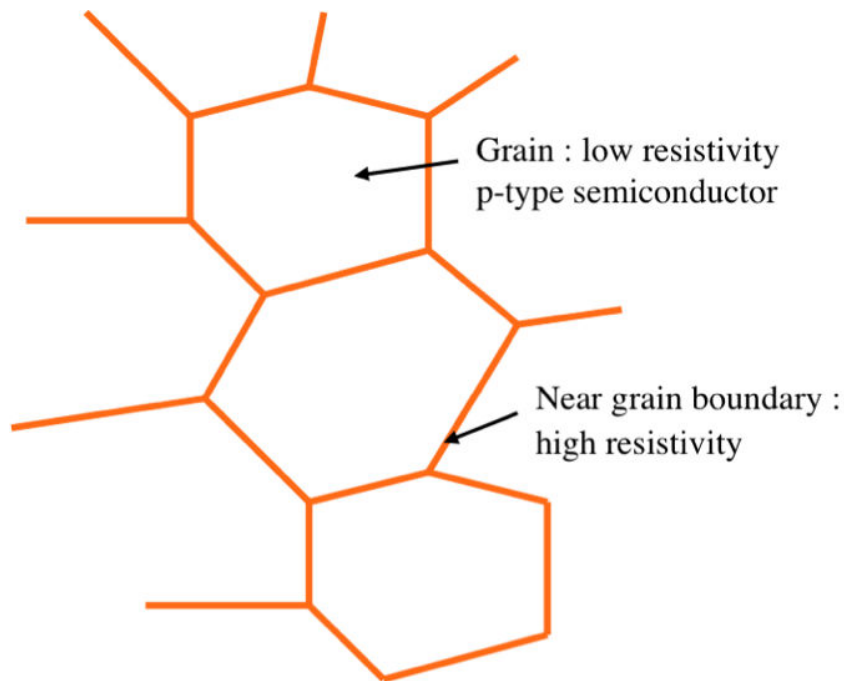

Schematic Model of SiC Ceramics

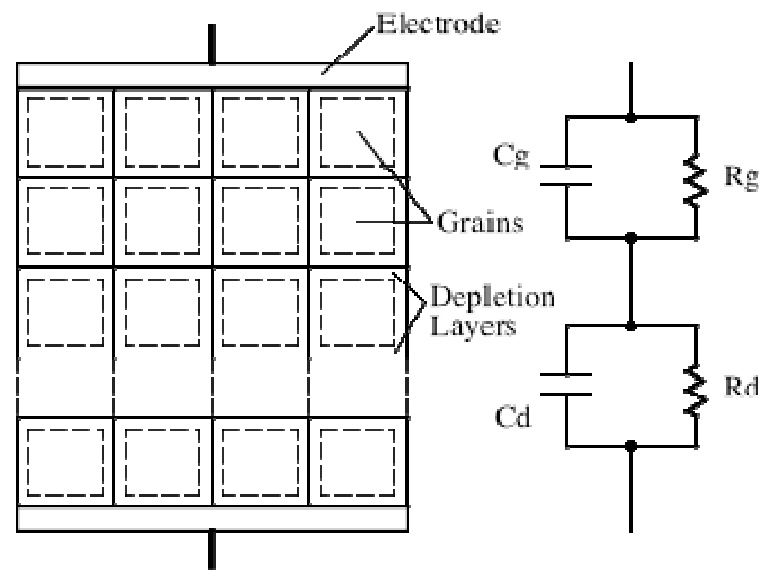

Two-layer Model and Equivalent Circuit

By doping Al-compound, we have tried to increase the carrier concentration in the grain. >>>> The relaxation time ( $\sim C_d R_g$ ) will change.

# Results of the doping (preliminary)

Covalent work in collaboration with KEK.

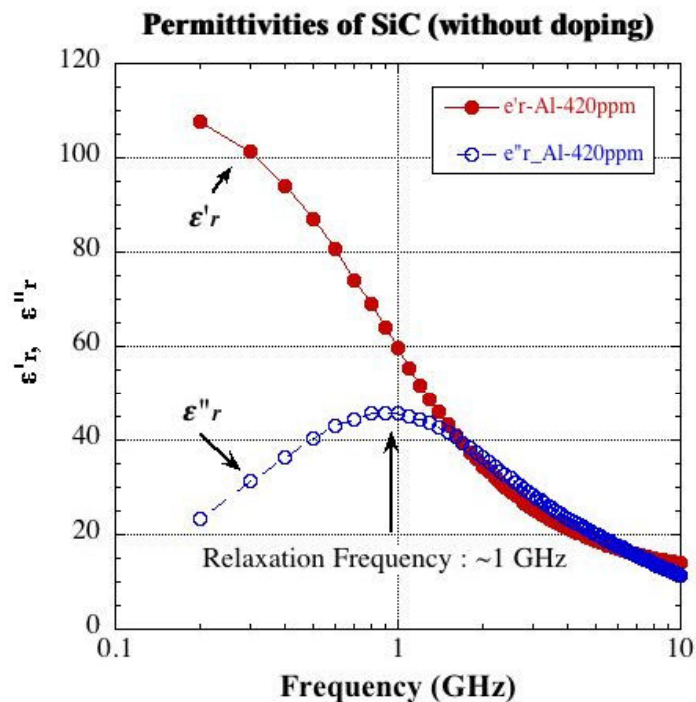

Al : 420 ppm(wt)

Relaxation time  $\tau \sim 1.6 \times 10^{-10}$  sec

Resistance  $19 \text{ M}\Omega$  (1 cm)

\* Relaxation frequency =  $1/(2\pi\tau)$

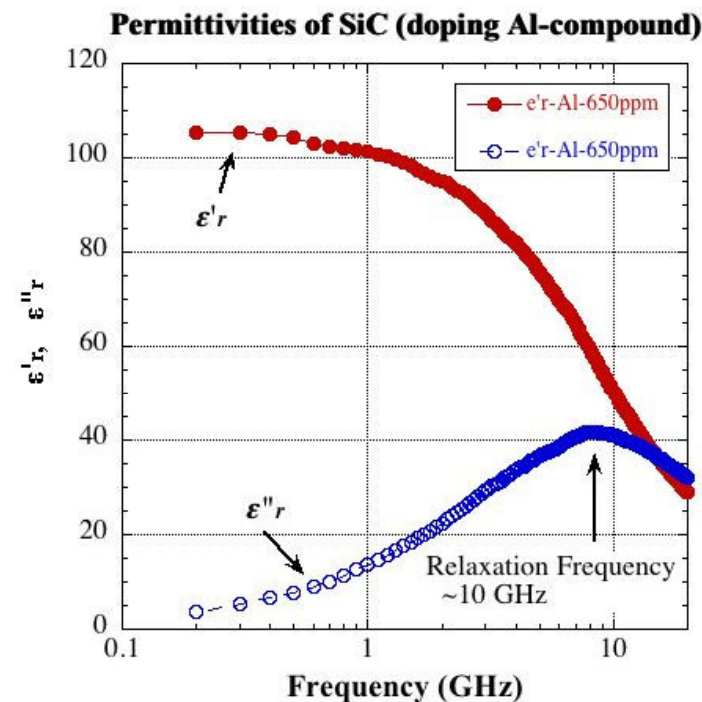

Al : 650 ppm(wt)

Relaxation time  $\tau \sim 1.6 \times 10^{-11}$  sec

Resistance  $0.8 \text{ M}\Omega$  (1 cm)

# SiC ceramics for higher frequency produced by HITACHI CHEMICAL

Hitachi Chemical did try and KEK measured.

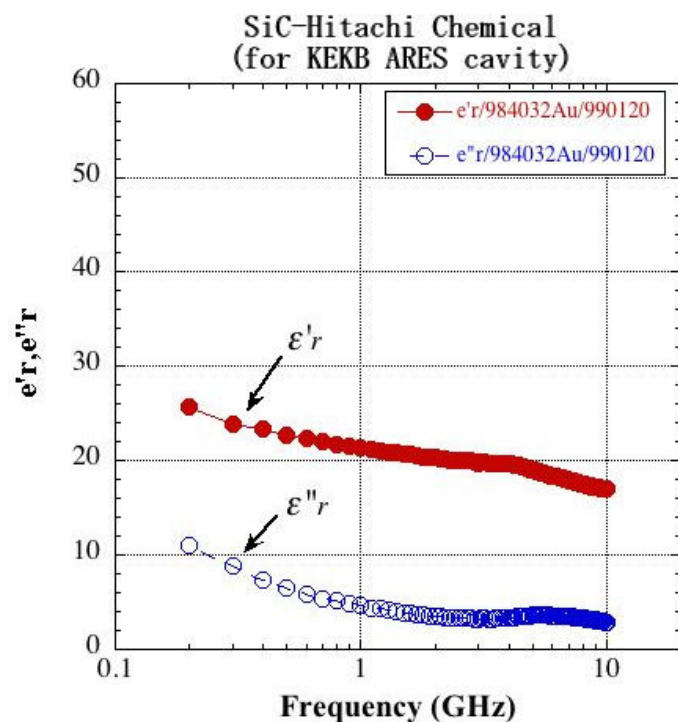

For KEKB ARES cavity

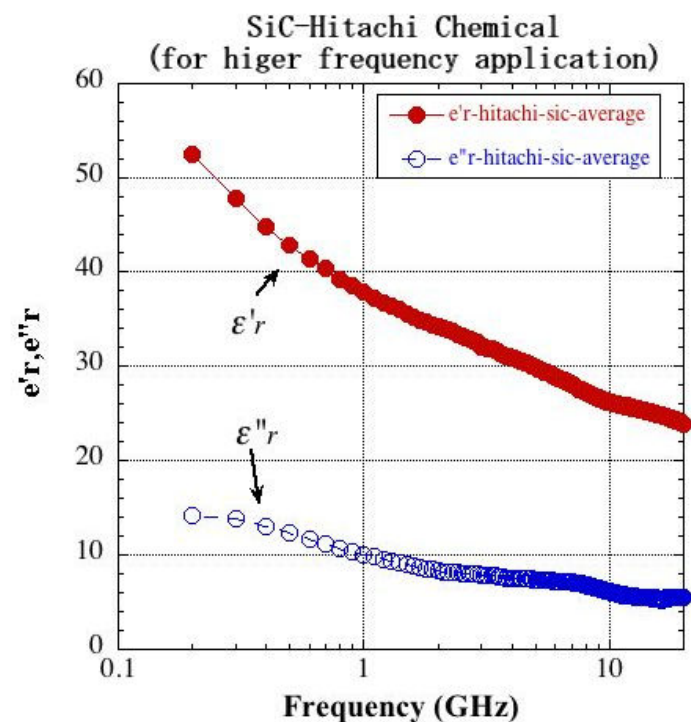

Developed to higher frequency

# For further info on SiC

- Please contact Takeuchi for further info in general.
- You can directly contact Covalent or Hitachi Chemical, for technical info and for production capability.
- KEK may make for accelerator structure use, depending on the success of TD24.
- If more for PETS
  - probably better to control production process by those who make PETS with the actual production company.