

Weakly Damped X-Band CLIC Accelerating Structures

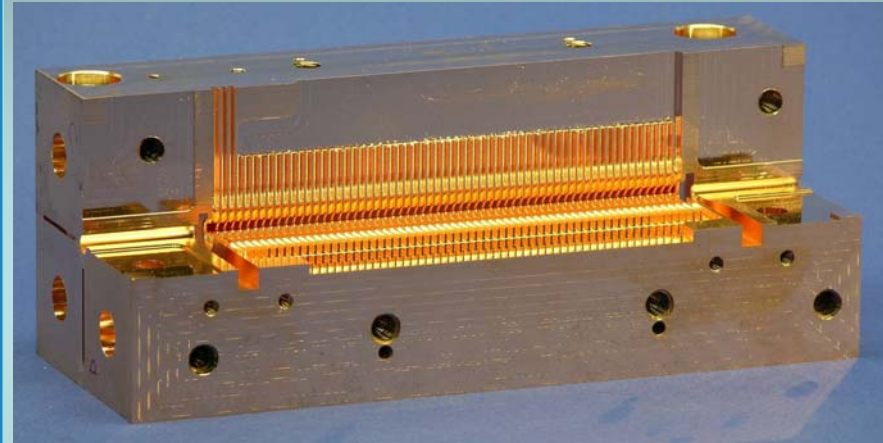

Roger M. Jones
**University Manchester, UK/
Cockcroft Institute, Daresbury, UK.**

March 12th – April 2nd, 2007.

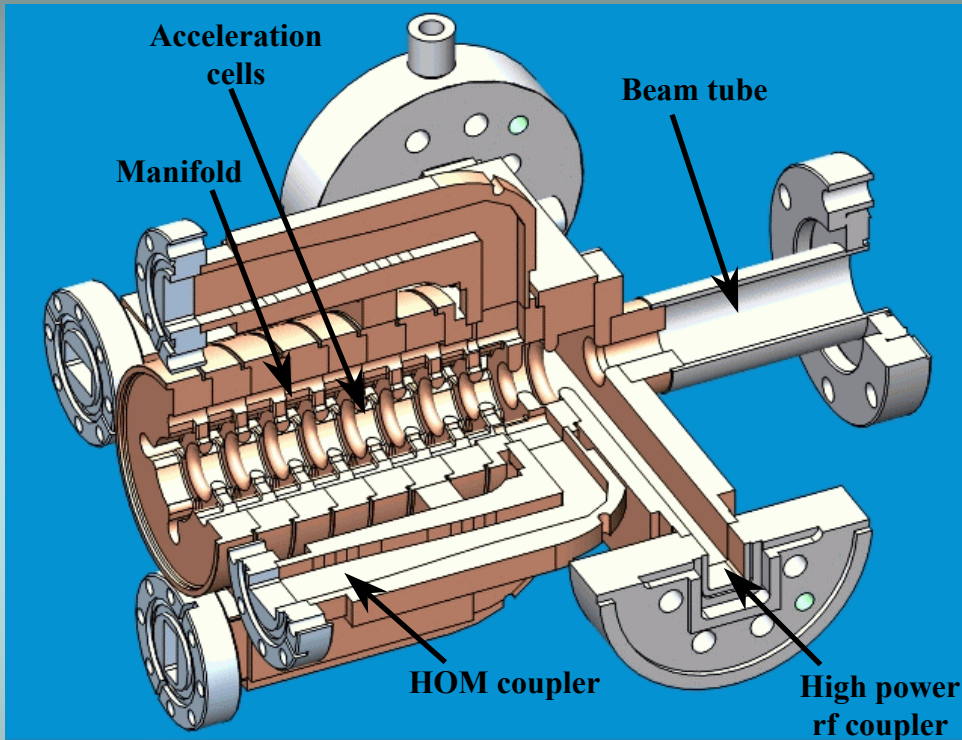

Fundamental Issues

- To make an analysis of the wake-field in a DDS-like CLIC structure requires a detailed analysis of the detuning and the damping.
- Here, we look into to the fundamental methodology that is needed and into the feasibility of undertaking such an approach to the CLIC accelerating cavities.
- The band structure is explored, together with the general approach which must be followed to reduce the damping: the need for non-linear interleaving in particular is highlighted

Overview

- Means of analysis of damping and detuning X-band structure
- Mode partitioning at 12 GHz
- Circuit model of dipole mode coupled to manifold
- Wakefield determination via spectral function
- Improved damping with interleaving of adjacent structures
- Tolerances achievable in fabricating these structures
- Experimental confirmation on two-fold interleaved X-band structure within ASSET facility at SLAC
- Implications on beam dynamics and relaxed tolerances

Parameters of WDS-120 protos @14.4Wu

Alexej Grudiev (CERN)

Structure number	maxFoM	2(minCost)	4	6	CLIC_14Wu
RF phase advance per cell: $\Delta\phi$ [°]	120	120	120	120	120
Average iris radius/wavelength: $\langle a \rangle / \lambda$	0.115	0.105	0.115	0.125	0.12
Input/Output iris radii: $a_{1,2}$ [mm]	3.33, 2.4	2.85, 2.4	3.33, 2.4	3.84, 2.4	3.87, 2.13
Input/Output iris thickness: $d_{1,2}$ [mm]	3.33, 0.83	1.5, 0.83	1.83, 0.83	2.00, 0.83	2.66, 0.83
Group velocity: $v_g^{(1,2)}/c$ [%]	1.44, 1.0	1.28, 1.0	1.93, 1.0	2.93, 1.0	2.39, 0.65
N. of cells, structure length: N_c, l [mm]	12, 112	23, 204	25, 221	24, 212	24, 229
Bunch separation: N_s [rf cycles]	6	6	7	7	7
Number of bunches in a train: N_b	278	106	83	77	120
Pulse length, rise time: τ_p, τ_r [ns]	188.2, 17.3	126.9, 17.7	115.1, 17.3	101.5, 17.6	160, 30
Input power: P_{in} [MW], $P/C_{1,2}$ [GW/m]	54, 2.6, 2.4	61, 3.4, 2.6	73, 3.5, 2.7	87, 3.6	76, 3.1, 2.7
Max. surface field: E_{surf}^{max} [MV/m]	262	274	277	323	323
Max. temperature rise: ΔT^{max} [K]	55	30	23 (const)	30	37
Efficiency: η [%]	25.9	19.0	18.4	19.3	21.5
Luminosity per bunch X-ing: L_{bx} [m ⁻²]	2.4×10^{34}	2.0×10^{34}	2.4×10^{34}	2.8×10^{34}	2.6×10^{34}
Bunch population: N	5.3×10^9	4.2×10^9	5.3×10^9	6.5×10^9	5.8×10^9
Figure of merit: $\eta L_{bx} / N$ [a.u.]	11.6	8.8	8.3	8.3	9.5

Design of X-Band Damped and Detuned Structure

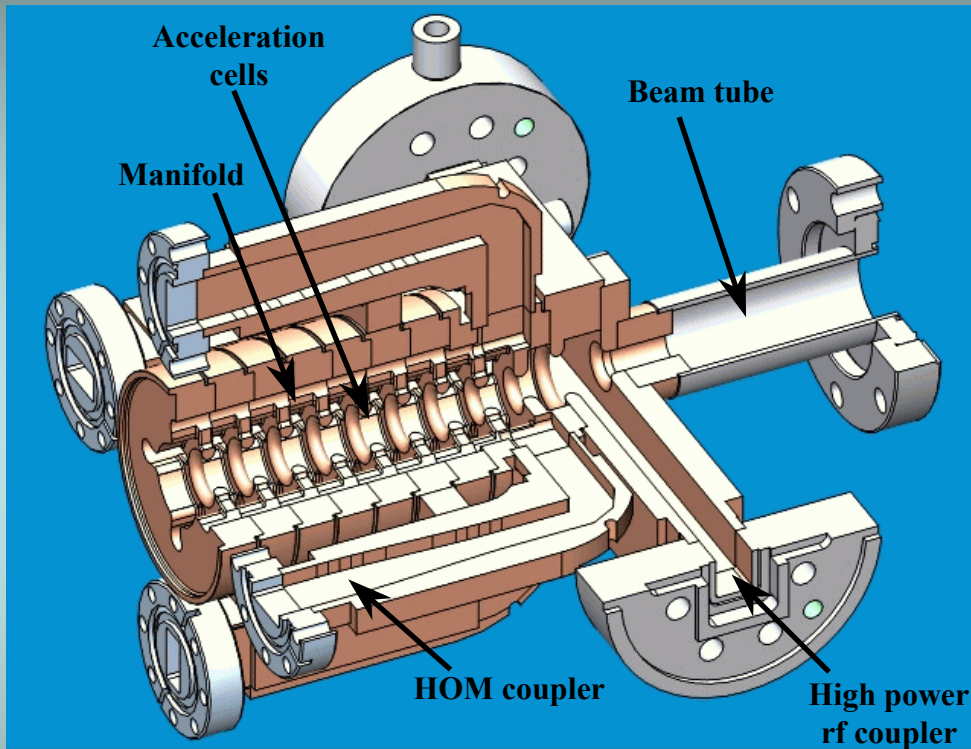

➤ In the NLC/JLC scenario we considered accelerating structures operating at room temperature and we accelerate bunches of charged particles at a frequency of 11.424 GHz.

➤ We envisaged accelerating 192 bunches; each bunch consisting of 10^{10} electron or positrons.

➤ Over a decade and a half of experience and the lessons learned in the design of the NLC will be invaluable in aiding the design of similar accelerators requiring high current, low-emittance beams.

➤ Application of damping scheme to the CLIC linear collider

➤ The wake-field is forced to partially decohere by detuning individual cells of each accelerating structure.

Review of General Methods of Wake-Field Damping

1. Strong Damping ($Q \sim 10$) \Rightarrow loss in the shunt impedance of the monopole mode.

a) Magnetic coupling – azimuthal slots (kidney slots)

b) Electric coupling – longitudinal slots

2. Resonant suppression

a) single frequency: $f_{\text{dipole}} = (n/2) f_{\text{bunch}}$ (zero-mode crossing)

b) multiple frequency, beat-note: $f_{\text{dipole1}} - f_{\text{dipole2}} = n f_{\text{bunch}}$

3. Non-resonant suppression – Detuning

a) Rectangular Kdn/df (kick factor weighted mode density) \Rightarrow sinc function wake

b) Gaussian $Kdn/df \Rightarrow$ Gaussian wake function

c) Truncation of Gaussian necessitates light damping in addition to detuning

d) Less sensitivity to frequency errors

e) Less impact on fundamental mode shunt impedance

General Aspects of Detuning

Gaussian density distributions

- Kick factor weighted density function: $Kdn/f \sim \exp[-(\omega-\omega_0)^2/2\sigma_\omega^2]$
- Ideally: $W(t) \sim \exp(-\sigma_\omega^2 t^2/2)$

- Advantages over other methods
 1. It is non-resonant and hence it does not freeze collider operation a bunch spacing other than the minimum bunch spacing.
 2. Wake-field decreases rapidly and monotonically
 3. It permits an error function interpolation with relatively sparse parameters

- Disadvantages
 1. Gaussian distribution is not limited and thus eventually it is truncated. This truncation gives rise to a sinc-like ($=\sin(x)/x$) wake which curtails the rapid fall-off at a level dependent on the truncation point
 2. The finite number of cells \Rightarrow finite number of modes \Rightarrow partial recoherence of wake-field starting at a time $t \sim 1/\delta f_{\max}$ (where δf_{\max} is the maximum separation of modes). Also, with damping there is another coherence point $1/\delta f_{\min}$ (where δf_{\min} is the minimum separation of modes, which lies in the centre of the Gaussian)

Application to CLIC Structure

- Bunch spacing is 6/7 cycles (depending on specific design) and this corresponds to 0.5003/0.5837 ns at a wavelength of 25 mm ($\omega_0/2\pi = 11.9917$ GHz).
- C.f. NLC/JLC in which $\omega_0/2\pi = 11.424$ GHz and the bunch spacing was 1.4/2.8 ns –i.e. CLIC is ~ 3 times smaller in bunch spacing
- Thus, it is clear the detuning must demand a more rapid fall-off in the wake-field.
- In practise the sigma of the Gaussian needs to be increased. Or, the bandwidth (which is effectively specified once the monopole group velocity has been assigned) is given in terms of less sigma.
- C.f. NLC/JLC in which we investigated a bandwidth in terms of sigma: 4/5 sigma. We also investigated various bandwidths (in the range >9 % to <12 %)
- For CLIC perhaps 10/12 sigma will be required? Beam dynamics simulations will clarify the exact requirements.

Band Partitioning

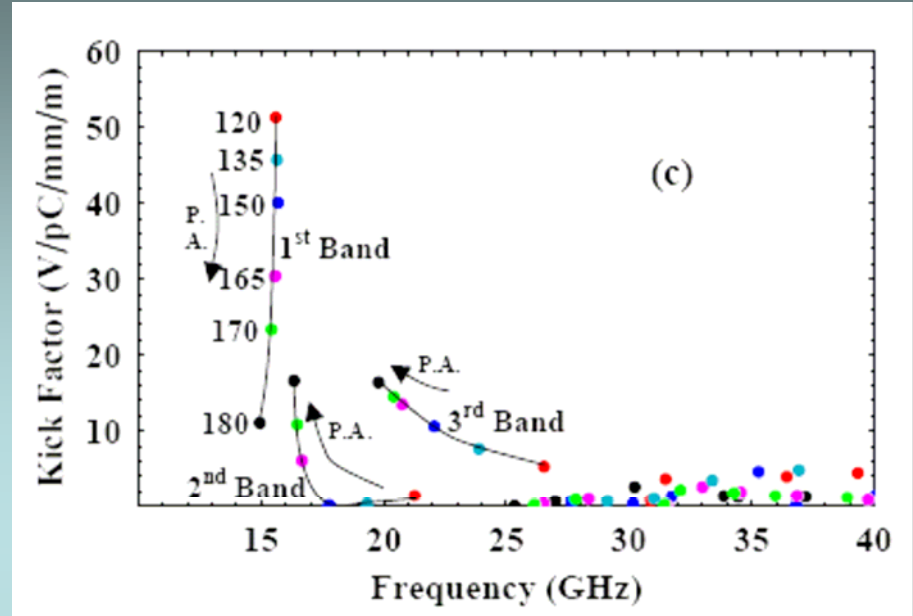
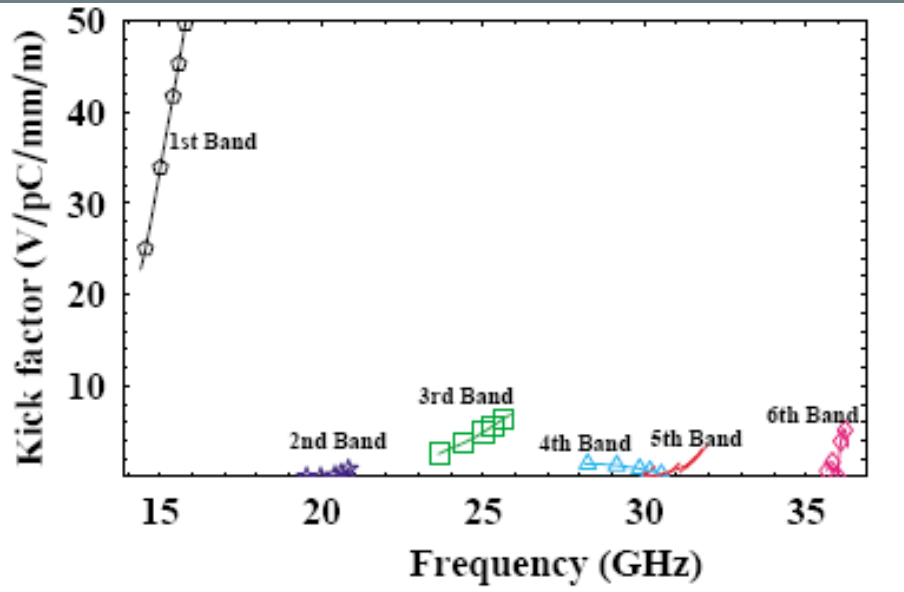

- Band partitioning of kick factors in 206 cell DDS1 X-band structure ($f_{acc}=11.424$ GHz). Largest kick factors located in the first band. Third and sixth bands although, an order of magnitude smaller, must also be detuned along with the 1st band.
- CLIC design $f_{acc} = 11.9917$ GHz shifts the dipole bands up in frequency.

- The partitioning of bands changes with phase advance. Choosing a phase advance close to π per cell results in a diminution of the kick factor of the first band and enhancement of the 2nd and 3rd bands. A similar effect occurs close to $\pi/2$.
- Kick factors versus phase advance for cells with an iris radius of ~ 4.23 mm.

Single Cell Dispersion Curves

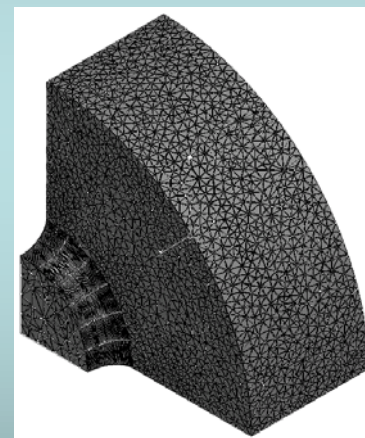
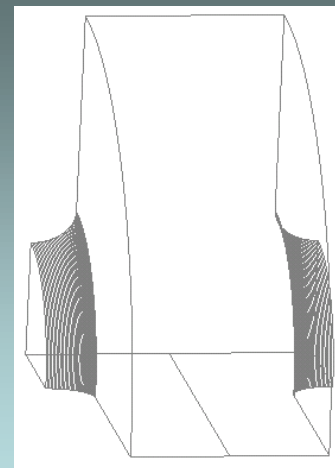
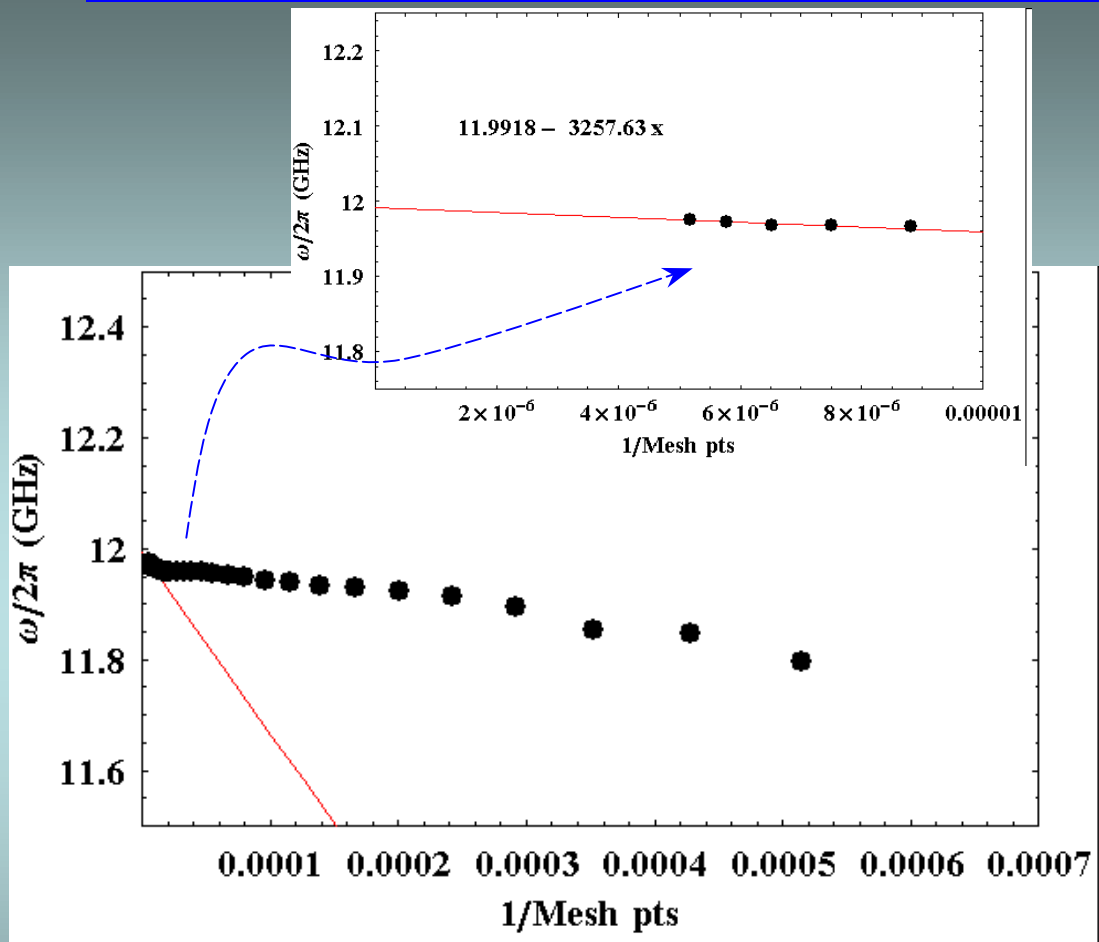

Cell 1: mesh

Cell 1: Accelerating mode convergence

- Vary cavity radius in order to obtain accelerating mode
- Vary ellipticity to fit group velocity
- Iterate until final solution obtain for monopole mode

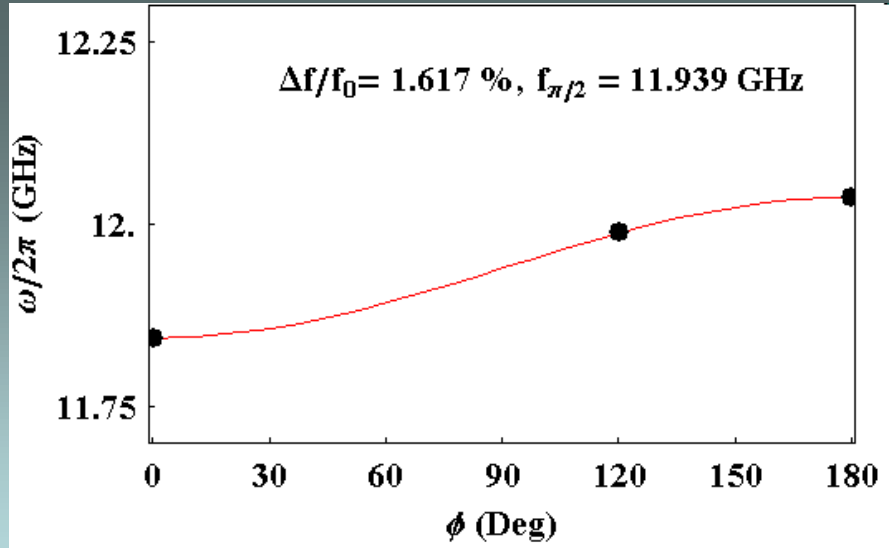

Use 0,Pi to fit to circuit model: $\frac{f_{\pi/2}}{\sqrt{1+\kappa \cos \phi}}$

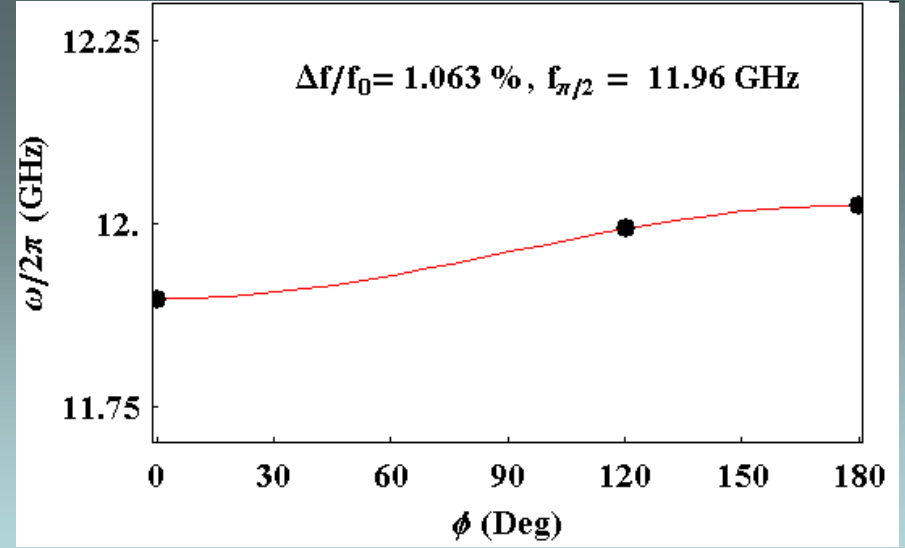

Use 0,Pi to fit to circuit model: $\frac{f_{\pi/2}}{\sqrt{1+\kappa \cos \phi}}$

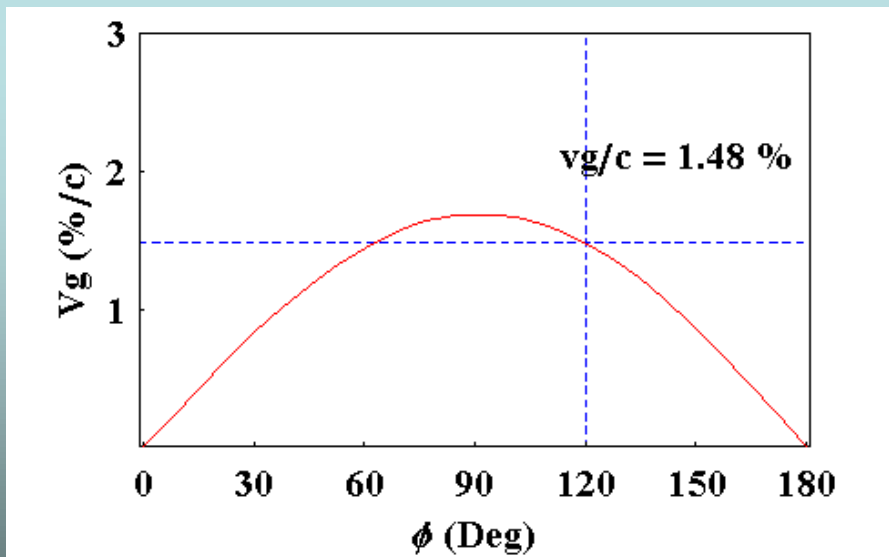

Monopole mode: cell 1

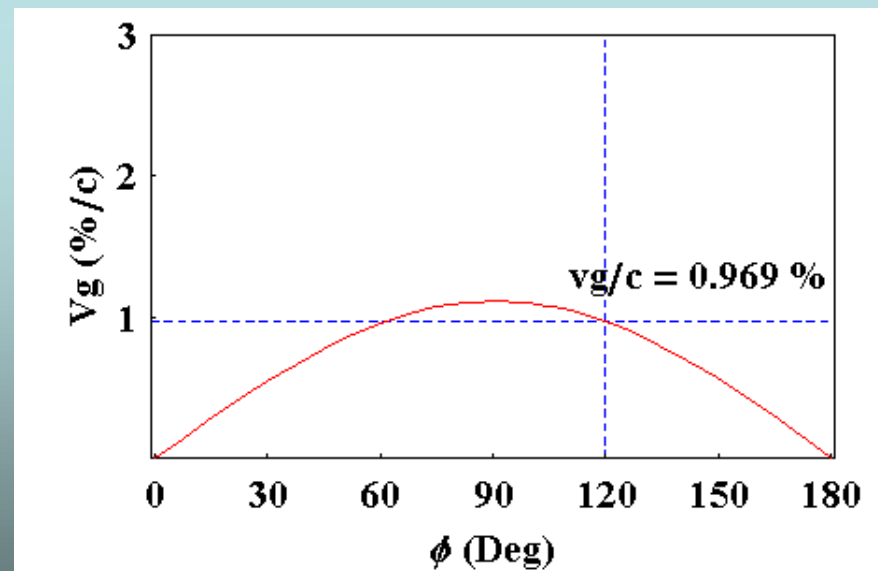

Monopole mode: cell 25

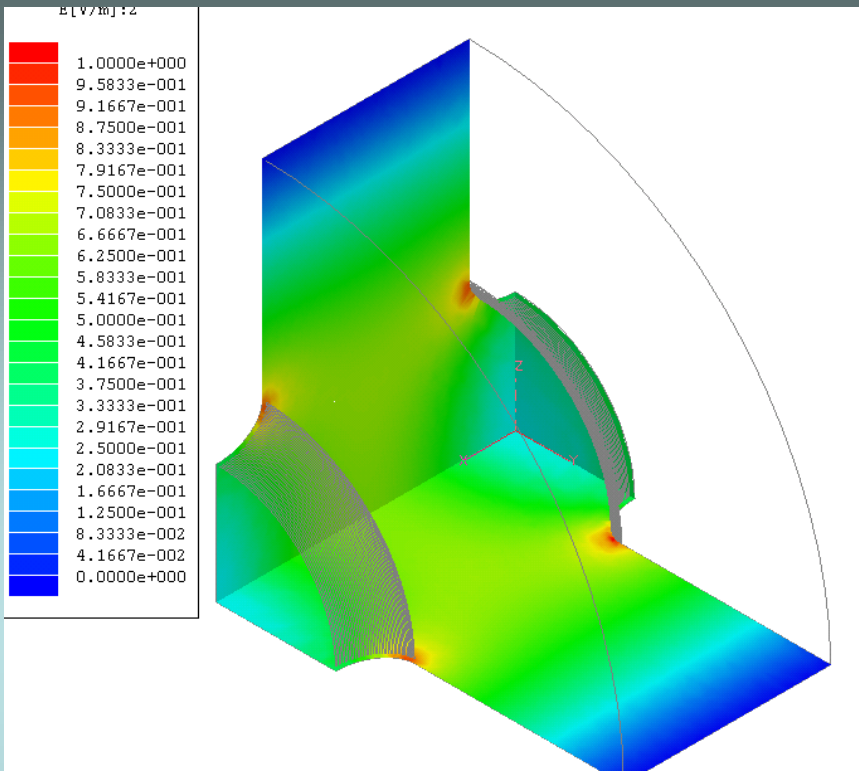

Monopole mode cell 1: E-field

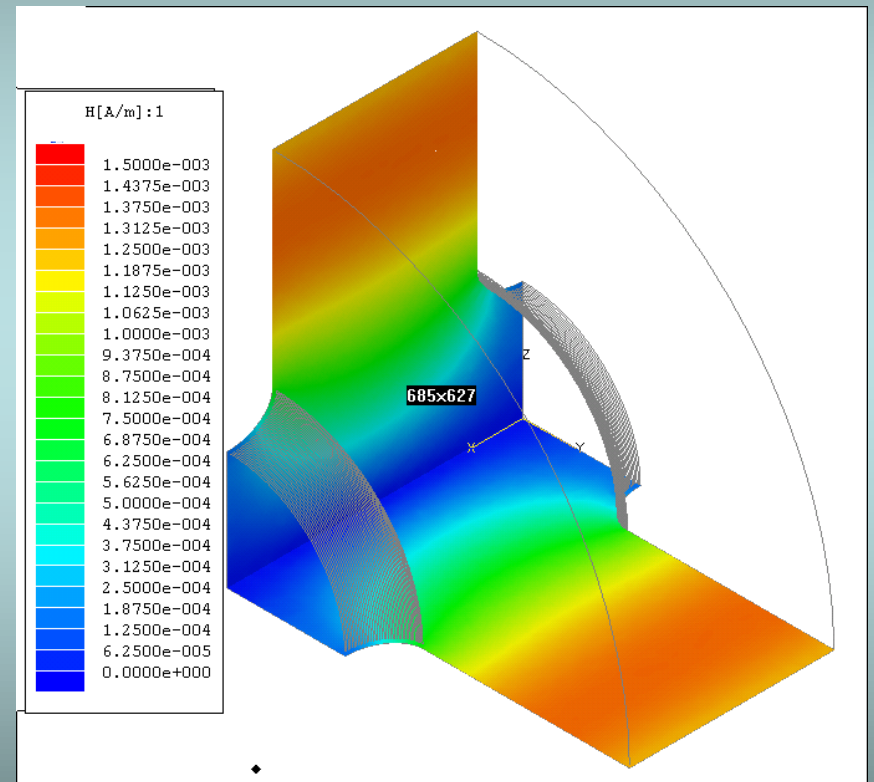

Monopole mode cell 1: H-field

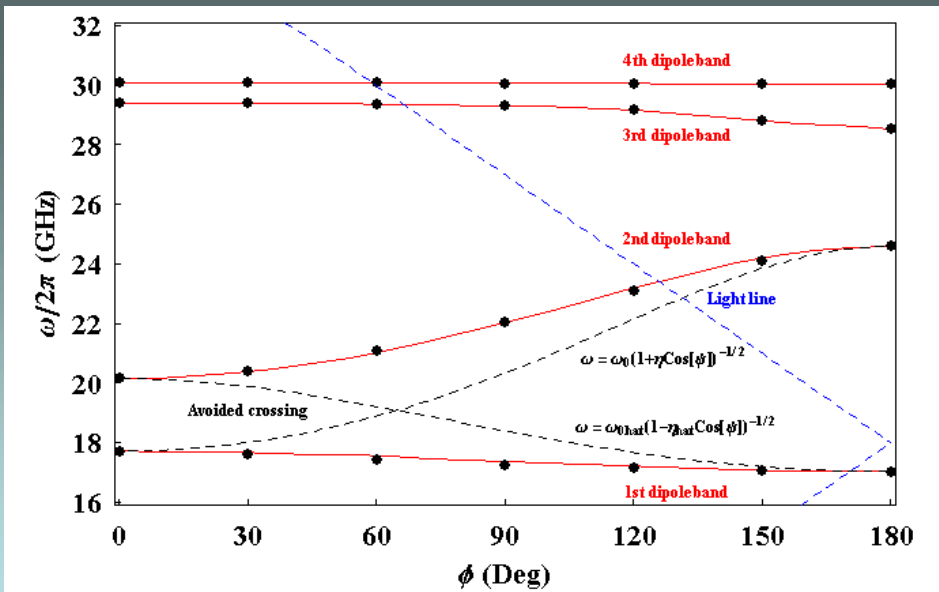

Dipole modes: Cell 1

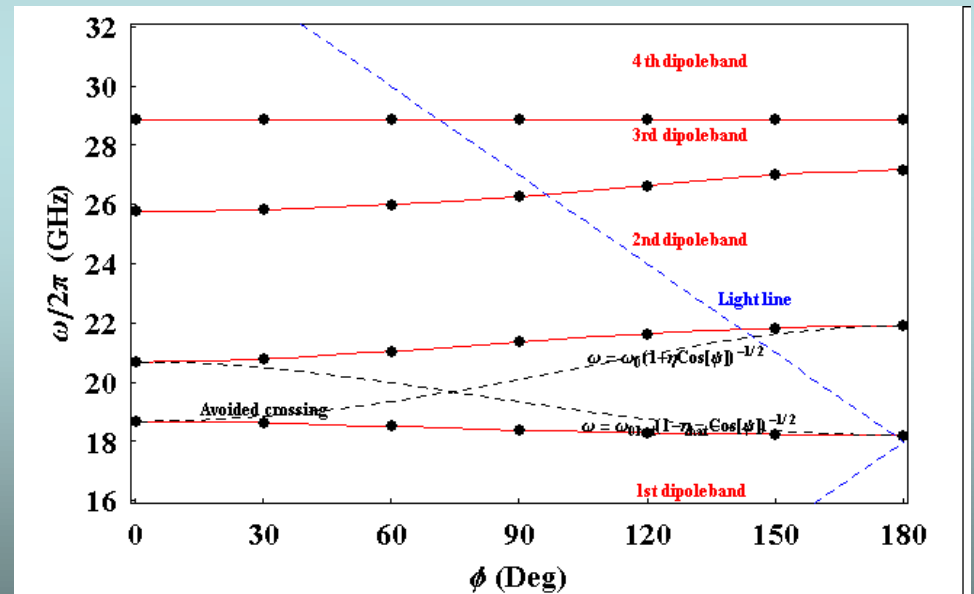

Dipole modes: Cell 25

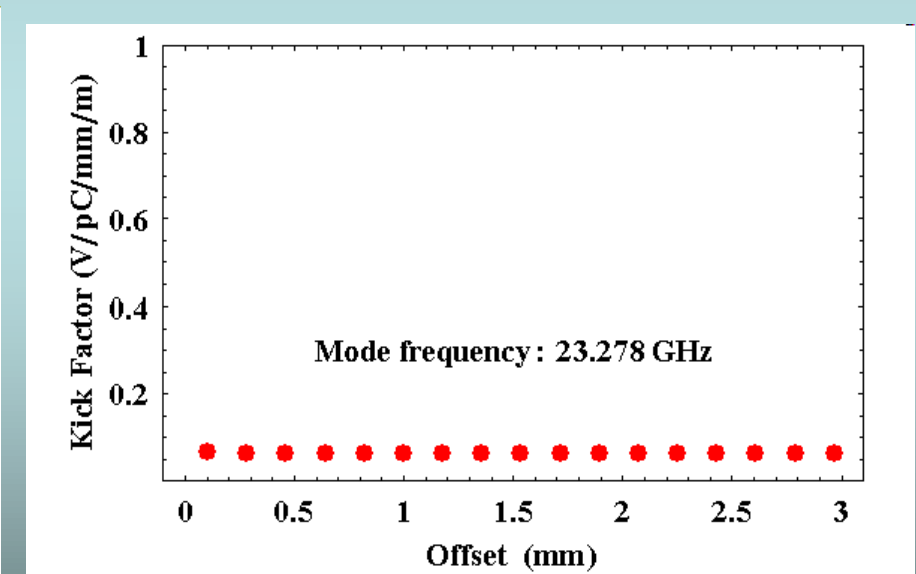
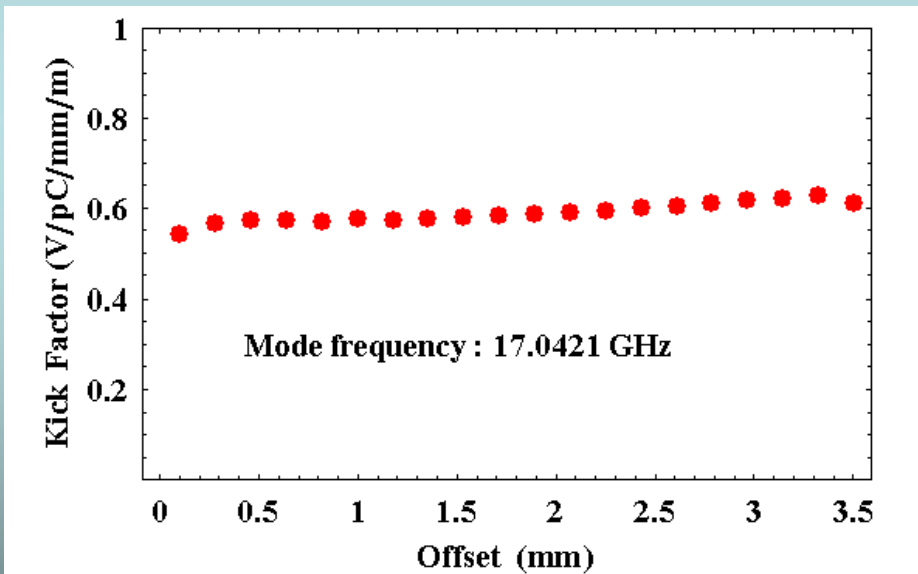
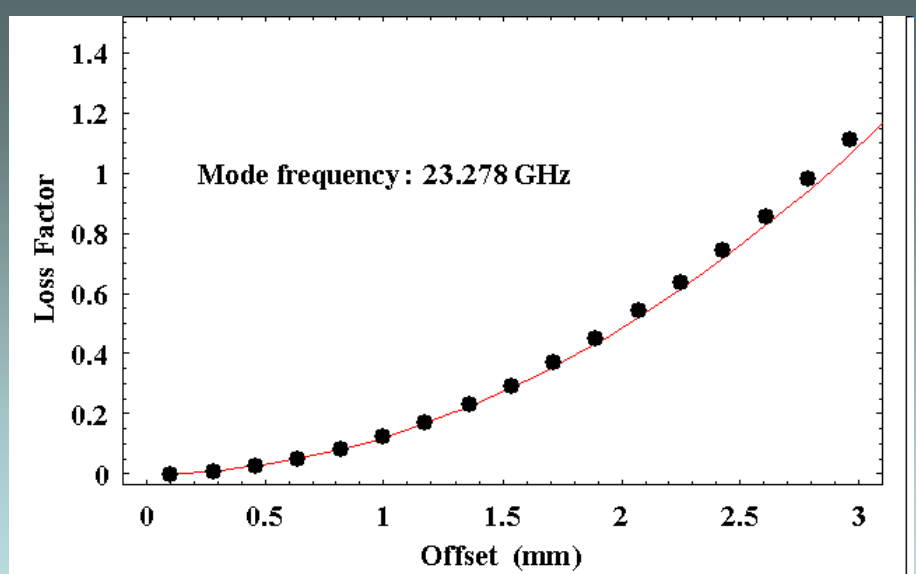
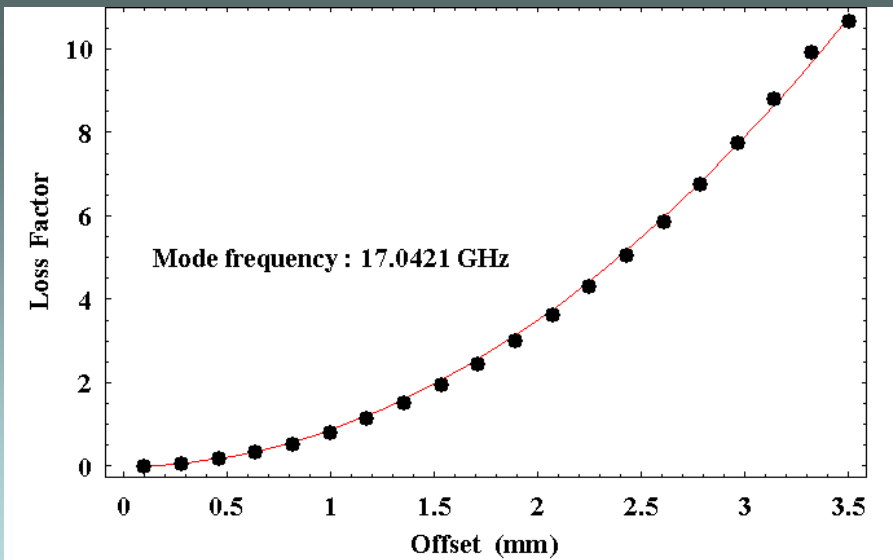

Cell 0: 1st Band Kick Factor
(17.0421 GHz, 0.61 V/pC/mm/m)

Cell 0: 2nd Band Kick Factor
(23.278 GHz, 0.065 V/pC/mm/m)

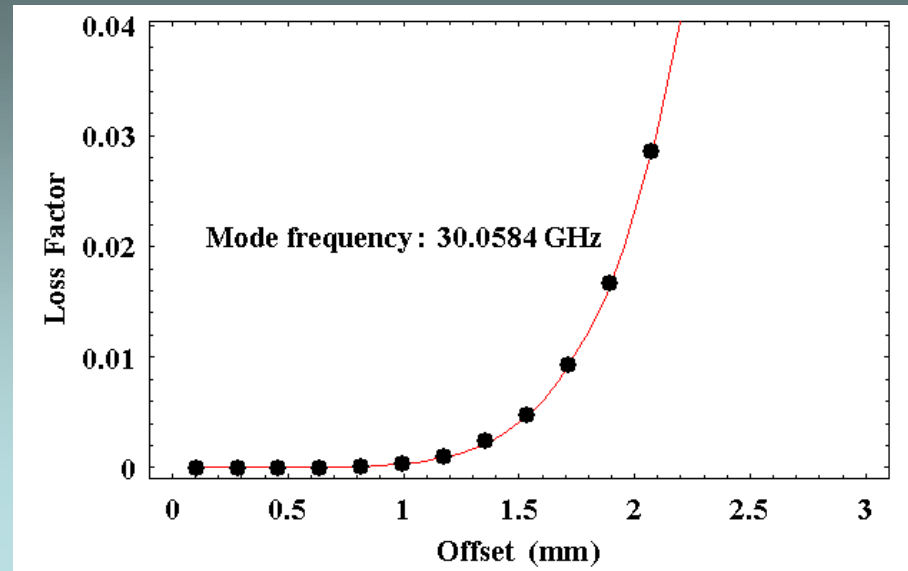
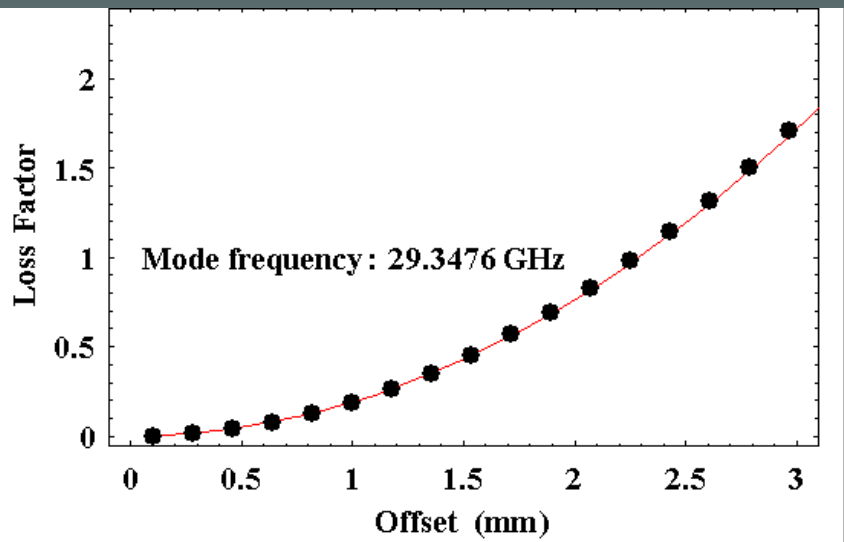

Cell 0: 4th Band Loss Factor
-Sextupole (0.00035r⁶)

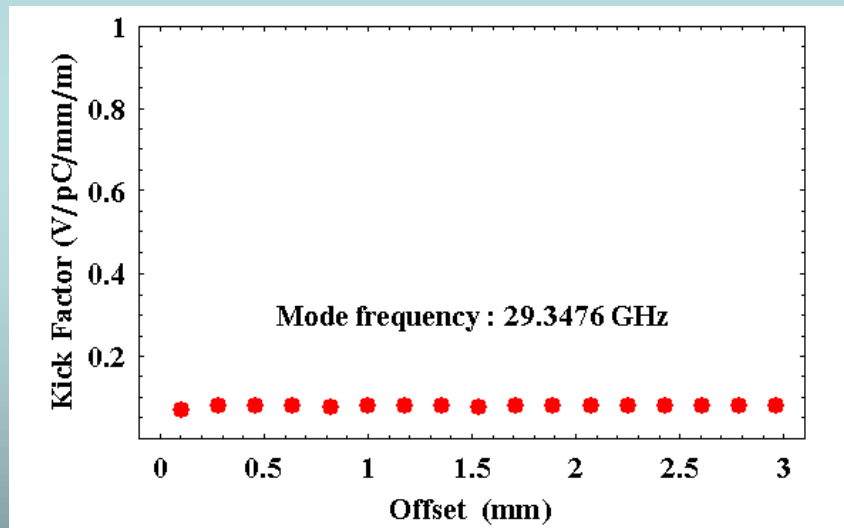

Cell 0: 3rd Band Kick Factor
(29.3476 GHz, 0.079 V/pC/mm/m)

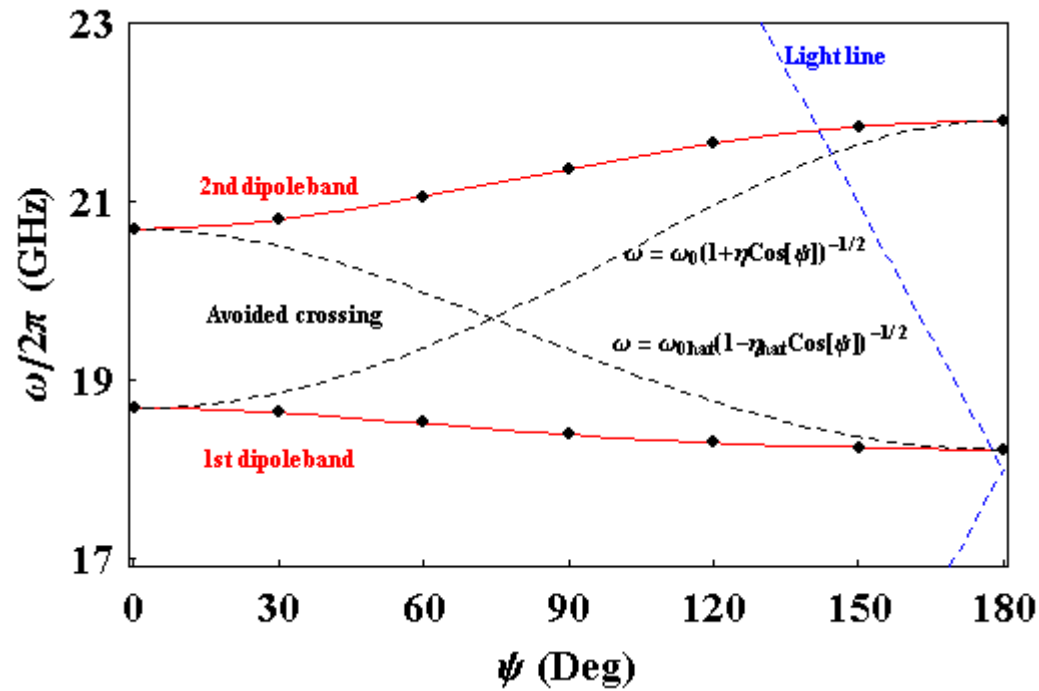

DIPOLE MODES: CELL 25

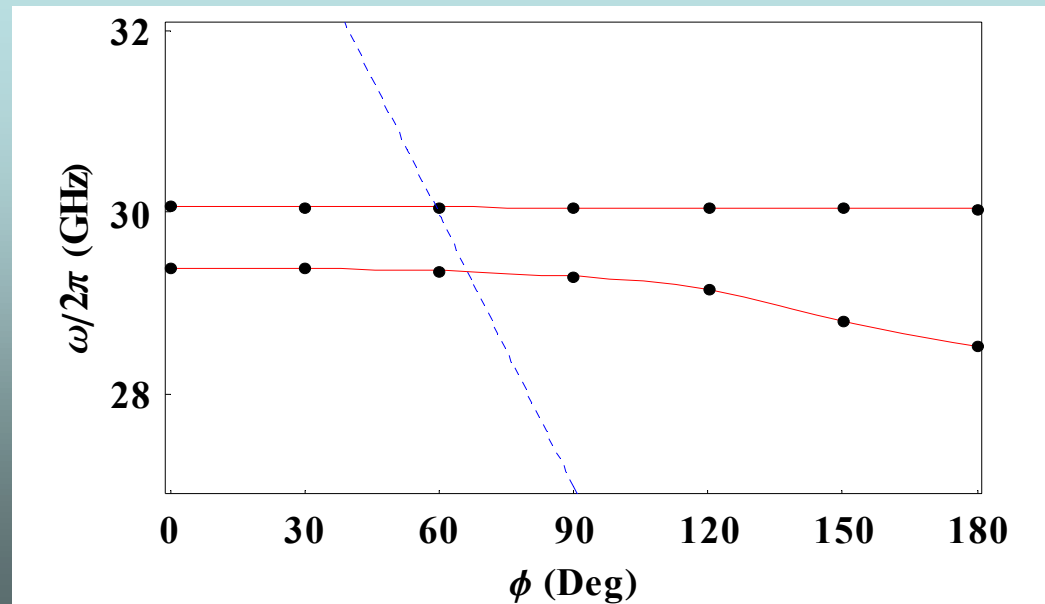

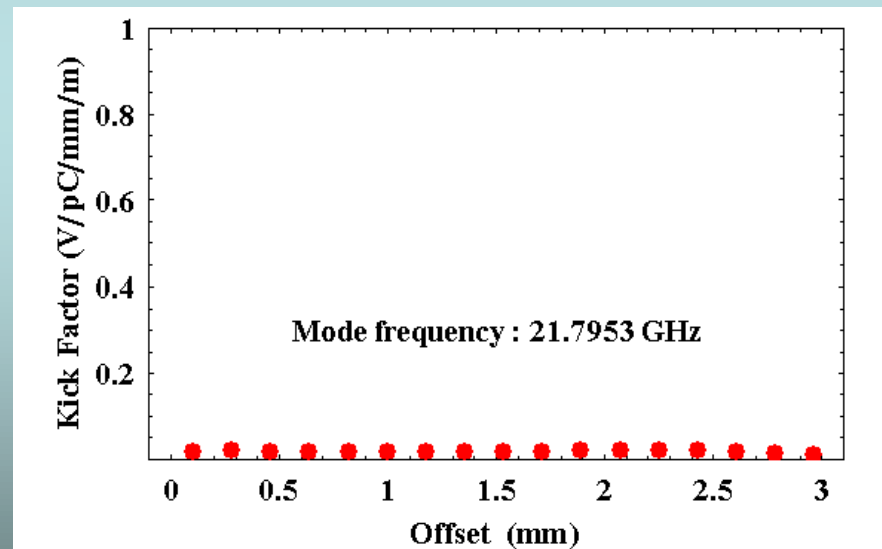
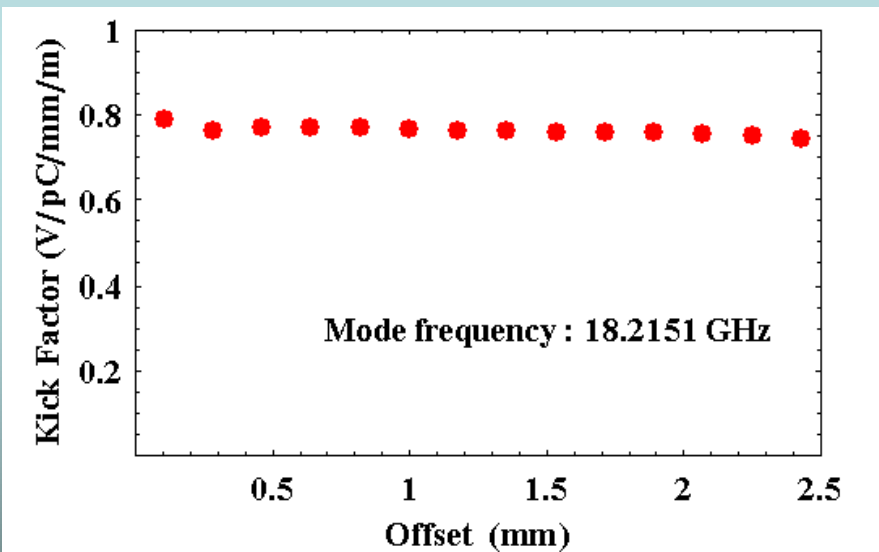
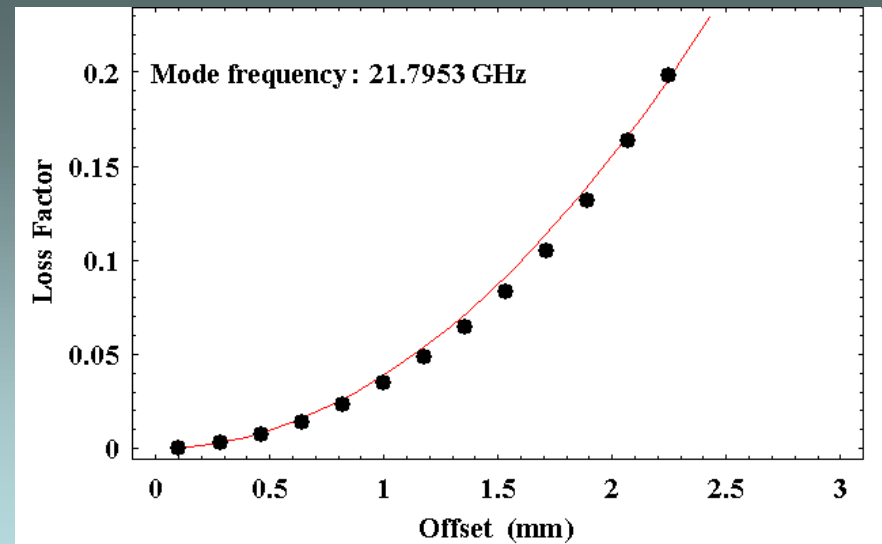
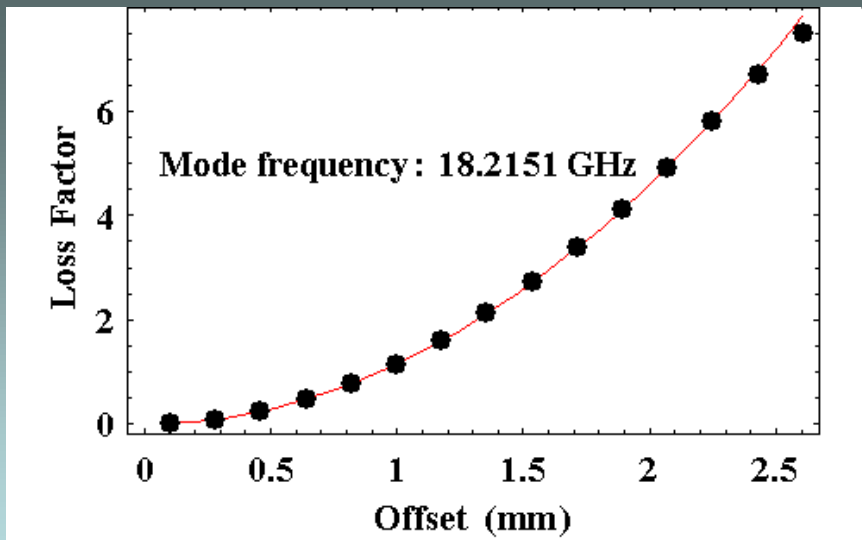

Cell 25: 1st Band Kick Factor
(18.2151 GHz, 0.79 V/pC/mm/m)

Cell 25: 2nd Band Kick Factor
(21.7953 GHz, 0.02 V/pC/mm/m)

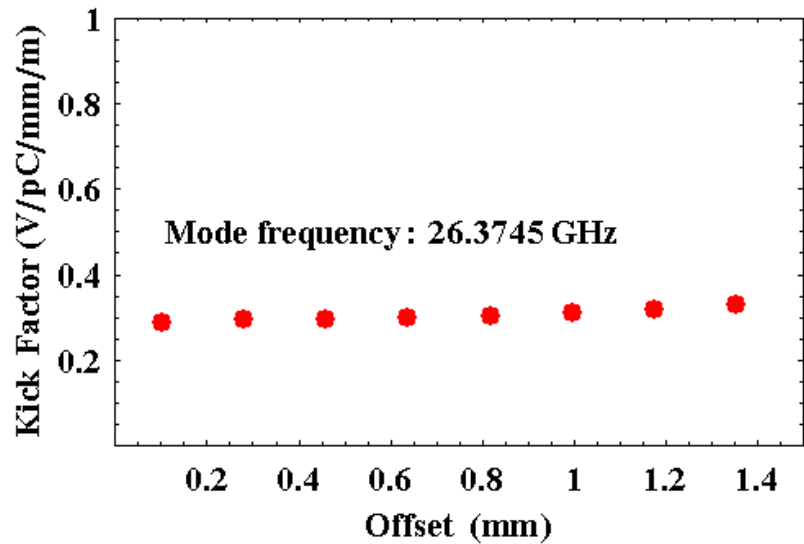
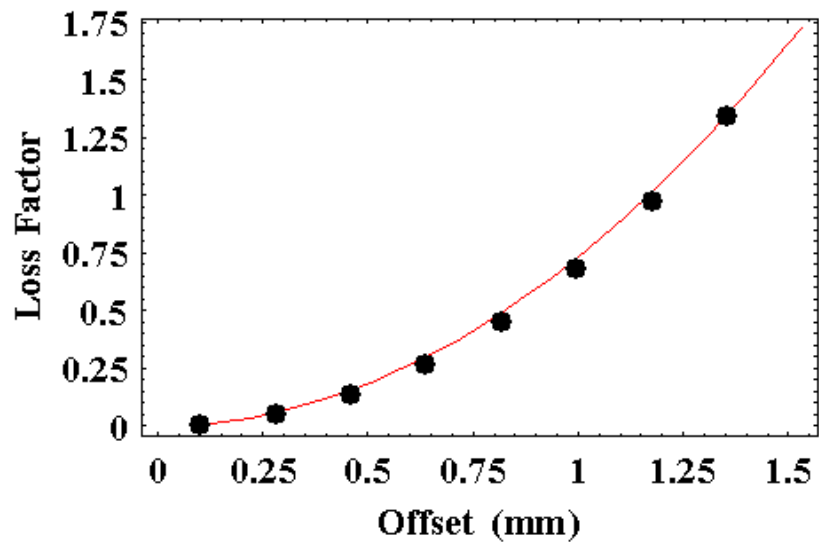

Cell 25: 3rd Band Kick Factor
(26.3745 GHz, 0.3 V/pC/mm/m)

A Two-Band Circuit Model of a Detuned Structure

- The nominal NLC design had 192 bunches spaced from their neighbours by 1.4 ns and this gives approximately 16 oscillations of the dipole modes between bunches. If we were to require the first trailing bunch to see 1/e of the wakefield generated by the driving bunch then a Q of ~ 50 (heavy damping) would be needed. Further, for the second design, for 195 bunches spaced by 2.8 ns there are 32 oscillations of the dipole mode frequency and 1/e damping required is ~ 100 .
- However, detuning the cell modes results in much more modest requirements on the local mode damping.
- Cell parameters (iris and cavity radius) follow an error function variation (Erf) and the wakefield falls off in a Gaussian fashion. The kick factor weighted density function (Kdn/df) is Gaussian in frequency the wakefield for short time scales is approximately given by the Fourier transform of the initial distribution. For short time scales the wakefield is approximately given by:

$$\tilde{W}(s) \approx \sum_n^{N_c} 2K_n \exp[-s\omega_n / (2Q_n)] \exp(i\omega_n s)$$

➤ where N_c is the total number of cells and K_n and ω_n are the uncoupled loss factor and wavenumber, respectively (both evaluated at the synchronous frequency for each cell n). Also a modal Q_n has been added to correspond to local damping. The actual wakefield that each bunch in the beam sees is given by the imaginary part of the above equation ($W(s) = \text{Im}\{\tilde{W}(s)\}$). However, it is useful to know the maximum excursion of the wakefield and for this purpose the envelope function is used; it is given by the absolute value of the above complex wake ($\hat{W}(s) = |\tilde{W}(s)|$).

➤ Secondly, again for short time scales:

$$W(s) = 2\bar{K} \sin(\bar{k}s) \exp[-(\bar{k}\sigma_{\delta f}s)^2/2]$$

➤ where the \bar{K} and $\bar{\omega} = \bar{k}c$ refer to the average uncoupled kick factor and synchronous frequency and $\sigma_{\delta f}$ is the sigma of the Gaussian distribution.

➤ However, the finite number of cells and the truncation of the Gaussian function results in a wakefield that starts to deviate from these approximate formulae. Thus, a coupled mode analysis or a complete finite element simulation is required to analyze the behavior of the wakefield.

Circuit Model of Damped and Detuned Structure

Brillioun Diagram for RDDS1 Cell 103

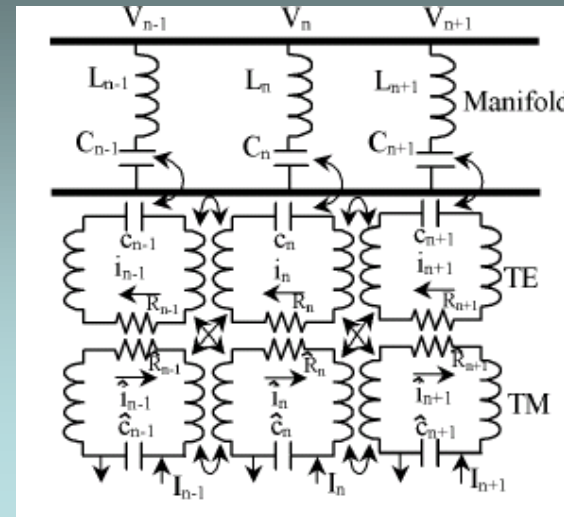
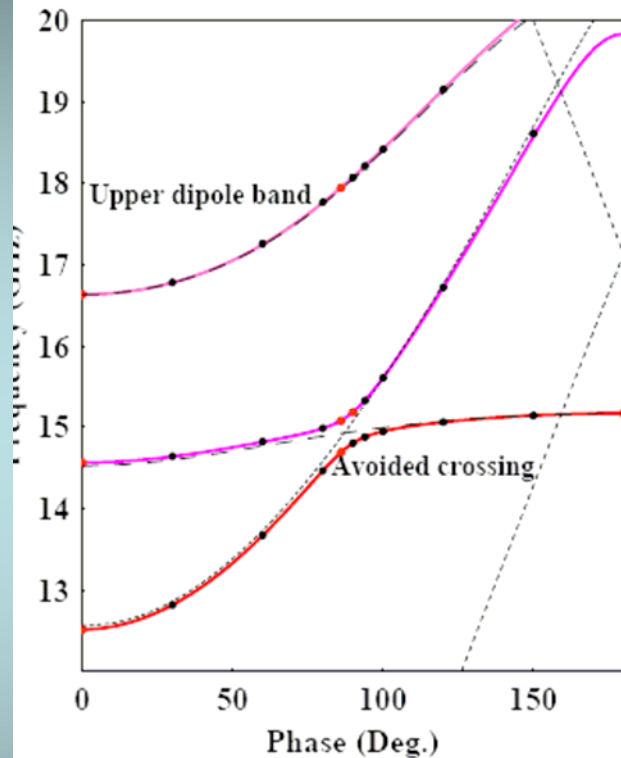

Three cells in the chain are illustrated. TM modes couple to the beam. Both TM and TE modes are excited and the coupling to the manifold is via TE modes. The manifold is modeled as a transmission line periodically loaded with L-C elements.

- Circuit model necessary for 206 cell DDS
- With a limited number of cells (~ 25) finite element/difference codes allow a complete determination of modes
- However, a circuit model is a useful tool in that both the implications of a new design and fabrication errors can be simulated in seconds

Circuit Model Equations

Coupling Between Manifold-Cell

$$V_n = -j \left(I_n / C_n + i_n \kappa_n / \sqrt{C_n c_n} \right) / \omega$$

$$v_n = -j \left(i_n / c_n + I_n \kappa_n / \sqrt{C_n c_n} \right) / \omega$$

Matrix Elements

$$R_{nn} = -2 \cos \phi_n, \quad R_{nn\pm 1} = 1$$

$$\cos \phi_n = \cos \phi_{0n} - \alpha_n \left(\pi L / c \right)^2 F_n^2 / \left(F_n^2 - f^2 \right) \operatorname{sinc} \phi_{0n}$$

$$\phi_{0n} = \left(2\pi L / c \right) \sqrt{f^2 - F_{cn}^2}$$

$$H_{nn} = 1 / f_n^2 + \Gamma_n^2 / \alpha_n / \left(F_n^2 - f^2 \right)$$

$$H_{nn\pm 1} = \eta_{n\pm 1/2} / \left(2f_n f_{n\pm 1} \right)$$

$$H_{nn\pm 1} = \pm \eta_{x,n\pm 1/2} / \left(2\hat{f}_n \hat{f}_{n\pm 1} \right)$$

$$\hat{H}_{nn} = 1 / \hat{f}_n^2, \quad \hat{H}_{nn\pm 1} = -\hat{\eta}_{n\pm 1/2} / \left(2\hat{f}_n \hat{f}_{n\pm 1} \right)$$

$$G_{nn} = \Gamma_n \left(\pi L / c \right)^2 F_n^2 / \left(F_n^2 - f^2 \right) \sqrt{2 \operatorname{sinc} \phi_{0n}}$$

Network Equations in Matrix Form:

$$RA = Ga$$

$$\left(H - 1/f^2 \right) a + H_x \hat{a} = GA \left(= GR^{-1} Ga \right)$$

$$\left(\hat{H} - 1/f^2 \right) \hat{a} + H_x^t = B/f^2$$

- In the 9-parameter model each parameter is determined from MAFIA or Omega3 simulations to produce Brillouin diagrams for a limited number of fiducial cells.
- The remaining cells are obtained by interpolation and non-linear error function (Erf) fits.

Determination of Parameters

$$\left[\underbrace{\left(\frac{1 + \eta \cos \psi}{f_0^2} + \frac{\Gamma^2}{\alpha(F^2 - f^2)} - \frac{1}{f^2} \right)}_{\text{TE Cell Mode}} \underbrace{\left(\frac{1 - \hat{\eta} \cos \psi}{\hat{f}_0^2} - \frac{1}{f^2} \right)}_{\text{TM Cell Mode}} - \underbrace{\frac{\bar{\eta}^2}{f_0^2 \hat{f}_0^2} \sin^2 \psi}_{\text{TE-TM Coupling}} \right] \underbrace{(\cos \psi - \cos \phi)}_{\text{Manifold Mode}} = \underbrace{\left(\frac{F^2}{F^2 - f^2} \right)^2 \left(\frac{\pi L}{c} \right)^2 \left(\frac{1 - \hat{\eta} \cos \psi}{\hat{f}_0^2} - \frac{1}{f^2} \right)}_{\text{Coupling to Manifold}} \sin \phi_0$$

- The parameters are obtained from finite element/difference simulations of single cells and fitting the above equation to the Brillouin curves.
- There are potentially 9 (often reduced to 8) parameters necessary to be determined from infinite periodic boundary conditions. Five are associated with the cells and 4 with the manifold.
- Setting $\Gamma = 0$ and we are left with three equations: the manifold equation given by $\cos \psi = \cos \phi$ and the coupled two-band dipole model mode.

Spectral Function Method

Recall the circuit equations for the TE and TM cell amplitudes in matrix form:

$$\begin{pmatrix} \hat{H} & H_x^t \\ H_x & H-GR^{-1}G \end{pmatrix} \begin{pmatrix} \hat{a} \\ a \end{pmatrix} = \frac{1}{f^2} \begin{pmatrix} \hat{a} \\ a \end{pmatrix} = \frac{1}{f^2} \begin{pmatrix} B \\ 0 \end{pmatrix}$$

Here, H_x is a tridiagonal matrix with vanishing diagonal elements which describes the TE-TM cross coupling, R which describes propagation in the manifold is also tridiagonal and G , which describes the TE coupling of the cells to the manifold is diagonal. The elements of the column vectors are themselves N element vectors.

The above readily lends itself to a further condensed form:

$$\bar{H}\bar{a} - f^{-2}\bar{a} = f^{-2}\bar{B}$$

The drive beam represented by the N component vector B couples to the TM wave only:

$$B_n = \sqrt{4\pi f_s^n / c} K_s^n L \exp[-j2\pi(L/c)n]$$

where L is the periodicity of the cell. The transverse wake function (transverse potential per unit length) for a particle traveling behind a velocity c particle (per unit drive charge per unit witness charge) is written:

$$W(s) = \int Z(f - j\epsilon) \exp\left[\left(2\pi j s / c\right)(f - j\epsilon)\right] df$$

where ϵ is an infinitesimal quantity (required to ensure the integral is performed away from the real axis) and the wake impedance is given by:

$$Z(f) = \pi^{-1} \sum_{n,m} \sqrt{K_s^n K_s^m} \exp\left[\left(2\pi j L / c\right)f(n-m)\right] \tilde{H}_{nm}$$

with the $2N \times 2N$ matrix given by:

$$\tilde{H} = \bar{H} \left(1 - f^2 \bar{H}\right)^{-1}$$

Because $W(s)$ is real we require $Z(f) = Z^*(-f^*)$ for f in the lower half plane. Due to the presence of the manifold we find that Z is discontinuous across the real axis and thus cuts are introduced to ensure that Z remains single valued on the physical sheet. It also an even function of f in the complex plane $Z(f) = Z(-f)$.

Wake Function Regimes

1. Zero Damping (Pure Detuning)

$$W(s) = \theta(s) \sum 2K_p \sin(k_p s)$$

Here s is the distance behind the bunch, $\theta(s)$ is the unit step function and

$$k_p = \frac{2\pi f_p}{c}$$

2. Weak Damping

$$W(s) = \theta(s) \sum 2K_p \sin(k_p s) \exp\left(-\frac{k_p}{2Q_p} s\right)$$

3. Strong and Moderate Damping

$$W(s) = \theta(s) \int_{\text{cut}} S_p(f) \sin(k_p s) df$$

The **spectral function technique** covers a broad class of regimes:
1 and 2 are special cases of 3.

Interleaving of Cell Frequencies

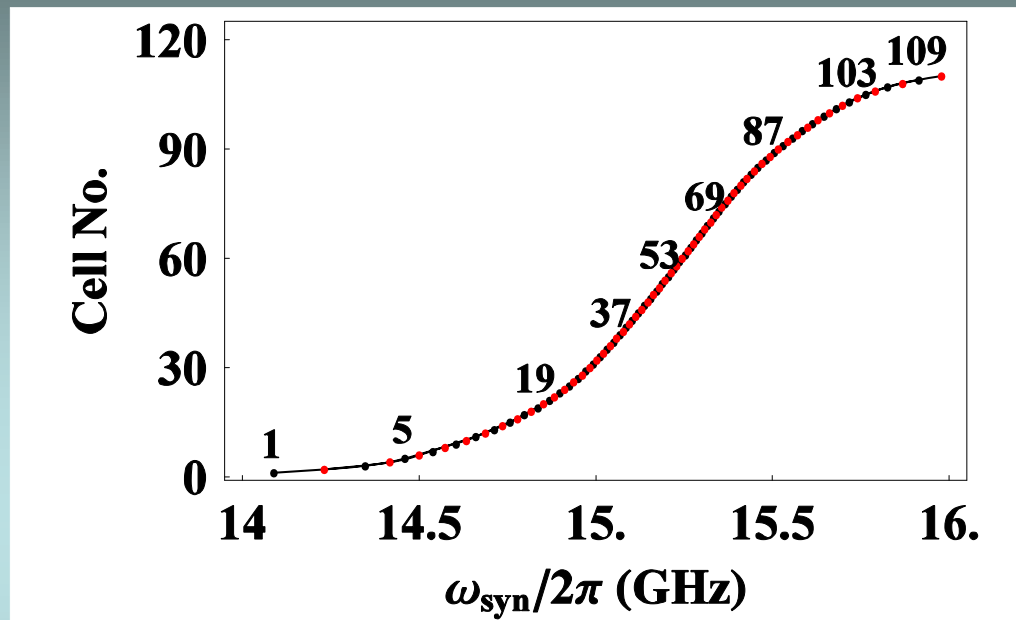

- The cells effectively sample the prescribed Gaussian distribution.
- As there are a finite number of cells then eventually the modes add up constructively and the wake-field re-coheres at ($t \sim 1/f_{\text{min}}$).
- We can fabricate structures such that neighbouring structures are interleaved to reduce the magnitude of the re-coherence peak and to push it further out from the location of the first trailing bunch

Wake-Field of Two-Fold Interleaved Structure

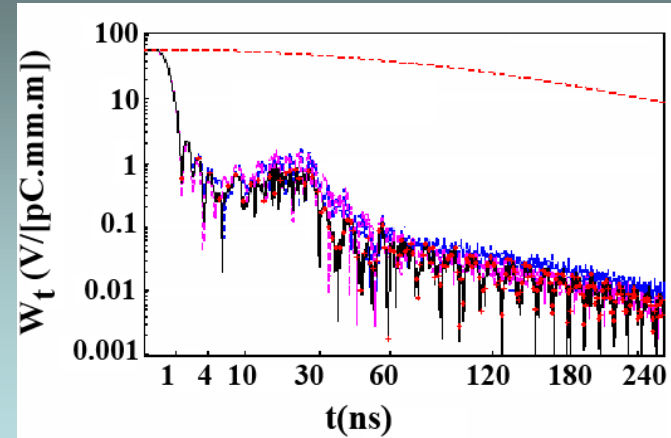
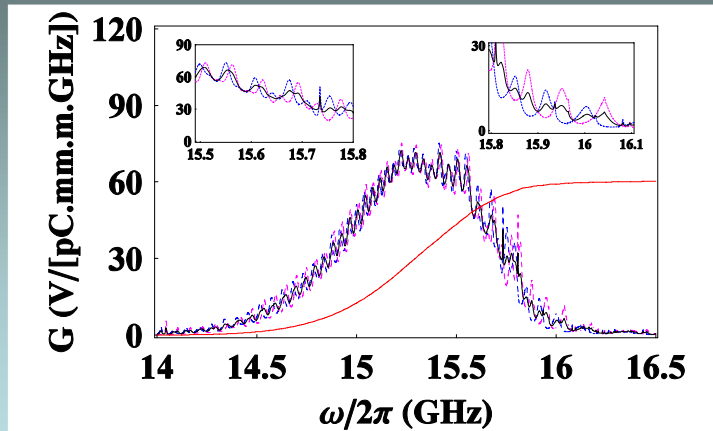

Spectral function and the wake-function for H60VG4SL17A

- Spectral function and the inverse Fourier transform thereof for both individual and two-fold interleaved structures
- The method of interleaving can be a straightforward positioning of each cell at the mid-point of the uncoupled single-cell of its neighbour or, the synchronous frequencies are chosen according to the location of the coupled frequencies. Clearly, the latter method is optimum.
- The method display above used the mid-point of the separation of the cell synchronous frequencies. It was chosen in order to make a rapid experimental comparison with the predicted wake-field.
- The amplitude of the re-coherence peak can be reduced with further optimisation.

Measurement of Wake-Field of Interleaved H60VG4SL17A/B

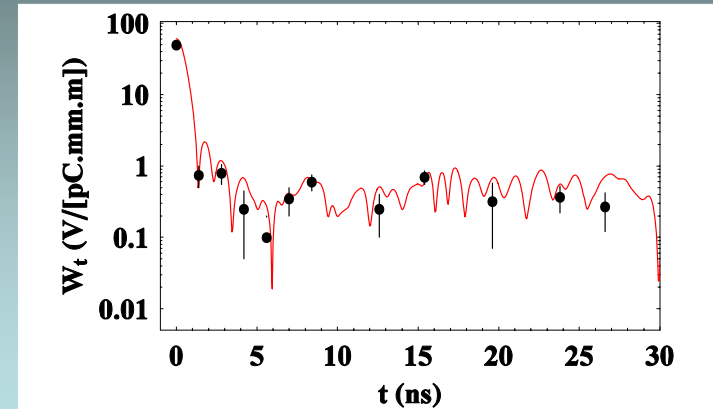
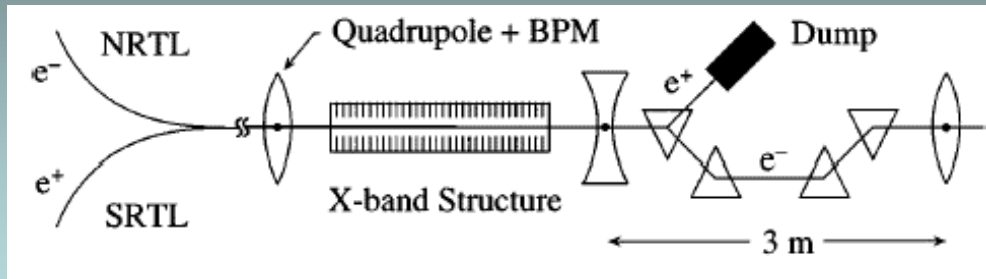

- Shown on the left is the experimental set-up ASSET. Indicated on the right is both the measured (dot) and the predicted wake-field for the two-fold interleaved structure H60VG4SL17A.
- The experimental result indicates that the wake-field is well-predicted from the circuit model and the fabrication errors do not appreciably affect the wake-field (the minimum mode spacing ~ 10 MHz)

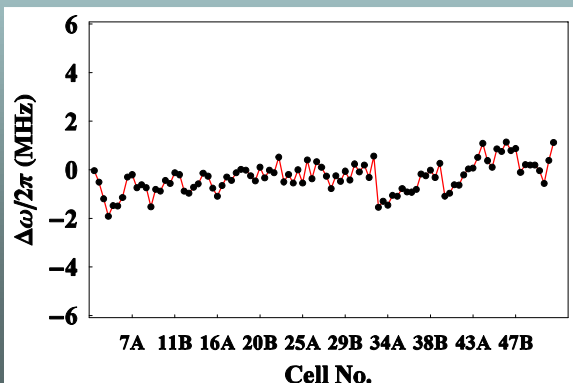

- Adjacent are the deviation of the dipole mode frequencies from their design values for all cells of H60VG4SL17A/B. The RMS frequency of the frequency deviation is ~ 0.6 MHz.

Beam Dynamics and Relaxed Tolerances

- Emittance we incorporate random frequency errors into a set of 50 accelerating structures and randomly distribute them along the entire linac. In all cases the beam is injected into the linac with an offset of approximately one σ_y , with an energy of 5 GeV and the progress of the beam is monitored as it traverses the entire linac.
- The final emittance dilution, together with the rms of the sum wake-field, is illustrated for small changes in the bunch spacing.
- The particular simulation illustrated includes a cell-to-cell frequency error with an rms value of 20 MHz. We chose this rather large frequency error in order to gain an understanding of the impact of relaxed

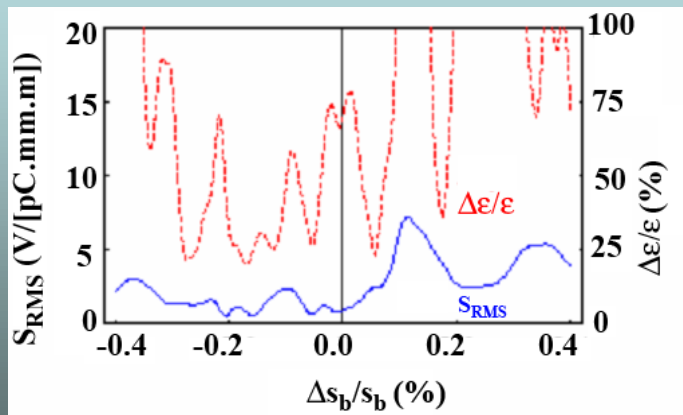

- Emittance dilution (illustrated by the red dashed curve) versus the percentage change in the bunch spacing.
- Also shown is the corresponding rms of the sum wake-field (by the solid blue curve).