

# CLIC main linac accelerating structure optimization.

20.06.2007  
Alexej Grudiev

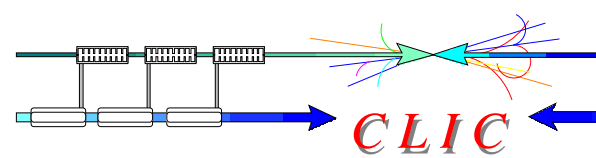

- Optimization of CLIC main linac accelerating structure
  - Optimization procedure
  - Optimization constraints
  - Optimization results
- Design of X-band accelerating structure for CLIC
  - The optimum structure
  - Modification of T53vg3MC (NLCTA test structure)

# Optimization procedure

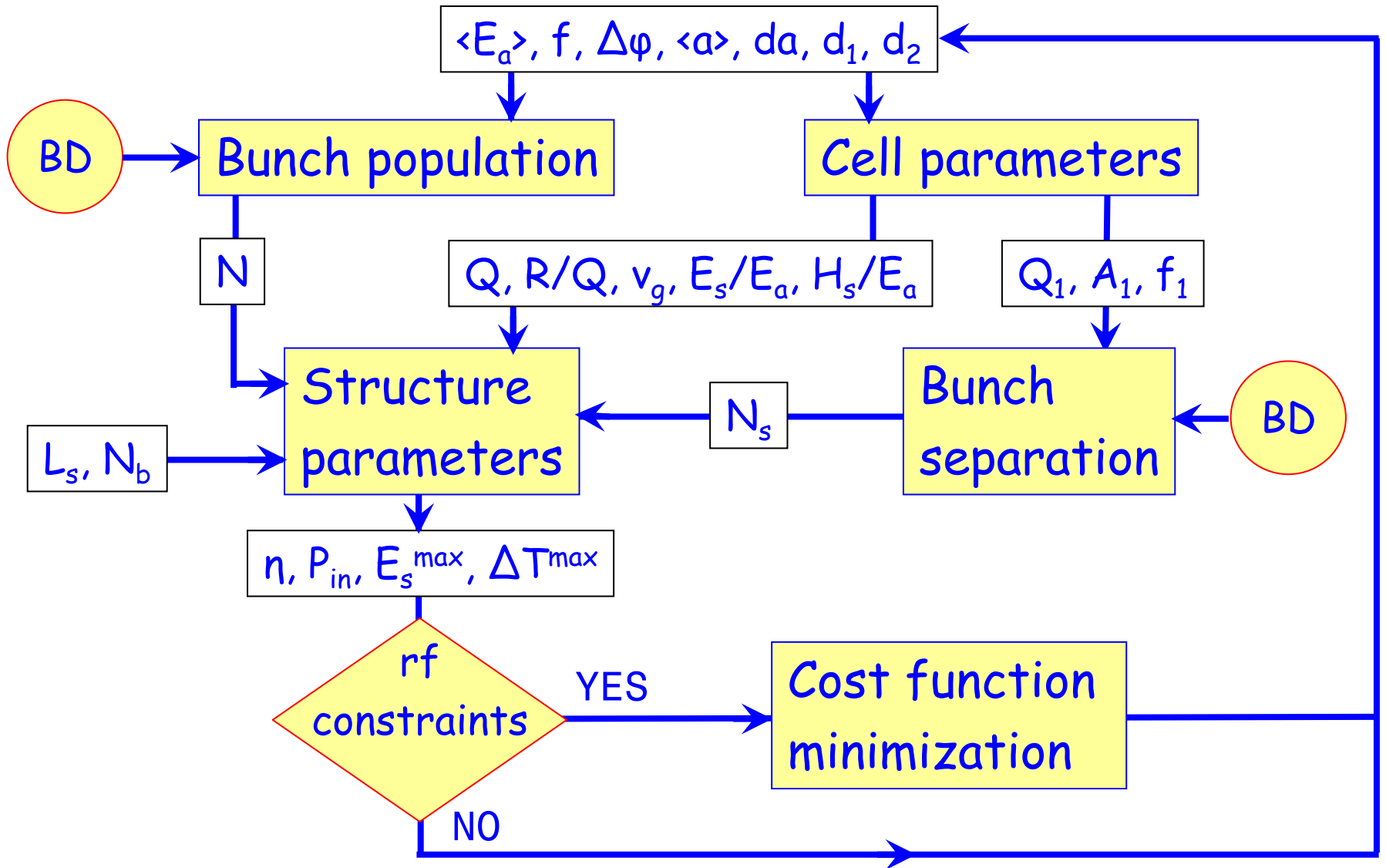

# Cell parameter calculation

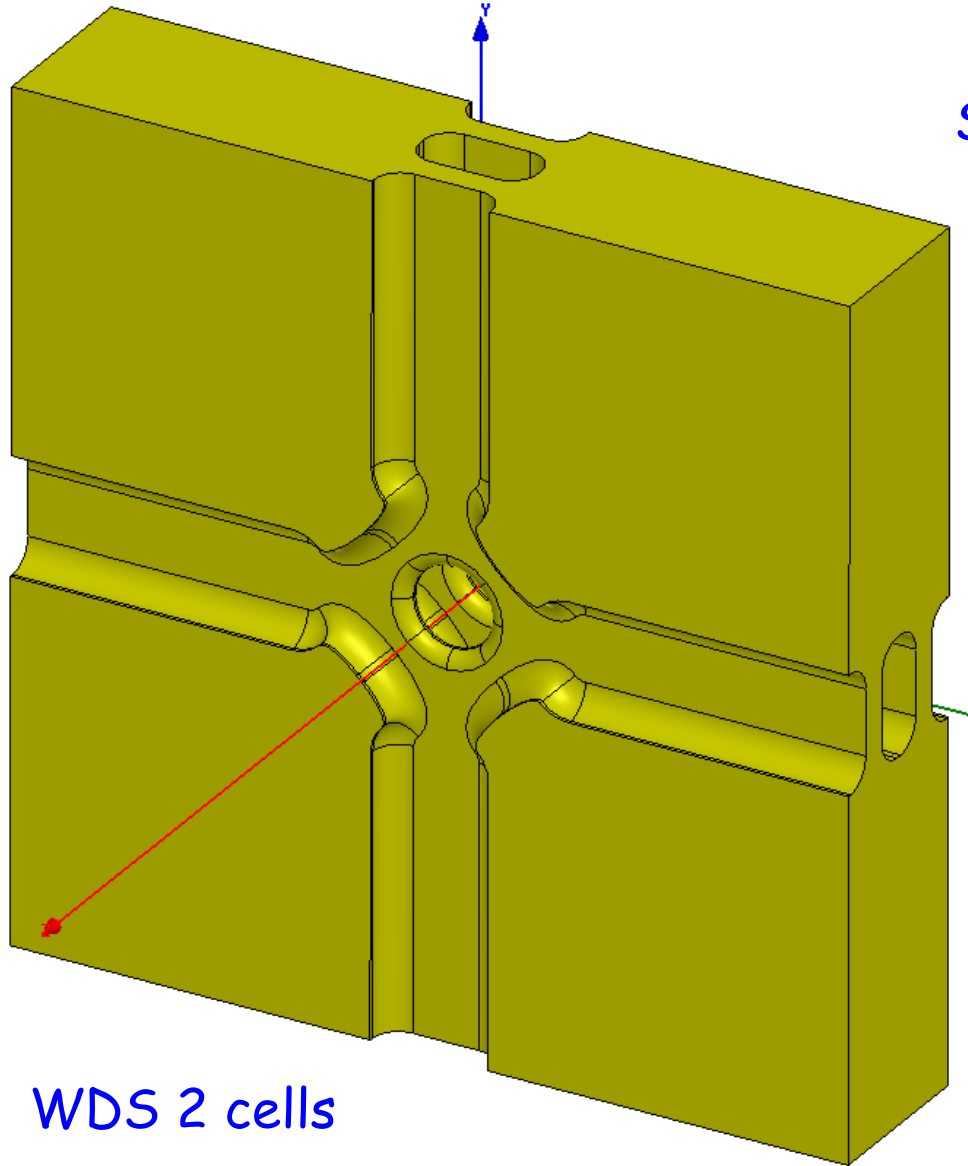
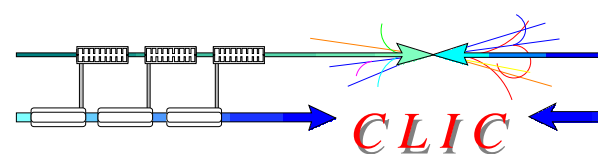

## Single cell parameter interpolation

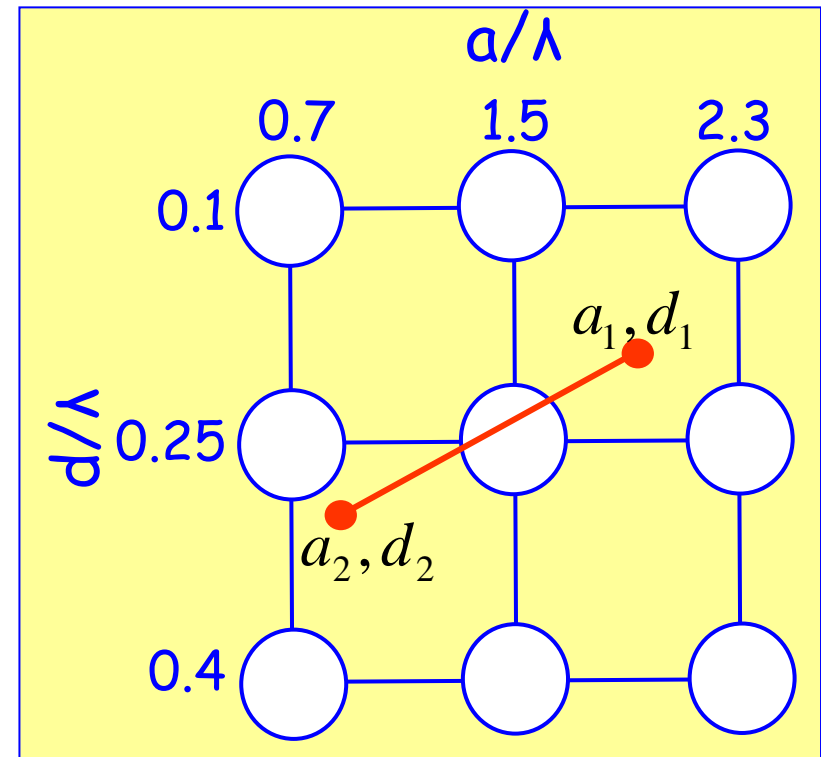

# Structure parameter calculation

CLIC

Dipole mode:

$$W_t = \sum_{i=1}^{N_{cells}} A'_{1i} e^{-\frac{\omega_{1i}t}{2Q_{1i}}} \sin(\omega_{1i}t)$$



$$N_s$$



$$I$$



$$N$$

Fundamental mode:

$$\frac{dP}{dz} = -\frac{\omega}{Qv_g} P - \sqrt{\frac{\omega R'}{v_g Q}} I P^{\frac{1}{2}}$$



$$P(z)$$



$$n, P_{in}, E_s^{\max}, \Delta T^{\max}$$

# Structure bandwidth model

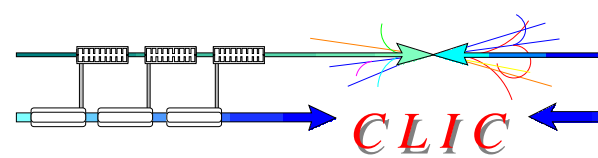

$$t_r = (\delta f)^{-1} - \text{rise time}$$

$$t_p = t_f + t_b \Rightarrow t_p' = t_f + t_b + t_r$$

$$\eta \Rightarrow \eta'$$

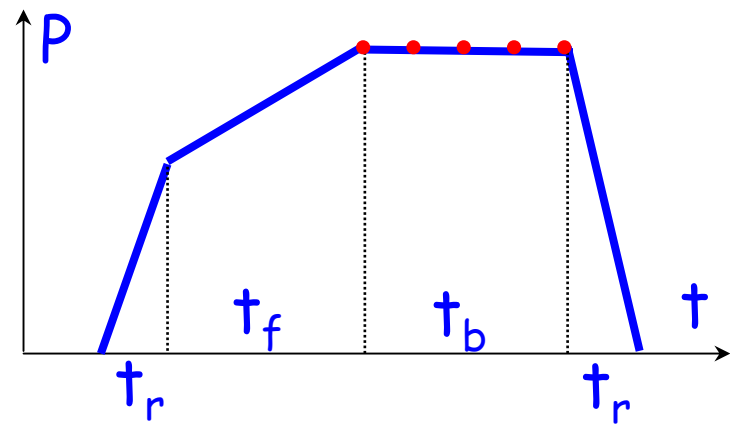
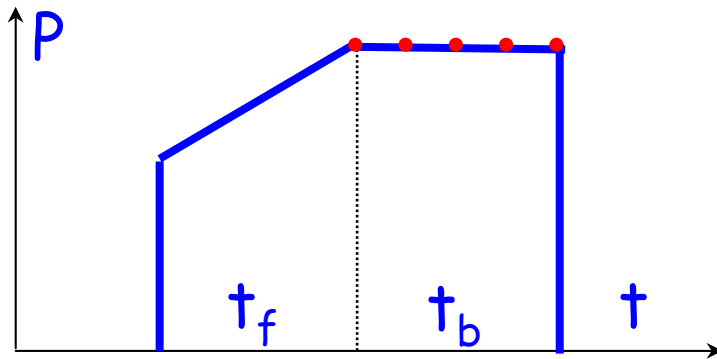

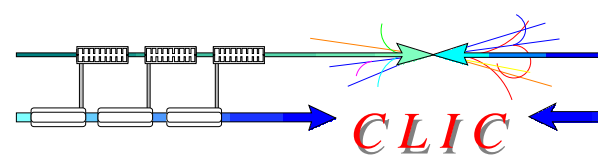

Beam dynamics (BD) constraints based on the simulation of the main linac, BDS and beam-beam collision at the IP:

- $N$  - bunch population depends on  $\langle a \rangle / \lambda$ ,  $\Delta a / \langle a \rangle$ ,  $f$  and  $\langle E_a \rangle$  because of short-range wakes
- $N_s$  - bunch separation depends on the long-range dipole wake and is determined by the condition:

$$W_{t,2} \cdot N / E_a = 10 \text{ V/pC/mm/m} \cdot 4 \times 10^9 / 150 \text{ MV/m}$$

RF breakdown and pulsed surface heating (rf) constraints:

- $\Delta T^{\max}(H_{\text{surf}}^{\max}, t_p) < 56 \text{ K}$
- $E_{\text{surf}}^{\max} < 380 \text{ MV/m}$
- $P_{\text{in}} t_p^{1/3} / C_{\text{in}} = 18 \text{ MW} \cdot \text{ns}^{1/3} / \text{mm} @ \text{X-band}$

# X-band data @ $BDR=10^{-6}$

CLIC

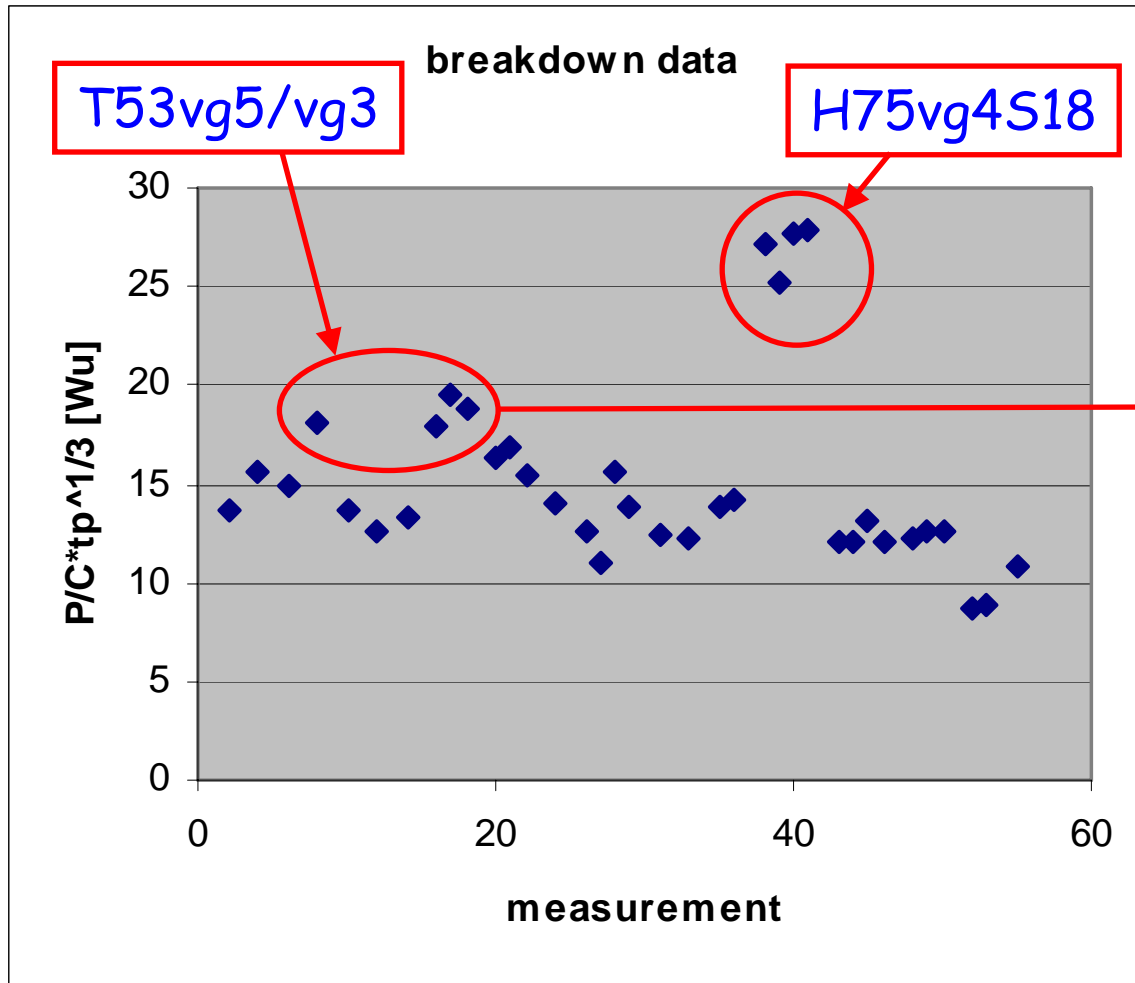

$$P_{in} t_p^{1/3} / C_{in} = 18 Wu$$



# Pulse shape dependences

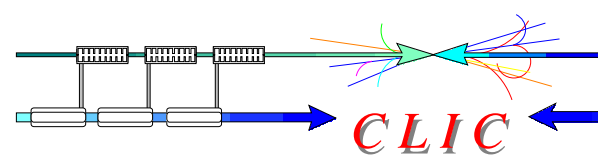

$$P_{in}/P_{in}^{load} = 0.9$$

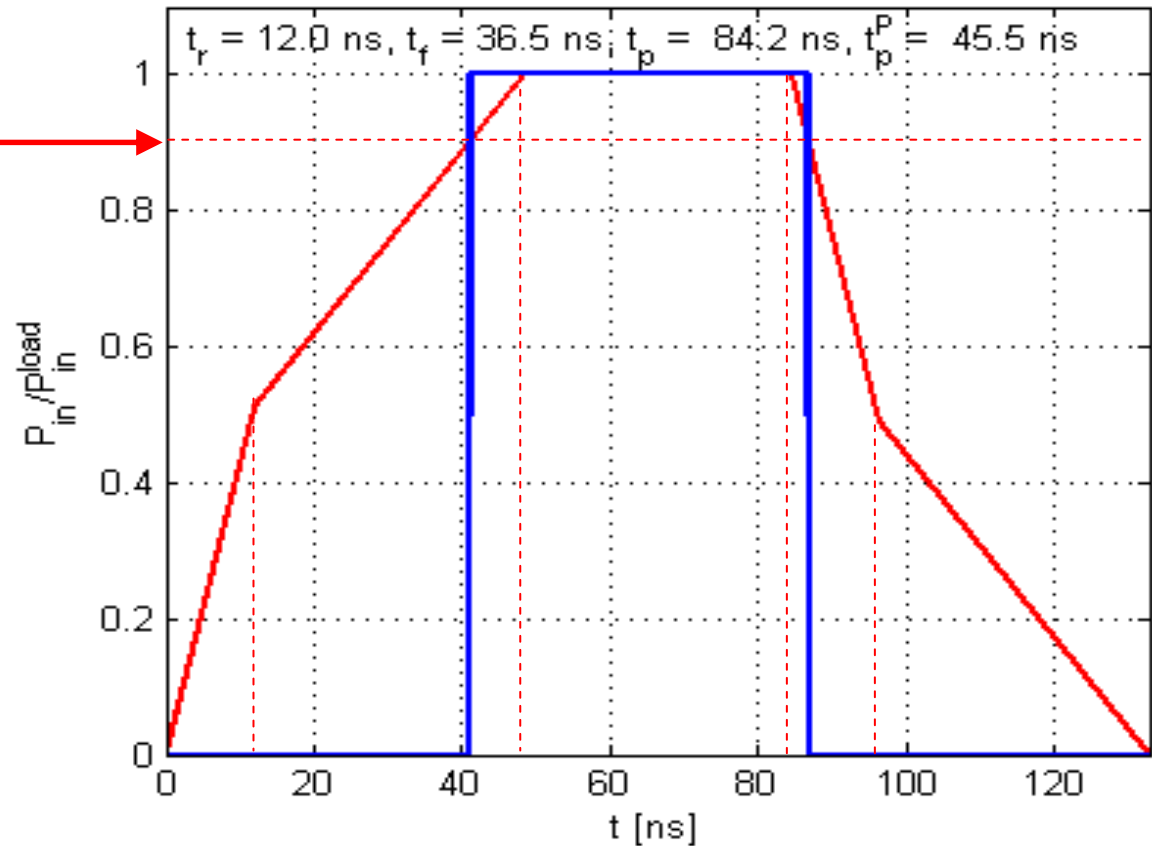

$$\eta: t_p = t_b + t_f + t_r$$

$$\Delta T \sim (t_p^T)^{1/2}: t_p^T = [(t_b + t_f + t_r)^{1/2} - 0.5(t_f + t_r)^{1/2}]^2$$

$$P/C^*(t_p^P)^{1/3}: t_p^P = \text{time when } P_{in}/P_{in}^{load} > 0.9$$

# Effective pulse length for breakdown

CLIC

Rect-pulse => NLC-pulse  
 65 MV/m => 67.5 MV/m

Assuming:  $E_a * t_p^{1/6} = \text{const}$   
 400ns => 320ns

## Structure Performance plots

Averaged over all structures

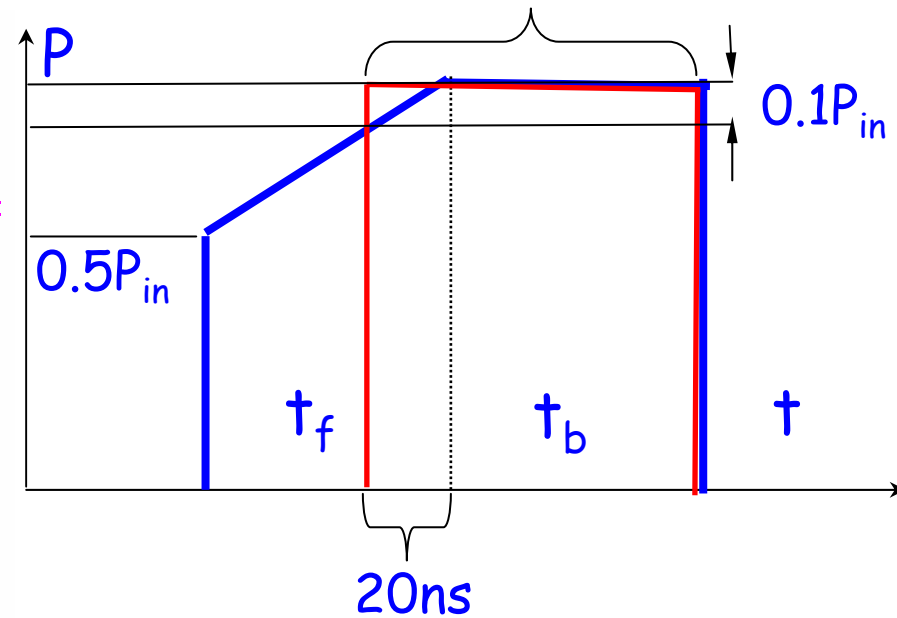
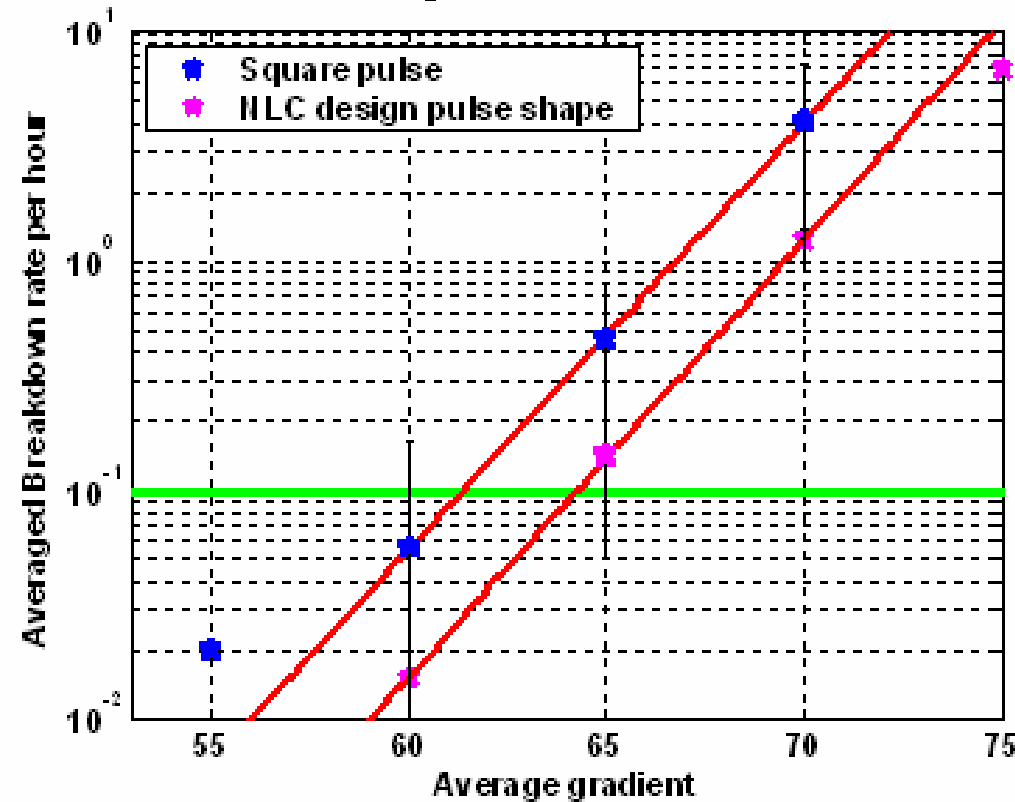

NLC:  $t_f = 100 \text{ ns}$ ;  $t_b = 300 \text{ ns}$

# Frequency scaling of power constraint

CLIC

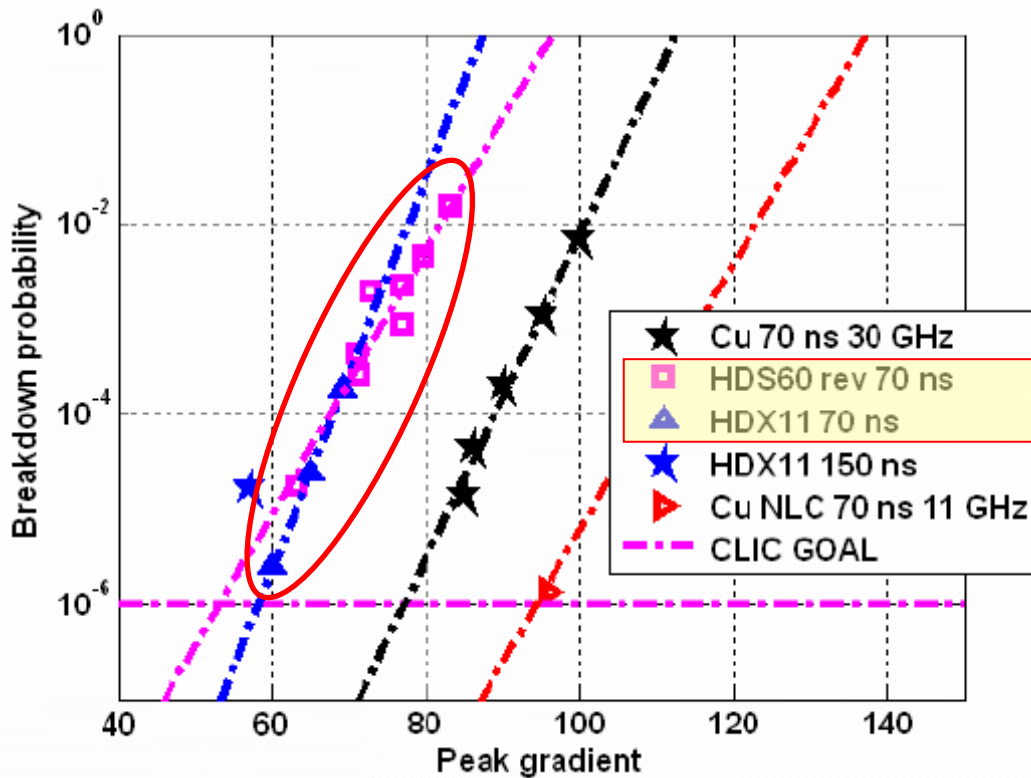

Experimental data at X-band and 30 GHz

Scaled structures

Scaled structures show the same gradient at X-band and at 30 GHz:

$$E_a t_p^{1/6} = \text{const}$$

$$P/C \cdot t_p^{1/3} \cdot f = \text{const}$$



CLIC

Luminosity per linac input power:

$$\frac{L}{P_l} = \frac{L_{bx} N_b f_{rep}}{e E_c N N_b f_{rep} \eta} = \frac{1}{e E_{cm}} \bullet \frac{L_{bx}}{N} \eta$$

Collision energy is constant

Figure of Merit (FoM =  $\eta L_{bx}/N$ )  
in [a.u.] =  $[1e34/bx/m^2 \cdot \% / 1e9]$

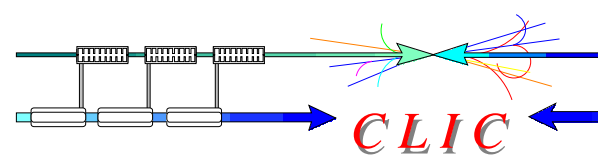

Total cost = Investment cost + Electricity cost for 10 years

$$C_t = C_i + C_e$$

$$C_i = \text{Excel}\{f_r; E_p; t_p; E_a; L_s; f; \Delta\varphi\}$$

Repetition frequency;

Pulse energy;

Pulse length;

Accelerating gradient;

Structure length (couplers included);

Operating frequency;

rf phase advance per cell

$$C_e = (0.032 + 2.4/\text{FoM})$$



CLIC

All structure parameters are variable:

$$\langle E_{\text{acc}} \rangle = 90 - 150 \text{ MV/m,}$$

$$f = 10 - 30 \text{ GHz,}$$

$$\Delta\varphi = 120^\circ, 150^\circ,$$

$$\langle \alpha \rangle / \lambda = 0.09 - 0.21,$$

$$\Delta\alpha / \langle \alpha \rangle = 0.01 - 0.6,$$

$$d_1 / \lambda = 0.025 - 0.1, d_2 > d_1$$

$$L_s = 10 - 100 \text{ mm.}$$

N structures:

7

14

2

24

60

61

4

-----

68.866.560

# Optimizing $L/P$ and $C_+$

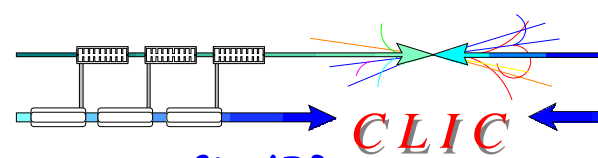

max{ $L/P$ }

$L_{bx}/N^*\eta$  [a.u.]

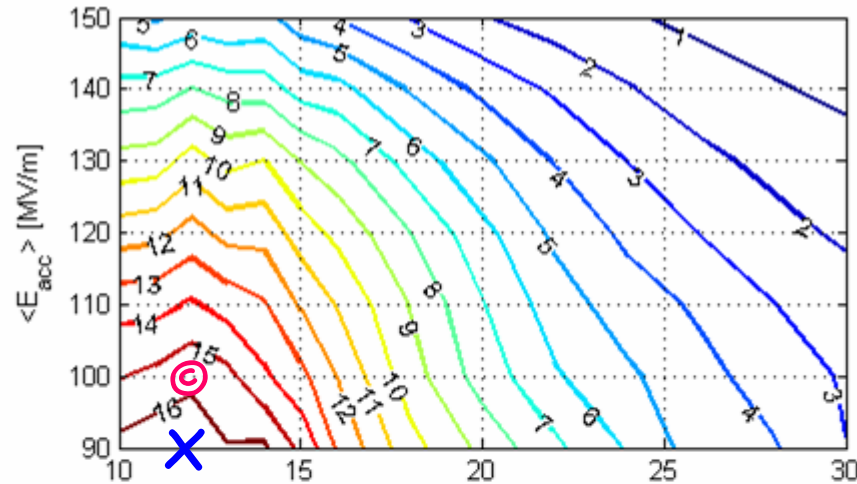

min{ $C_+$ }

$L_{bx}/N^*\eta$  [a.u.]

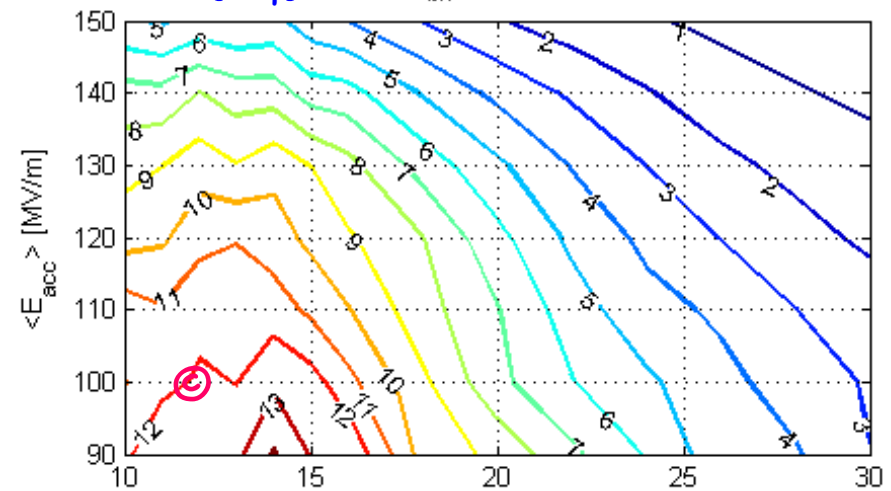

Total Cost [a.u.]

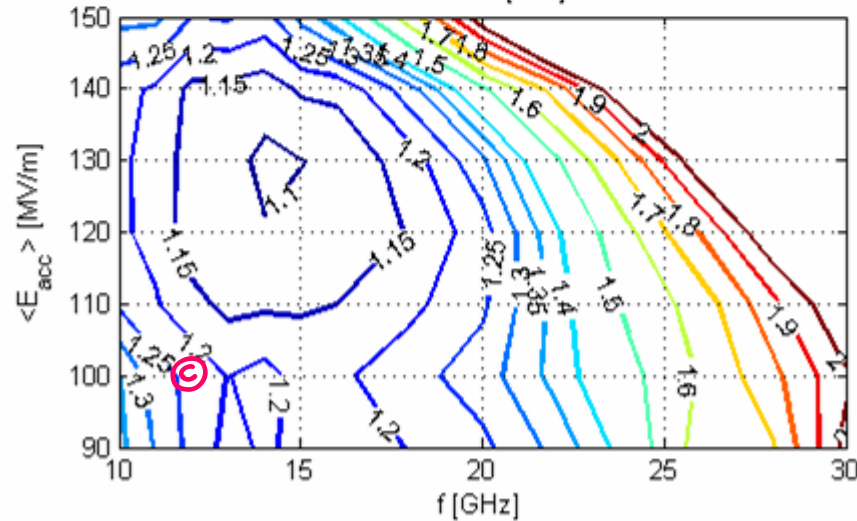

Total Cost [a.u.]

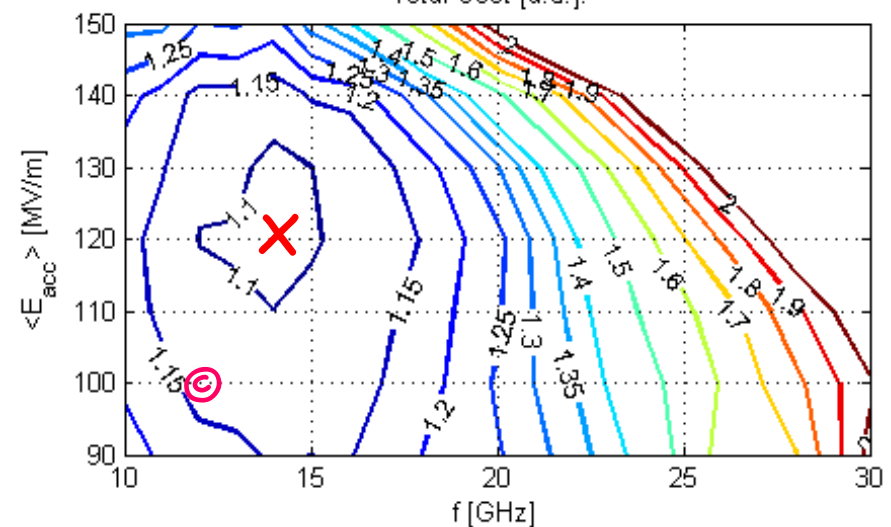

# Total Cost optimization

CLIC

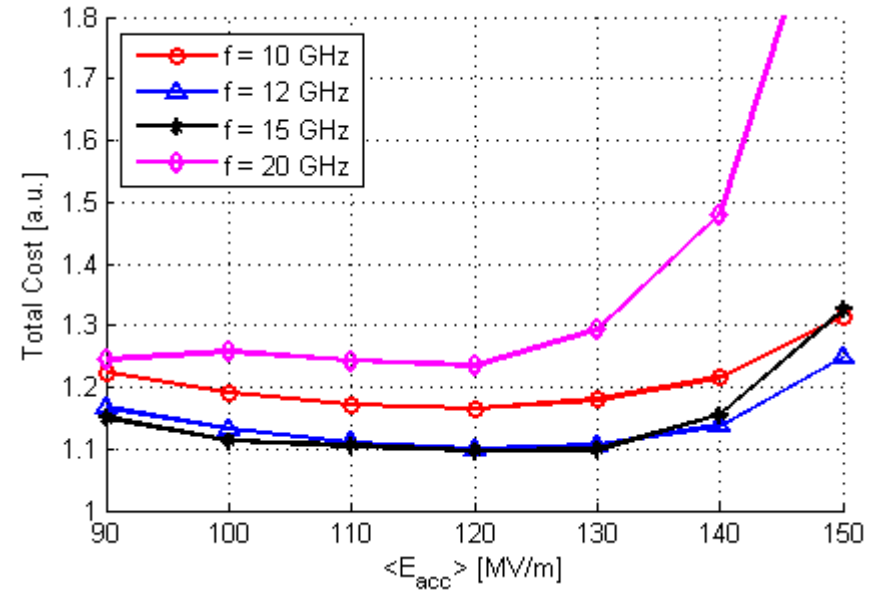
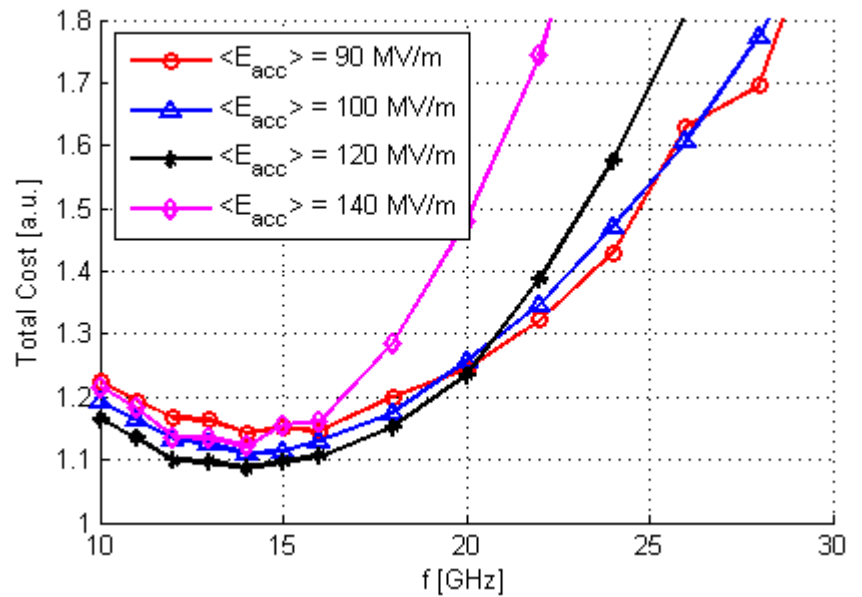
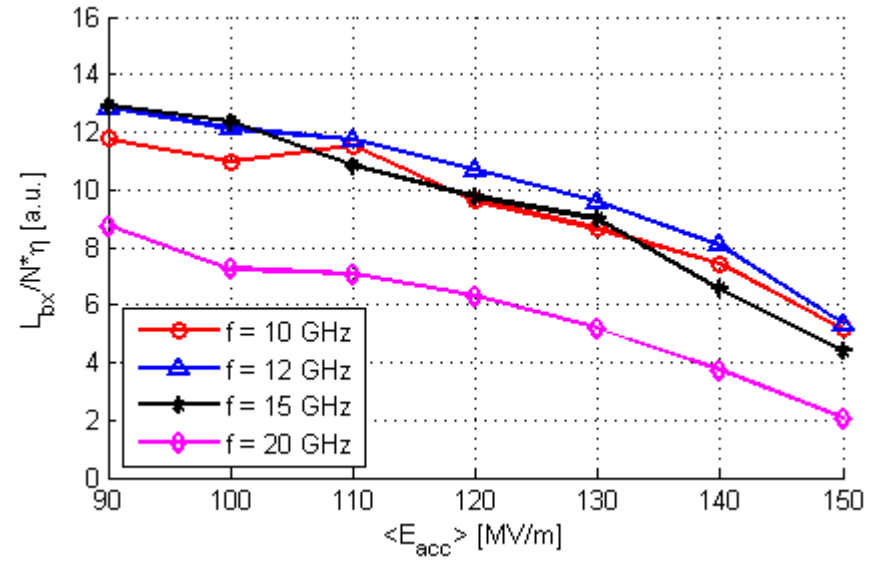
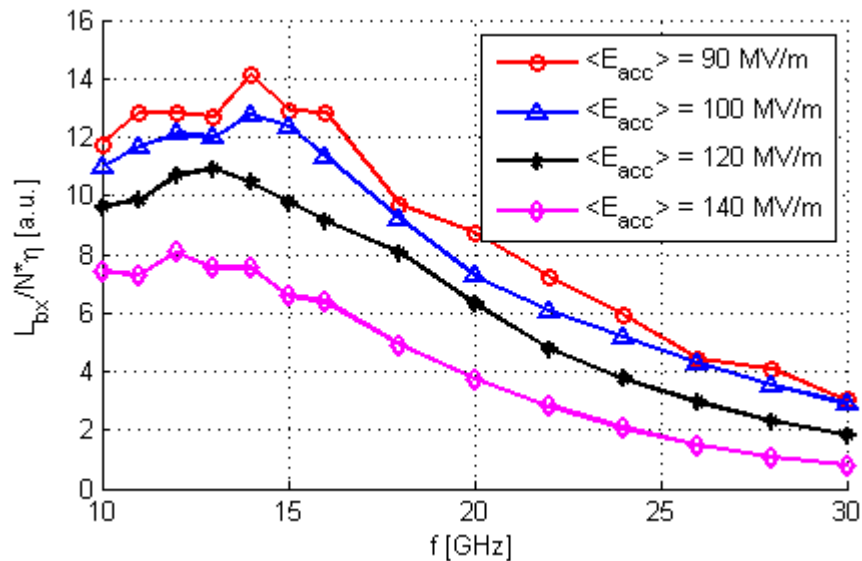



# Parameters of CLIC acc. structure



**CLIC**

Structure	A	B	C
RF phase advance per cell: $\Delta\phi$ [°]	120	120	120
Average iris radius/wavelength: $\langle a \rangle / \lambda$	0.12	0.12	0.12
Input/Output iris radii: $a_{1,2}$ [mm]	3.87, 2.13	3.87, 2.13	3.87, 2.13
Input/Output iris thickness: $d_{1,2}$ [mm]	2.66, 0.83	2.66, 0.83	2.66, 0.83
Group velocity: $v_g^{(1,2)}/c$ [%]	2.39, 0.65	2.39, 0.65	2.39, 0.65
N. of reg. cells, str. length: $N_c, l$ [mm]	24, 229	24, 229	24, 229
Bunch separation: $N_s$ [rf cycles]	7	<u>8</u>	8
Number of bunches in a train: $N_b$	265	311	311
Pulse length, rise time: $\tau_p, \tau_r$ [ns]	244, 30	297, 30	297, 30
Input power: $P_{in}$ [MW]	76	69	64.6
Max. surface field: $E_{surf}^{max}$ [MV/m]	323	309	298
Max. temperature rise: $\Delta T^{max}$ [K]	57	60	56
Efficiency: $\eta$ [%]	31.0	28.8	23.8
Luminosity per bunch X-ing: $L_{bx}$ [m <sup>-2</sup> ]	$2.6 \times 10^{34}$	$2.5 \times 10^{34}$	$1.3 \times 10^{34}$
Bunch population: $N$	$5.8 \times 10^9$	<u><math>5.2 \times 10^9</math></u>	<u><math>4.0 \times 10^9</math></u>
Figure of merit: $\eta L_{bx} / N$ [a.u.]	13.7	13.8	7.7

# Parameters of CLIC main linac

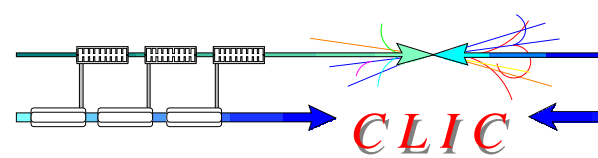

Structure	A	B	C
Luminosity : $L_1 [10^{34} \text{cm}^{-2} \text{s}^{-1}]$	3.3	4.0	2.0
Repetition frequency: $f_{\text{rep}} [\text{Hz}]$	48	50	50
RF input power: $P_l [\text{MW/linac}]$	58.3	69.3	62.1
RF energy per pulse: $P_l / f_{\text{rep}} [\text{kJ/linac}]$	1210	1347	1255
Electricity cost for 10 years: $C_e [\text{a.u.}]$	0.2	0.2	0.36
Investment cost: $C_i [\text{a.u.}]$	0.97	1.00	0.98

# Parameters of CLIC structure (C)

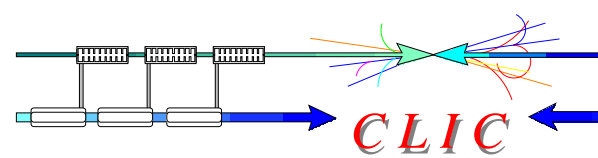

CLIC

Parameters of unloaded (dashed) and loaded (solid) structure

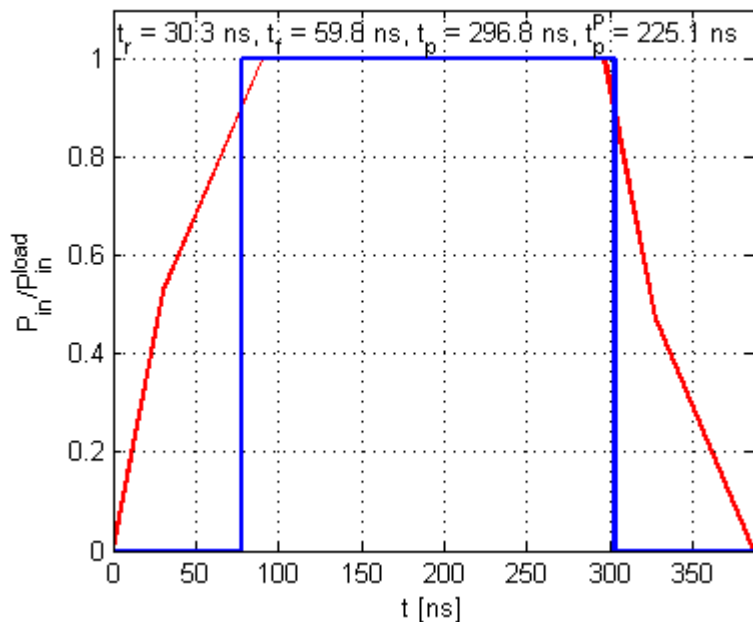
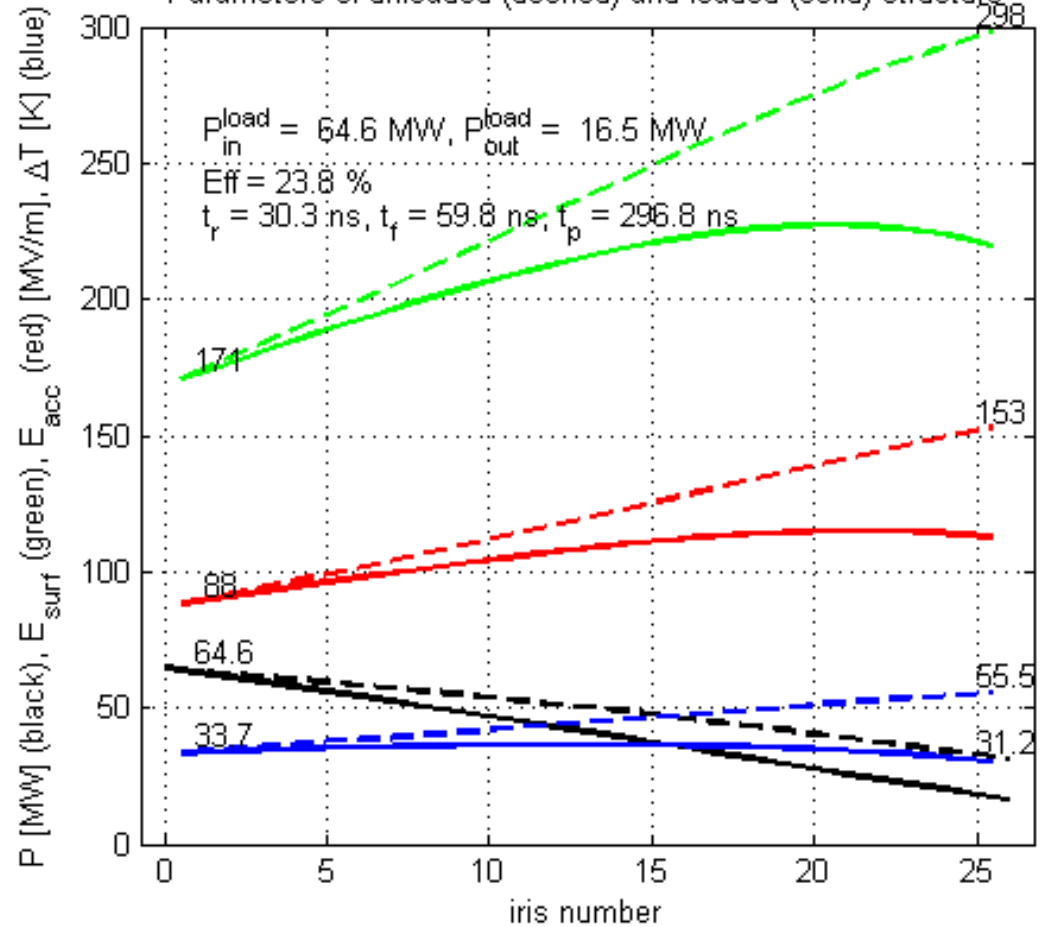

# T53vg3MC structure

CLIC

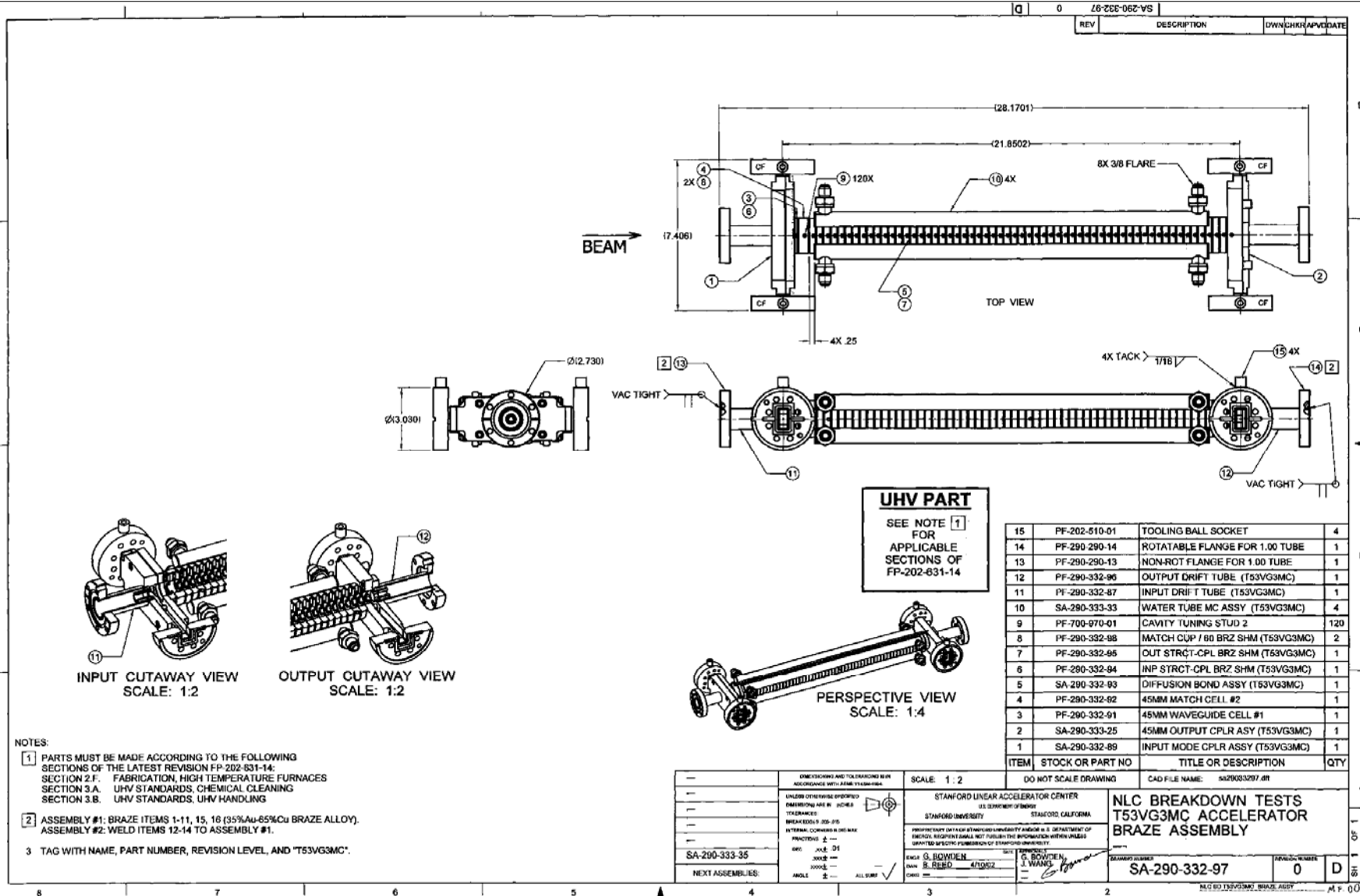

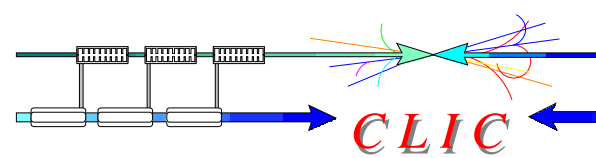

Manufactured: 08.2002

It requires 41 MW for 65 MV/m average gradient

Test results:

$\langle E_a \rangle = 73 \text{ MV/m @ } 400 \text{ ns with BDR} = 0.04 \text{ BD/h} \Rightarrow$

$\langle E_a \rangle = 78 \text{ MV/m @ } 400 \text{ ns with BDR} = 10^{-6} \Rightarrow$

$P_{in} = 60 \text{ MW @ } 400 \text{ ns with BDR} = 10^{-6}$

In the following slides no P/C scaling is involved.

Only  $P_{in} * (t_p^p)^{1/3} = \text{const}$  has been used to scale the maximum pulse length versus input power.

**CLIC**

Name	NDS: first / last	WDS: first/last
a [mm]	3.89 / 3.17	3.89 / 3.17
$Q^{Cu}$	6810 / 6780	5480 / 5400
$v_g/c$ [%]	3.29 / 1.64	2.86 / 1.42
$R'/Q$ [Linac $\Omega/m$ ]	13500 / 15700	11700 / 13550
$E_{surf}^{max}/E_a$	2.0 / 1.9	1.95 / 1.8
$H_{surf}^{max}/E_a$ [mA/V]	2.75 / 2.6	4.6 / 4.5
$P_{in}$ [MW] @ 100MV/m	102 / 44	102 / 44

## Modifications:

1. Introduce damping
2. Change structure length

# T53vg3 performance versus length

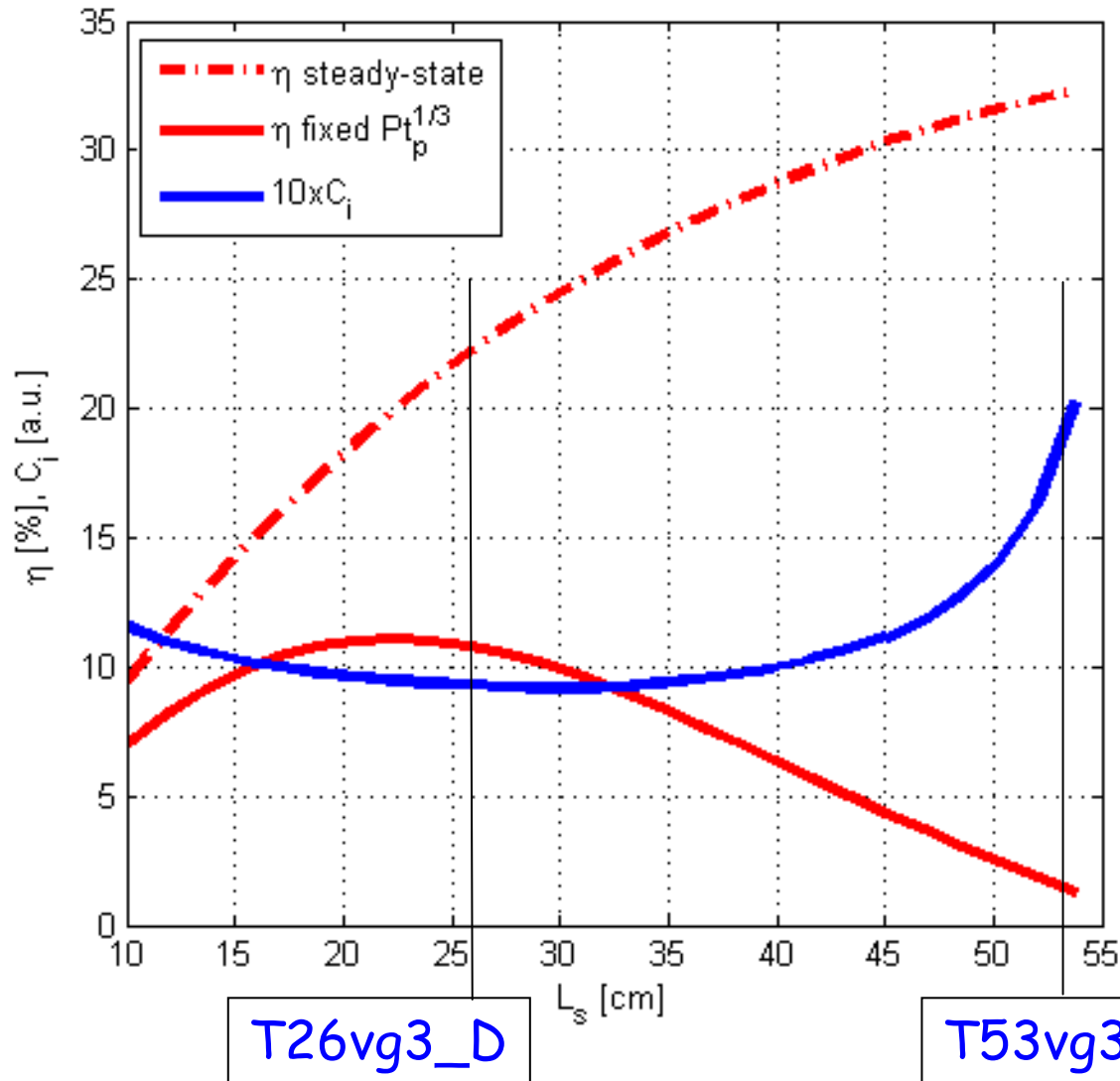
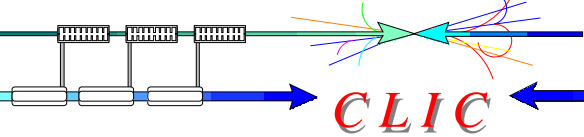

$$N = 4 \times 10^9$$

$$N_s = 8$$

$$P(t_p^P)^{1/3} =$$

$$60 \text{ MW} (400 \text{ ns})^{1/3}$$

# Parameters of CLIC acc. structures



CLIC

Structure	CLIC_C	T26vg3_D
Frequency: $f$ [GHz]	12	11.424
Average iris radius/wavelength: $\langle a \rangle / \lambda$	0.12	0.134
Input/Output iris radii: $a_{1,2}$ [mm]	3.87, 2.13	3.89, 3.17
Input/Output iris thickness: $d_{1,2}$ [mm]	2.66, 0.83	1.66
Group velocity: $v_g^{(1,2)}/c$ [%]	2.39, 0.65	2.86, 1.42
N. of reg. cells, str. length: $N_c, l$ [mm]	24, 229	28, 270
Bunch separation: $N_s$ [rf cycles]	8	8
Number of bunches in a train: $N_b$	311	66
Pulse length, rise time: $\tau_p, \tau_r$ [ns]	297, 30	102, 12
Input power: $P_{in}$ [MW]	64.6	111
Max. surface field: $E_{surf}^{max}$ [MV/m]	298	216
Max. temperature rise: $\Delta T^{max}$ [K]	56	26
Efficiency: $\eta$ [%]	23.8	10.3
Luminosity per bunch X-ing: $L_{b \times}$ [m <sup>-2</sup> ]	$1.3 \times 10^{34}$	$1.3 \times 10^{34}$
Bunch population: $N$	$4.0 \times 10^9$	$4.0 \times 10^9$
Figure of merit: $\eta L_{b \times} / N$ [a.u.]	7.7	3.3



# Parameters of CLIC main linac

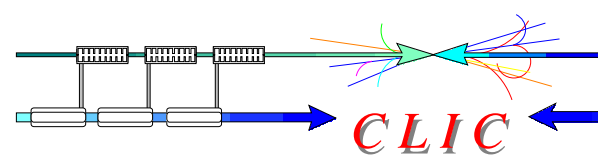

Structure	CLIC_C	T26vg3_D
Luminosity : $L_1 [10^{34} \text{cm}^{-2} \text{s}^{-1}]$	2.0	2.0
Repetition frequency: $f_{\text{rep}} [\text{Hz}]$	50	233
RF input power: $P_l [\text{MW/linac}]$	62.1	143
RF energy per pulse: $P_l / f_{\text{rep}} [\text{kJ/linac}]$	1255	614
Electricity cost for 10 years: $C_e [\text{a.u.}]$	0.36	0.74
Investment cost: $C_i [\text{a.u.}]$	0.98	0.93

# Parameters of T26vg3\_D

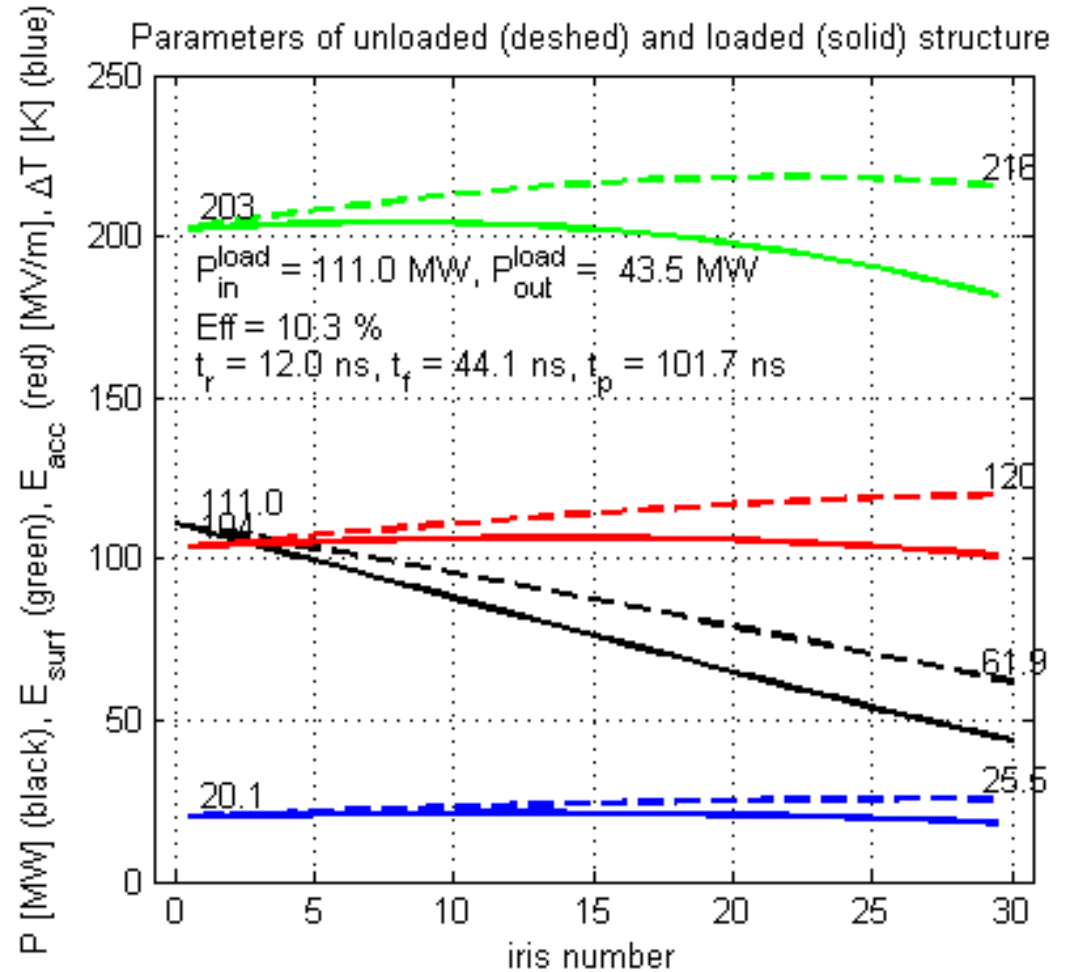
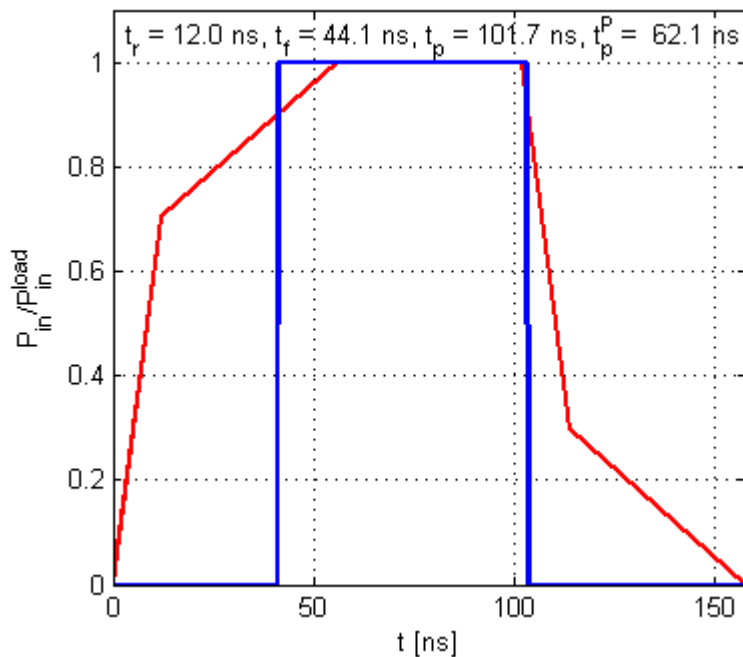
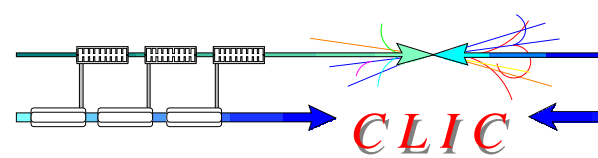

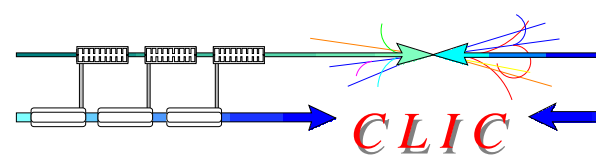

- Optimization of CLIC frequency and gradient has been done, based on the cost model and taking into account new experimental data at 30 GHz and NLCTA measurement results at X-band
- This (together with some other considerations) resulted in major change of CLIC parameters (from 150MV/m@30GHz to 100MV/m@12GHz)
- RF design of X-band CLIC accelerating structure has been done based on the results of optimization

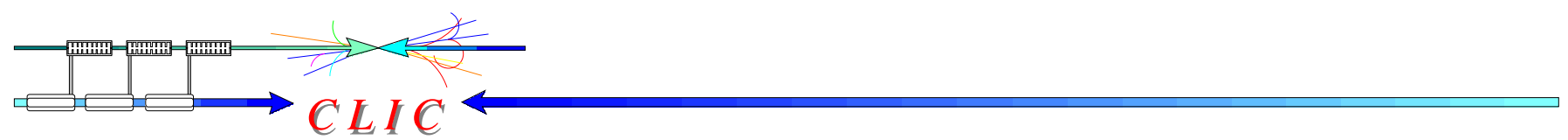

# $L_{bx}/N$ for different gradients

CLIC

$L_1/N$  [ $10^{24}/bx/m^2$ ] for  $\langle E_{acc} \rangle = 150$  MV/m,  $\sigma_x = 60$  nm

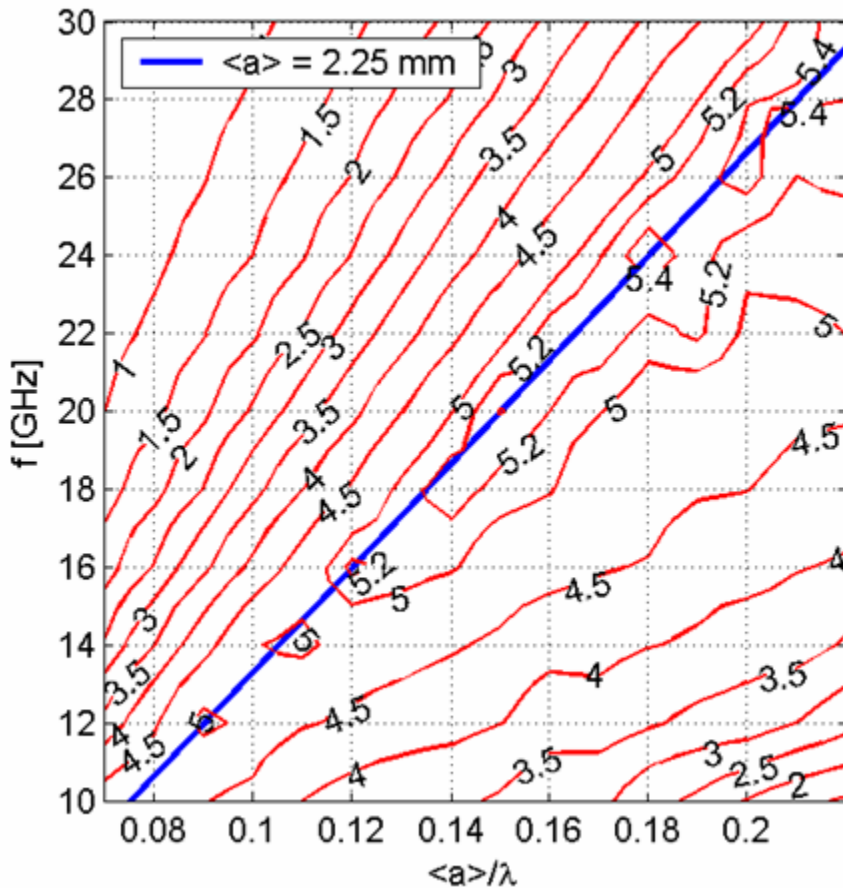

$L_1/N$  [ $10^{24}/bx/m^2$ ] for  $\langle E_{acc} \rangle = 100$  MV/m,  $\sigma_x = 60$  nm

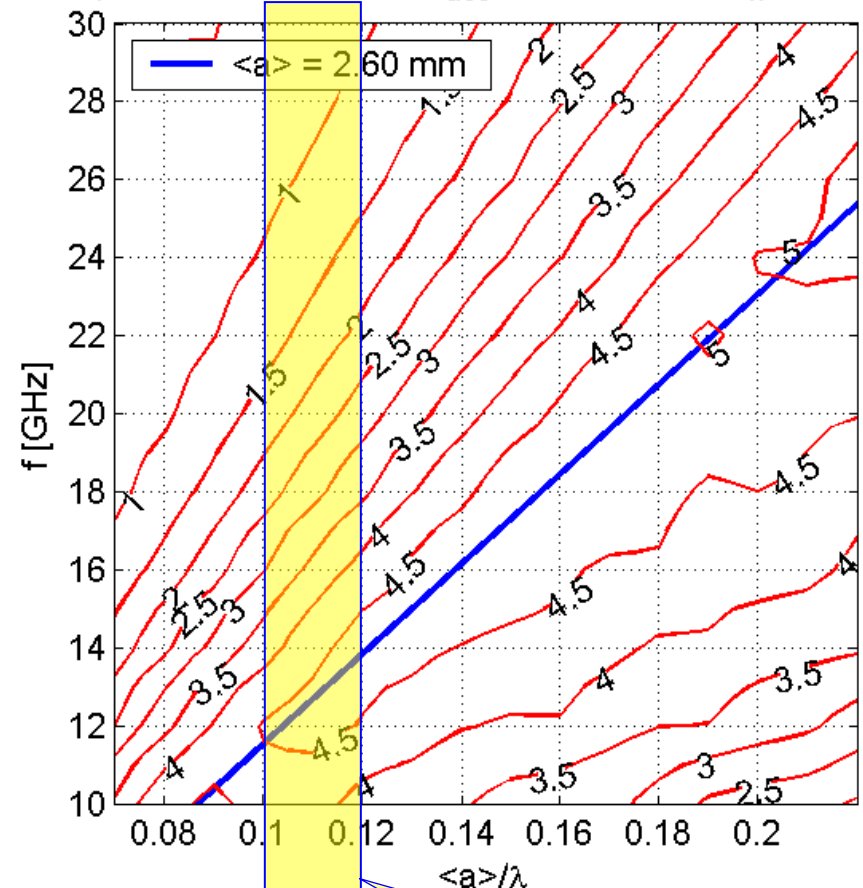

Why X-band? A simplistic explanation:  
Crossing gives the optimum frequency

Determined by  
RF constraints

# Parameters of CLIC acc. structures



CLIC

Structure	CLIC_C	T23vg3_D	T53vg3_D
Frequency: $f$ [GHz]	12	11.424	11.424
Average iris radius/wavelength: $\langle a \rangle / \lambda$	0.12	0.134	0.134
Input/Output iris radii: $a_{1,2}$ [mm]	3.87, 2.13	3.89, 3.17	3.89, 3.17
Input/Output iris thickness: $d_{1,2}$ [mm]	2.66, 0.83	1.66	1.66
Group velocity: $v_g^{(1,2)}/c$ [%]	2.39, 0.65	2.86, 1.42	2.86, 1.42
N. of reg. cells, str. length: $N_c, l$ [mm]	24, 229	23, 232	58, 530
Bunch separation: $N_s$ [rf cycles]	8	8	8
Number of bunches in a train: $N_b$	311	82	6
Pulse length, rise time: $\tau_p, \tau_r$ [ns]	297, 30	105, 12	103, 12
Input power: $P_{in}$ [MW]	64.6	106	155
Max. surface field: $E_{surf}^{max}$ [MV/m]	298	222	240
Max. temperature rise: $\Delta T^{max}$ [K]	56	29	23
Efficiency: $\eta$ [%]	23.8	10.9	1.3
Luminosity per bunch X-ing: $L_{bx}$ [m <sup>-2</sup> ]	$1.3 \times 10^{34}$	$1.3 \times 10^{34}$	$1.3 \times 10^{34}$
Bunch population: $N$	$4.0 \times 10^9$	$4.0 \times 10^9$	$4.0 \times 10^9$
Figure of merit: $\eta L_{bx} / N$ [a.u.]	7.7	3.6	0.4

# Parameters of CLIC main linac

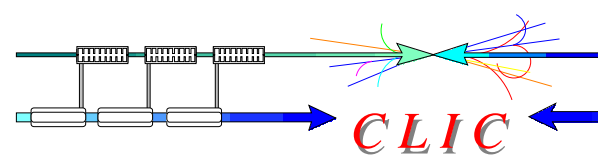

Structure	CLIC_C	T23vg3_D	T53vg3_D
Luminosity : $L_1$ [ $10^{34}\text{cm}^{-2}\text{s}^{-1}$ ]	2.0	2.0	2.0
Repetition frequency: $f_{\text{rep}}$ [Hz]	50	188	2564
RF input power: $P_l$ [MW/linac]	62.1	136	1145
RF energy per pulse: $P_l/f_{\text{rep}}$ [kJ/linac]	1255	724	447
Electricity cost for 10 years: $C_e$ [a.u.]	0.36	0.71	5.7
Investment cost: $C_i$ [a.u.]	0.98	0.95	2.0

# Parameters of T23vg3\_D

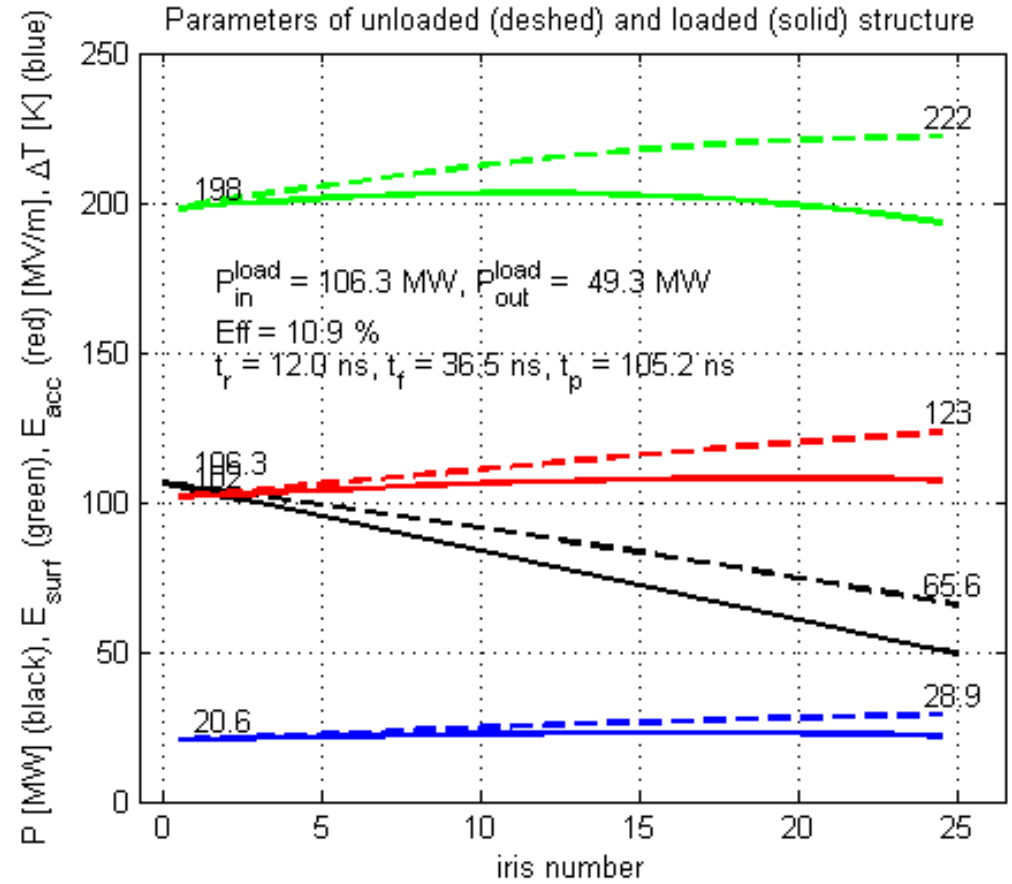
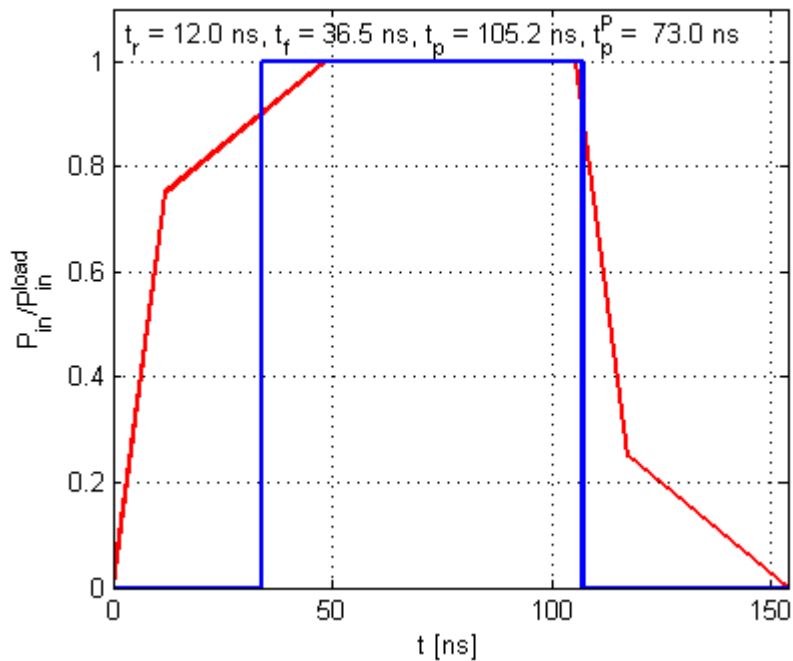
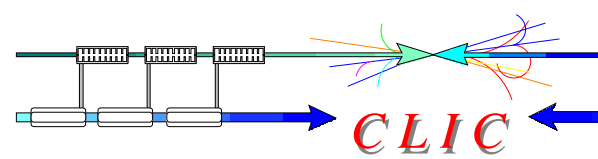



# Parameters of T53vg3\_D

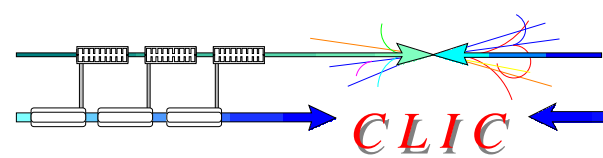

**CLIC**

