



Istituto Nazionale di Fisica Nucleare
SEZIONE DI FIRENZE

Development of a High-Resolution, High-Dynamic-Range Charge Detector for Ion Beam Monitoring

Lorenzo Pacini

INFN, Florence, Italy

lorenzo.pacini@fi.infn.it

The research group background.

- Our research group is involved in several space experiments for the direct measurement of cosmic-ray, e.g. HERD.
- HERD is a calorimeter for the measurements of protons and nuclei up to 10^{15} eV.

Tentative HERD design

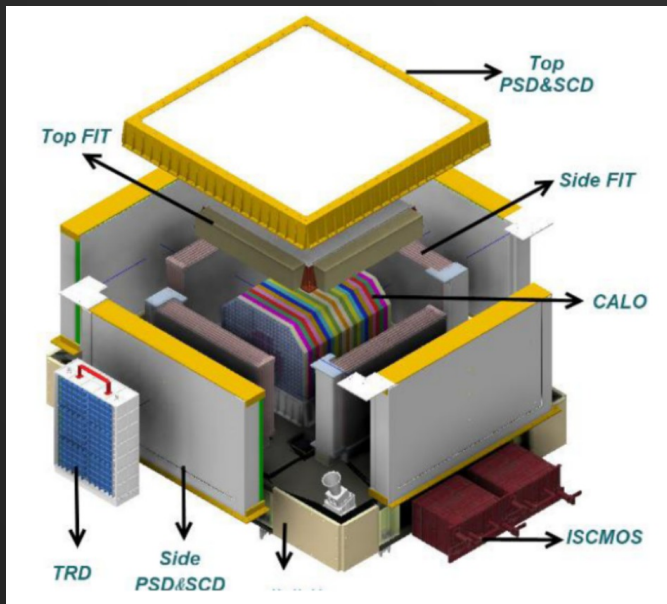

Expected proton flux measured by HERD

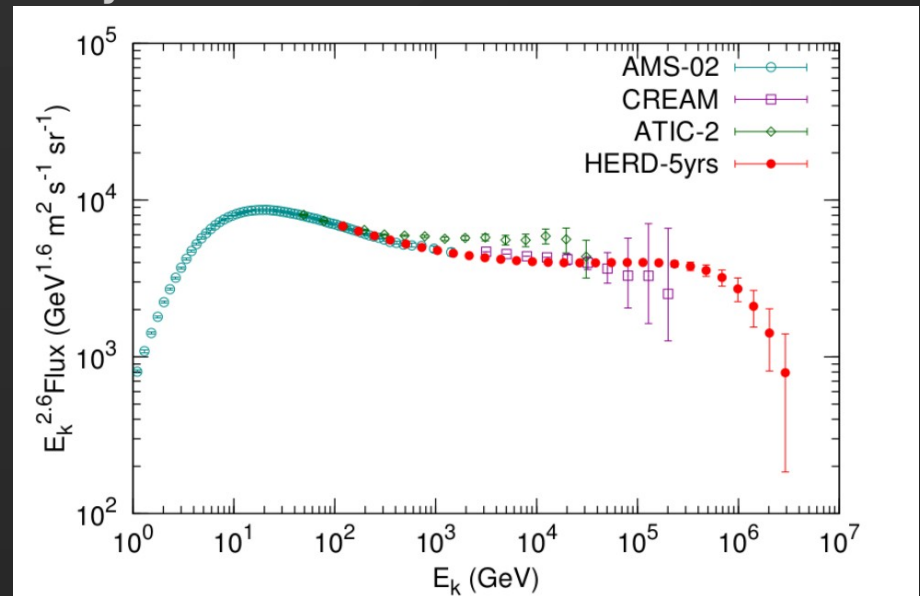

A ion beam monitor for HERD

- 2022 HERD beam test with ions at SPS, the collaboration needed:
 - a beam monitor to quickly check the composition of the beam,
 - a reliable and independent charge measurement.
- The detector has been designed with the following features:
 - simple and easy to mount (dismount) due to HERD mechanical restriction,
 - quick on-line analysis results,
 - thin in order to avoid large number of fragmented nuclei in the detector,
 - high dynamic range to measure charge from 1 to ~ 80 (Pb).
- A further difficulty was the short time available before the test.

Design of the first prototype.

- Due to the time restriction, well known components have been employed.
- The prototype were made of 6 blind photo-diodes: VTH2090 (see slide 5).
- This sensor was already characterized in details for the CaloCube R&D project (“O. Adriani et al 2019 JINST 14 P11004”)
- To match the required high dynamic range, the read-out electronics of the calorimeter PD-system was used (see silde 6):
 - It is based on HiDRA front-end chip.
- A very simple mechanical structure was also designed.

Design of the first prototype

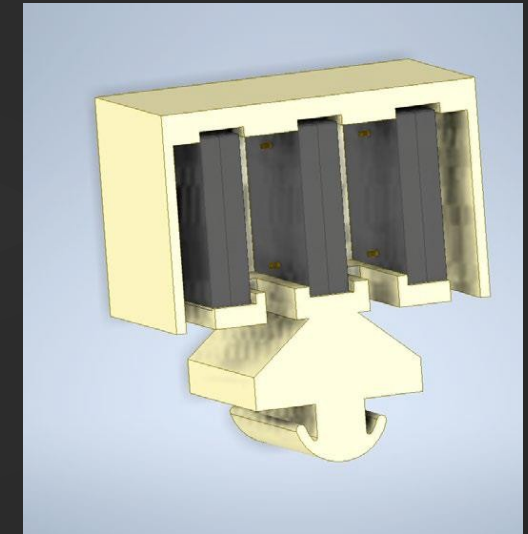

The sensor: VTH2090

- The VTH2090 is a large area PD (9.2 x 9.2 mm²).
- Accurate information of electro-optical characteristics is presents but detailed information regarding the diode thickness is unavailable
- We measured the PD capacitance.

VTH2090

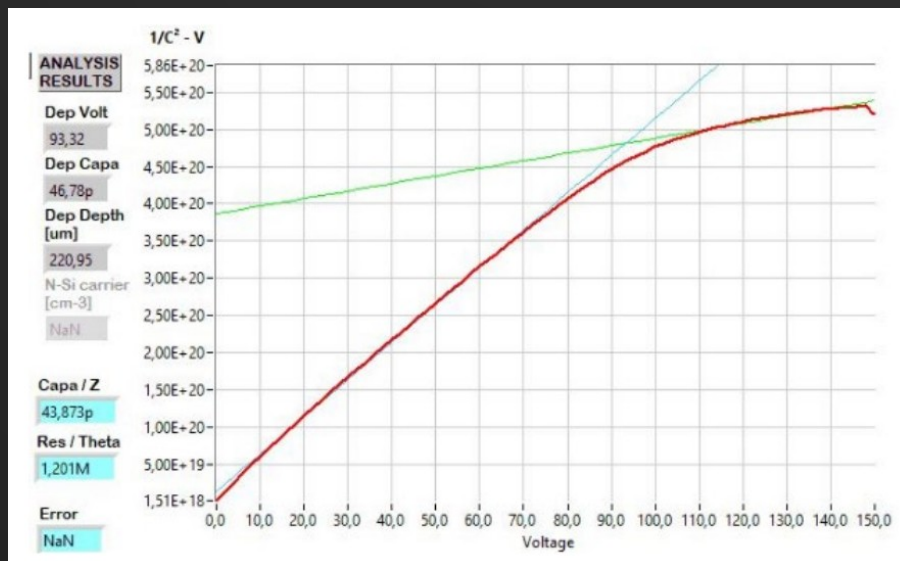
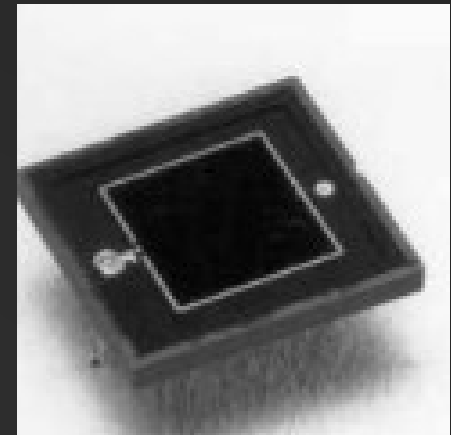

The obtained depletion depth is ~ 220 um

The electronics: HiDRA chip

- Custom chip HiDRA, designed by INFN-Trieste (Italy), v2.
- Double gain CSA with automatic-gain selection circuitry.
 - High dynamic range ($\sim 5 \cdot 10^5$)
 - Low power consumption ~ 3.5 mW/chan.
 - Low noise: ENC $\sim 2500e$
 - 16 input channels.
 - Self-trigger system.
- See: “O. Adriani et al 2022 JINST 17 P09002”

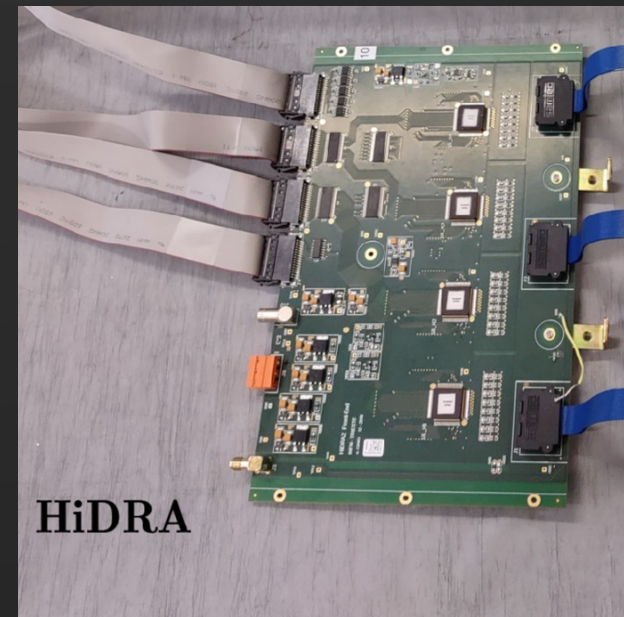
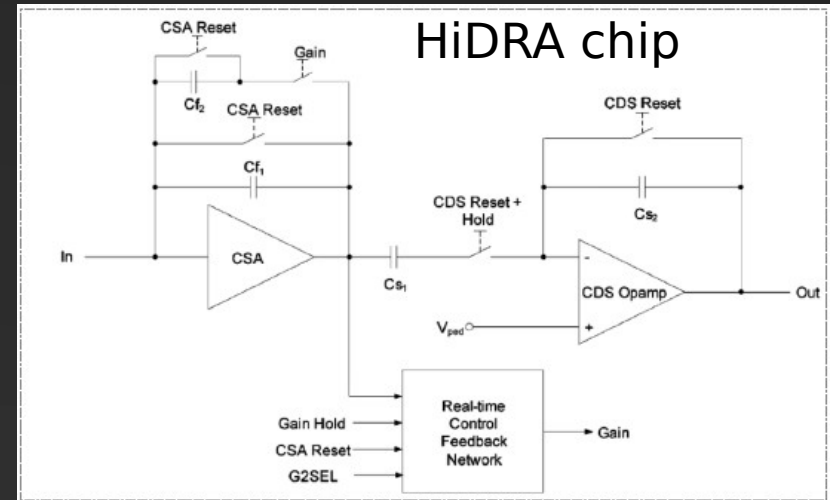

The first test: 2022 HERD.

- We employed the first prototype in 2022 for the HERD with ion @ SPS.
- The main purpose was nuclei identification to check the non-linearity of the LYSO scintillator (HERD CALO active material).
- We implemented a simple analysis strategy:
 - Convert ADC \rightarrow MIP
 - Convert MIP \rightarrow Z
 - Evaluate if ADC signal $>$ threshold.
 - Selection: number of diodes above noise threshold $>$ 3.

A picture of the prototype

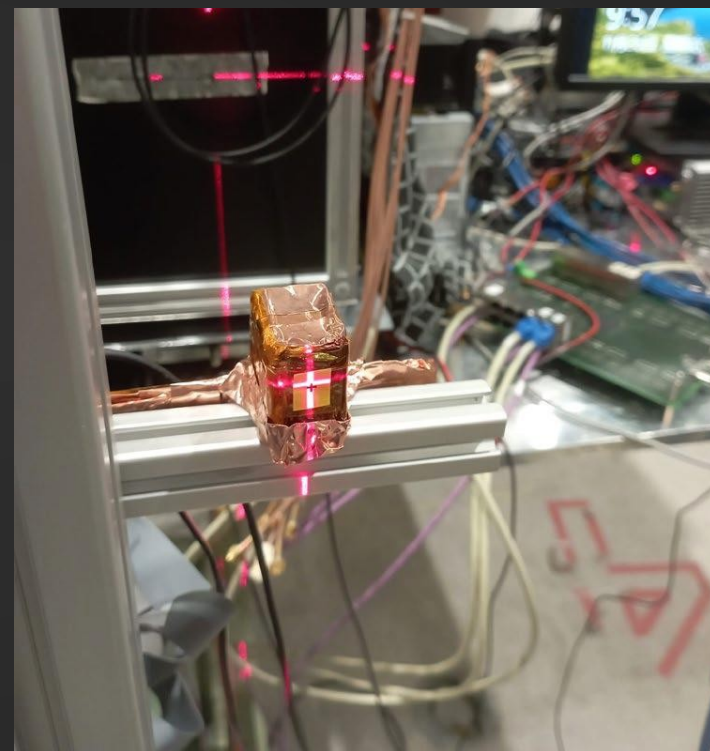

2022 beam test result: ion peaks

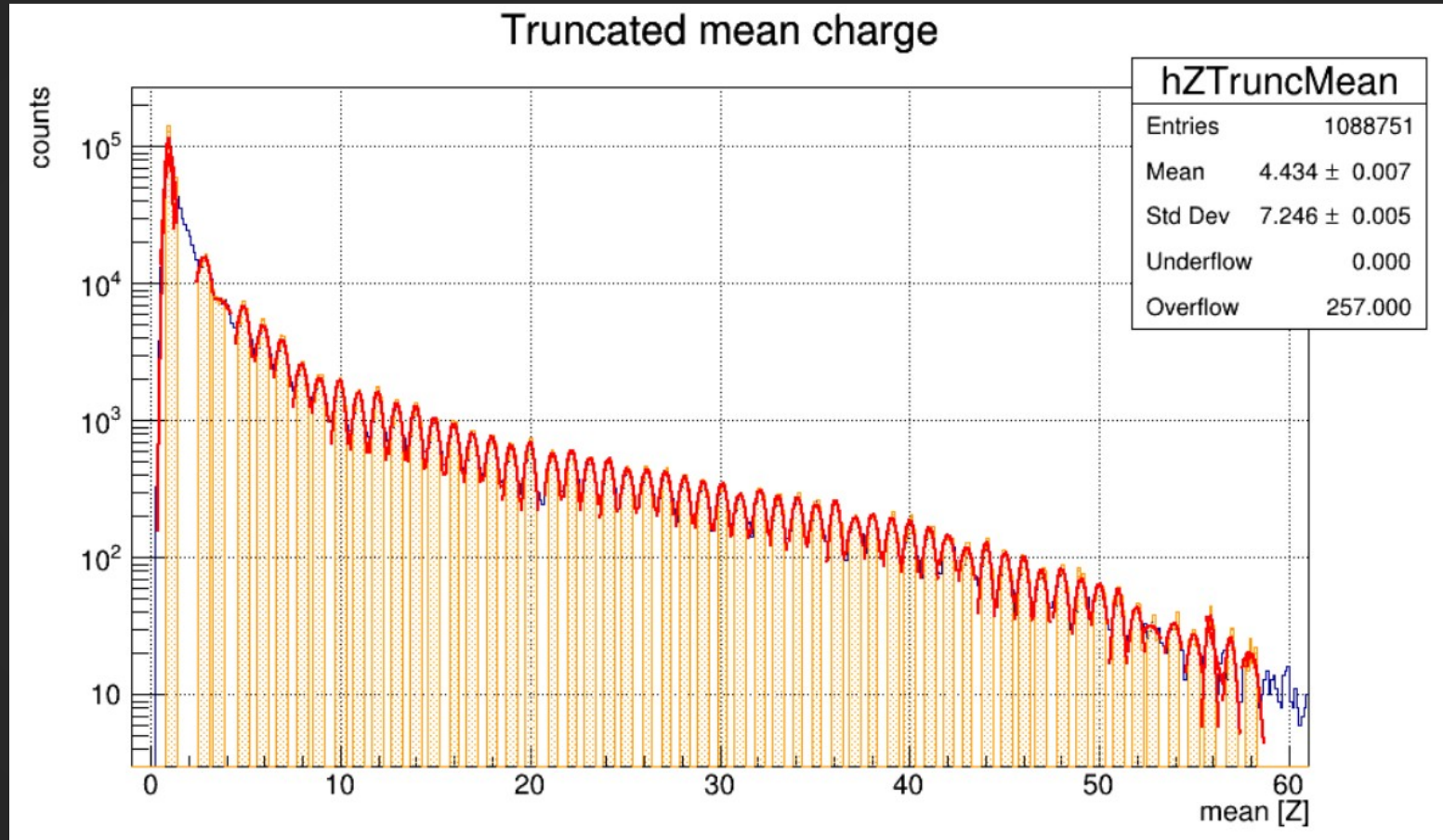

- First prototype: charge peaks (fitted with Gaussian distributions) up to $Z \sim 60$.

2022: resolution and linearity

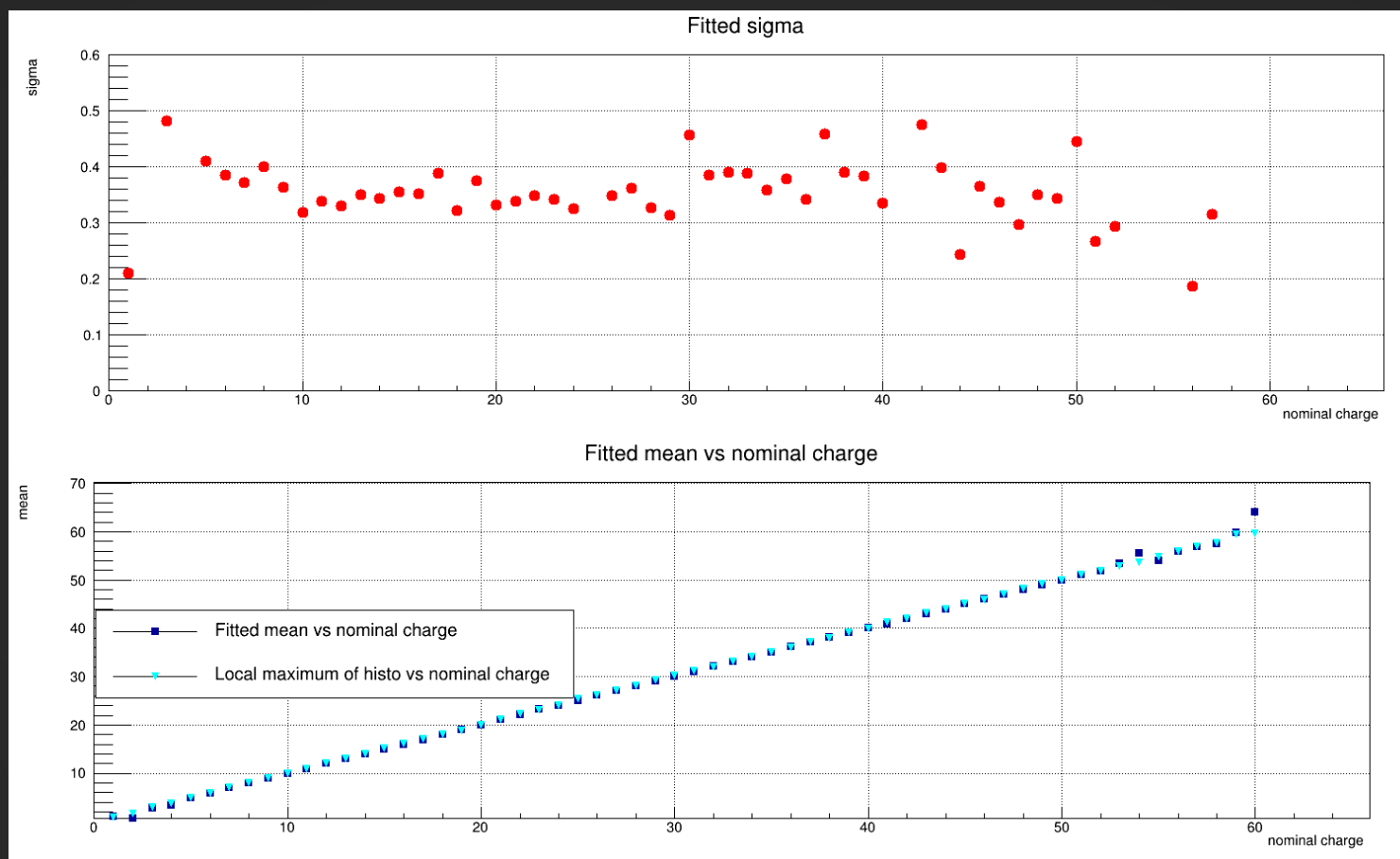

- The charge resolution is $\sim < 0.4$ charge unit and almost flat in the entire range
- Linearity response is also achieved.

Second and third test.

- 2023 HERD: nuclei tag used to check the performance of large scale prototype with nuclei.
- 2023 AMS-02: first test outside the HERD collaboration. Data are employed for independent charge tag and charge reconstruction efficiency evaluation.
- Improved analysis strategy.
 - Evaluate the number of consistent PDs with the one considered.
 - Selection: maximum number of consistent diodes = 6,
- Improved PD bias: from 40 V to 100 V to maximize the depleted region.

CNO nuclei peaks

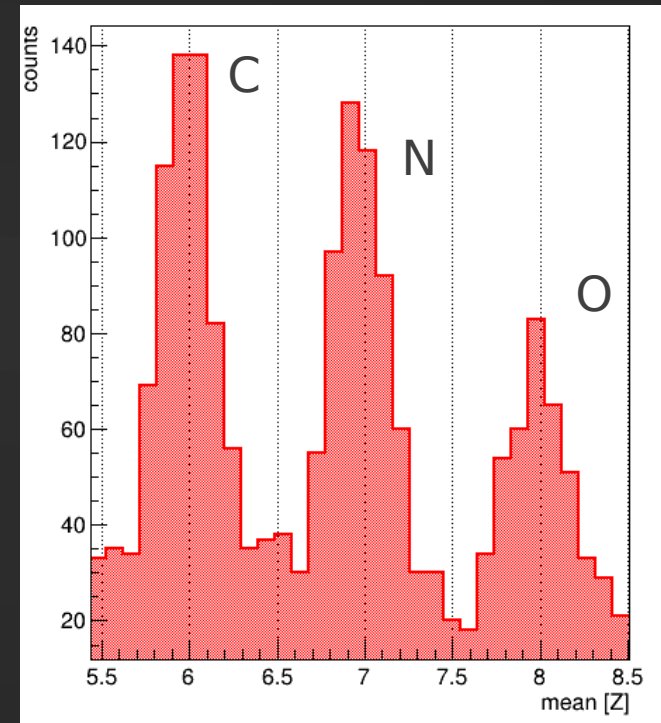

2023 beam test results: ion peaks

- Two different SPS ion beams:

- $A/Z \sim 2.2$
- $A/Z \sim 2$

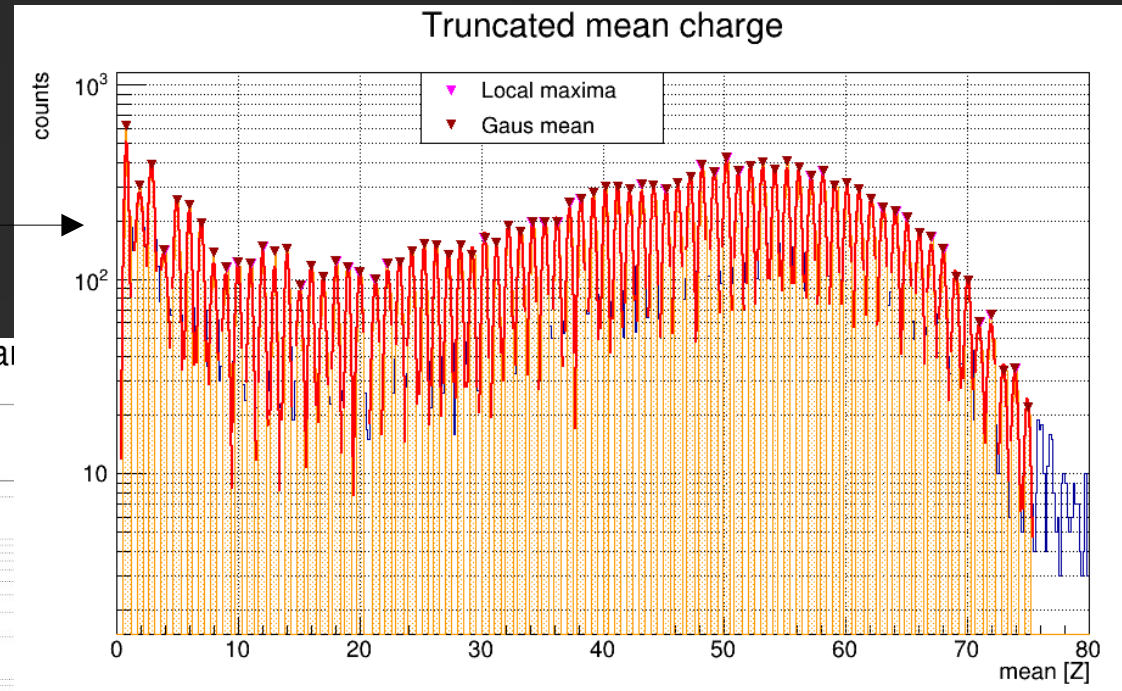
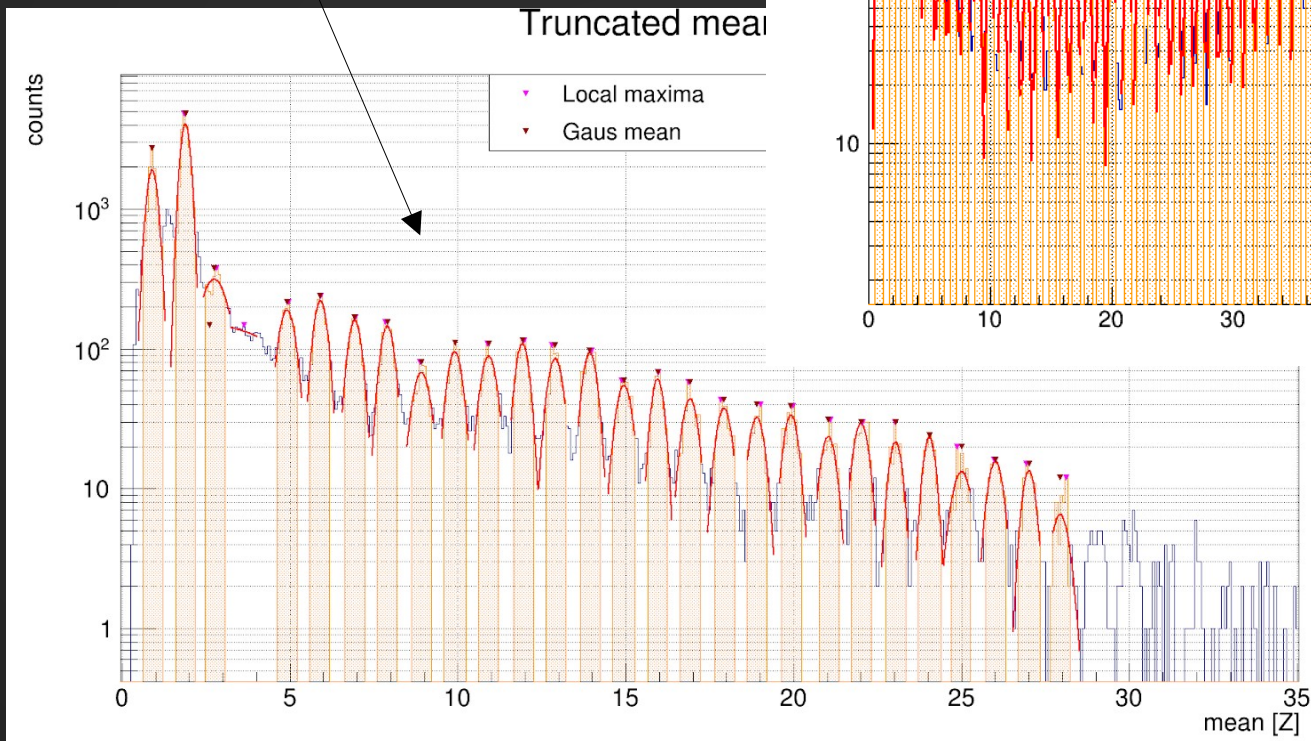

2023: resolution and linearity

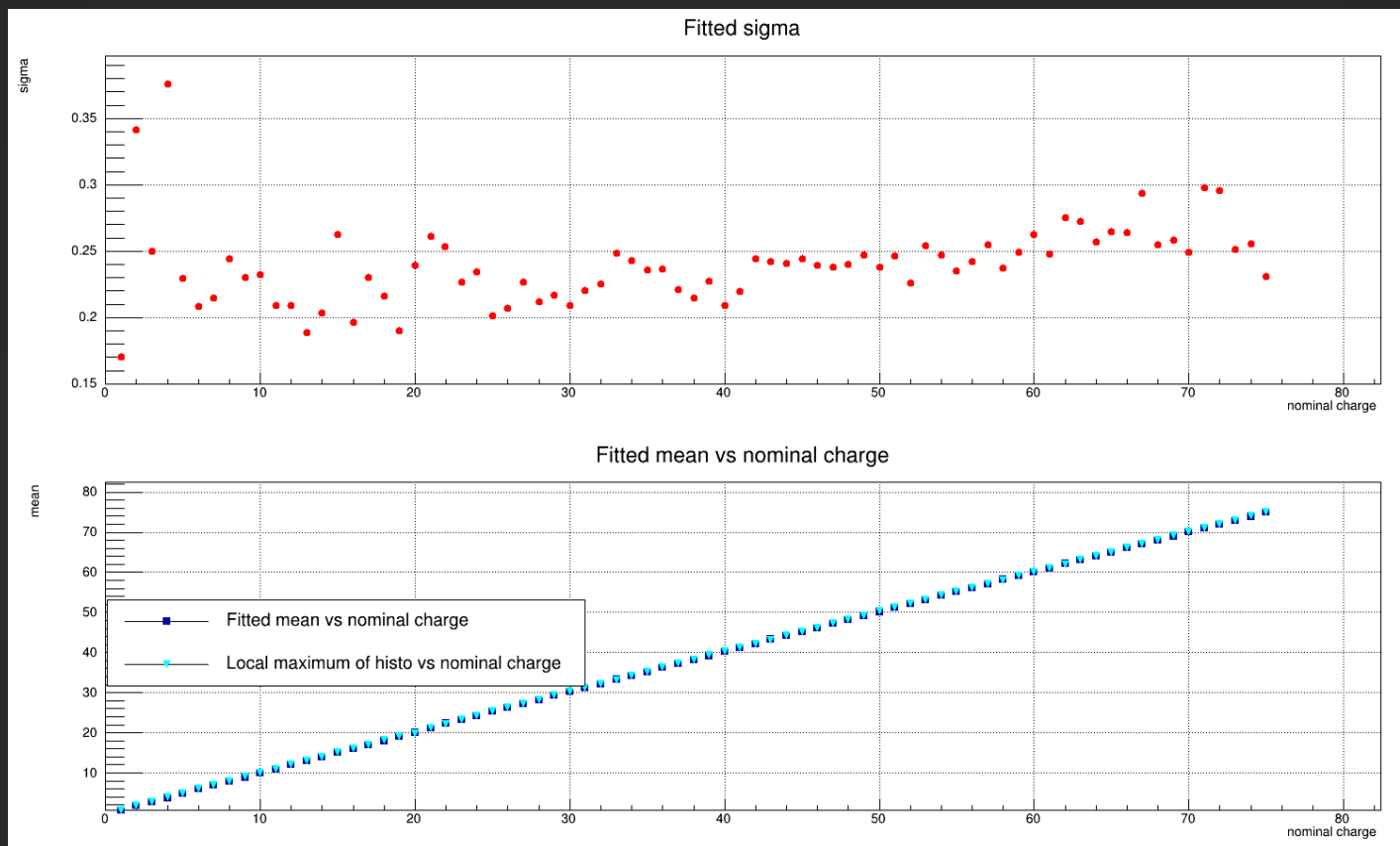

- The charge resolution is $\sim < 0.3$ charge unit and just slightly increase with Z .
- The fitting procedure could be improved especially for $Z < 5$.

A new project: BeER.

- Thanks to:
 - good results of 2022 and 2023 beam tests,
 - good feedback received from several SPS ion beam users,
- we have just decided to start a project dedicated to this detector named “Beam-monitor with Extreme Range” (BeER). 
- We are investigating possible applications of BeER:
 - on-line monitor of high energy ion beams (e.g. SPS),
 - event-by-event charge tagging system
 - on-line monitor of high multiplicity beams (e.g. LNF-BTF).
 - application in experiments, (e.g. cosmic rays...)
- We are completely open to suggestions about BeER application and future design.

Next steps: short-term (2024).

- VTH2090 is discontinued:
 - new sensor is VTH2021.
- Enlarge the active area of the detector by adding more PDs.
 - 6 layers, 3x3 PDs
- Adjust the mechanics for the new design, add motorized sliders.
- Adjust the electronics to read-out more channels with HiDRA 2 chip.
- Test the new prototype at:
 - LNF-BTF (Frascati) (June)
 - SPS (CERN) (TBD)

VTH2021: 10x10 mm²

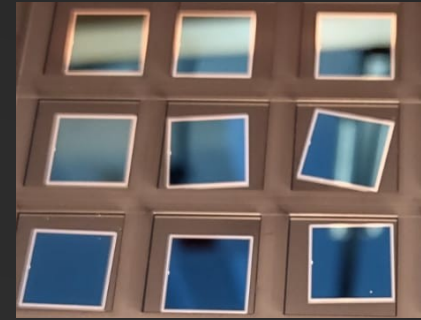

New prototype design

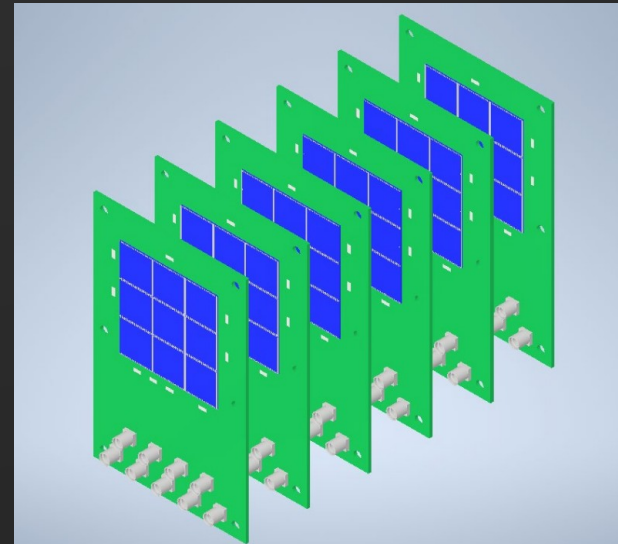

Conclusion

- Starting from the HERD requirements, a high-dynamic range charge detector was developed (BeER)
- The main features are:
 - good S/N for MIP (proton peak) $> \sim 4$,
 - high saturation level ($Z > 100$),
 - easy to use and simple analysis procedure (quick look),
 - the instrument is not expensive (e.g. ~ 15 € for each PD).
- First prototypes have been tested with SPS ion beam and very good performance has been confirmed:
 - we are going to submit a paper about BeER.
- We are collecting suggestions on possible uses of BeER:
 - long-term plan will be defined according to the feedback of the scientific community.

Thank you for your attention

